

SOFAS VOLUME ONE  
2022

**Poliform**



**Poliform**

Poliform presenta la collezione di imbottiti. Divani e poltrone che arredano i living più esclusivi e tutti gli ambienti della casa dove ci siano spazi da dedicare al comfort e al relax. Divani fissi o componibili pensati per diventare protagonisti della zona giorno e poltrone dai volumi avvolgenti. Lo stile è quello di Poliform – tra design eccellente, materiali pregiati e lavorazioni sartoriali.

Poliform presents the collection of upholstered furniture. Sofas and armchairs that decorate the most exclusive living areas and all the environments in the house where there are spaces to dedicate to comfort and relaxation. Fixed or modular sofas designed to become the protagonists of the day area and armchairs with enveloping volumes. The style is that of Poliform – between excellent design, fine materials, and tailored details.

COLLECTIONS

DIVANI  
SOFAS

7

POLTRONE  
ARMCHAIRS

279

# SOFAS

Una collezione di divani che interpreta tutti gli stili del living contemporaneo: è quella che Jean-Marie Massaud e Carlo Colombo hanno disegnato per Poliform. Sistemi che offrono la massima libertà compositiva, costituiti da elementi componibili che creano vere e proprie isole di comfort, ideali per il riposo e la convivialità. Proposte destinate a farsi notare nella zona giorno per il loro design esclusivo e i dettagli sartoriali.

Jean-Marie Massaud and Carlo Colombo designed for Poliform a sofas collection which interprets all the styles of contemporary living. True systems offering the highest compositional freedom thanks to modular elements that create real islands of comfort, ideal for rest and conviviality. Projects which stand out in the living area for their exclusive design and tailored details.

## SOFAS

SAINT-GERMAIN	11
BRISTOL	55
MONDRIAN	101
WESTSIDE	147
BELLPORT	181
DUNE	215
SYDNEY	237
SHANGAI	251
PARIS SEOUL	265

# SAINT-GERMAIN



Saint-Germain è un sistema di divani ed elementi imbottiti dalle forme sinuose e sensuali. Un segno avvolgente e rotondo ricorre in tutti i moduli della serie, con cui si creano divani lineari, configurazioni a L o composizioni organiche. Il rivestimento, in tessuto o pelle, valorizza i volumi, pieni e voluttuosi. Progettato da Jean-Marie Massaud, Saint-Germain trasforma qualsiasi spazio in un paesaggio caldo e familiare, infondendo una piacevole sensazione di comfort domestico.

Saint-Germain is a system of sofas and upholstered elements with sinuous and sensual shapes. An enveloping and round style recurs in all the modules of the series, which features linear sofas, L-shaped configurations or organic compositions. The covering, in fabric or leather, enhances the full and voluptuous volumes. Designed by Jean-Marie Massaud, Saint-Germain transforms any space into a warm and familiar landscape, giving a pleasant sensation of domestic comfort.





Qui, nelle pagine precedenti e nella successiva: divano Saint-Germain in tessuto sfoderabile Siro 01 bianco, cuscini in tessuto Brest 11 cioccolato, velluto Persia 2002 bruciato e velluto Glasgow 01 crema, piedini brown nickel opaco. Poltrone Le Club in pelle non sfoderabile Silk 06 roccia. Tavolini Koishi, al centro con piani in marmo sahara noir levigato finitura poliestere, accanto al divano con piano in marmo zecevo levigato, strutture brunito opaco. Tavolini Orbit, piano e struttura in vetro bronzato. Contenitori Code con vani a giorno in laccato opaco bronzo, cassetti e fianchi in laccato opaco visone, top retroilluminato in laccato opaco bronzo e zoccolino in ardesia opaco. Tappeto Cannelé.

This, previous pages and next page: Saint-Germain sofa in removable fabric Siro 01 bianco, cushions in fabric Brest 11 cioccolato, velvet Persia 2002 bruciato and velvet Glasgow 01 crema, mat brown nickel feet. Le Club armchairs in non-removable leather Silk 06 roccia. Koishi coffee tables, in the centre with tops in mat marble sahara noir polyester finish, next to the sofa with top in mat marble zecevo, mat brunito structures. Orbit coffee tables, top and structure in bronzed glass. Code open storage units in mat lacquer bronzo, drawers and sides in mat lacquer visone, backlit top in mat lacquer bronzo and mat ardesia plinth. Carpet Cannelé.







In questa pagina: divano Saint-Germain in tessuto sfoderabile Siro 01 bianco, cuscini in tessuto Brest 11 cioccolato, velluto Persia 2002 bruciato e velluto Glasgow 01 crema, piedini brown nickel opaco. Poltrone Le Club in pelle non sfoderabile Silk 06 roccia. Tavolini Koishi, al centro con piani in marmo sahara noir levigato finitura poliesteri, accanto al divano con piano in marmo zecevo levigato, strutture brunito opaco. Tavolini Orbit, piano e struttura in vetro bronzato. Tappeto Cannelé.

This page: Saint-Germain sofa in removable fabric Siro 01 bianco, cushions in fabric Brest 11 cioccolato, velvet Persia 2002 bruciato and velvet Glasgow 01 crema, mat brown nickel feet. Le Club armchairs in non-removable leather Silk 06 roccia. Koishi coffee tables, in the centre with tops in mat marble sahara noir polyester finish, next to the sofa with top in mat marble zecevo, mat brunito structures. Orbit coffee tables, top and structure in bronzed glass. Carpet Cannelé.





Qui e nella pagina precedente: divano Saint-Germain con rivestimento sfoderabile in tessuto Agadir 06 ocra, cuscini in velluto Persia 1404 carbone e piedini brown nickel opaco. Tavolino Saint-Germain con piano in pietra ebano spatolata e struttura brunito opaco. A destra: dettaglio del tavolino Saint-Germain inserito tra due elementi del divano. Nella pagina successiva: divano Saint-Germain con rivestimento sfoderabile in tessuto Siro 01 bianco, cuscini in tessuto Brest 11 cioccolato e in velluto Persia 2002 bruciato, piedini brown nickel opaco.

This and previous page: Saint-Germain sofa with removable cover in fabric Agadir 06 ocra, cushions in velvet Persia 1404 carbone and mat brown nickel feet. Saint-Germain coffee table with top in spatula-finish ebony stone and structure mat brunito. Right: close up of the Saint-Germain coffee table inserted between two sofa elements. Next page: Saint-Germain sofa with removable cover in fabric Siro 01 bianco, cushions in fabric Brest 11 cioccolato and in velvet Persia 2002 bruciato, mat brown nickel feet.











Qui e nella pagina precedente: divano Saint-Germain in tessuto sfoderabile Agadir 03 pepe, cuscini in tessuto Nancy 100 cenere e velluto Persia 1404 carbone, piedini brown nickel opaco. Tavolini Koishi con piano in marmo zecevo levigato e struttura champagne opaco. Tavolino Orbit con piano e struttura in vetro bronzato. Poltrone Le Club in pelle non sfoderabile Silk 01 crema. Mada Symphony in rovere gold con top in marmo zecevo levigato, vano a giorno e basamento con piedini in brown nickel opaco. Boiserie Code in tessuto lino é cru con profili in champagne opaco. Libreria Lexington in rovere gold e champagne opaco. Tappeto Relief cammello.

This and previous page: Saint-Germain sofa in removable fabric Agadir 03 pepe, cushions in fabric Nancy 100 ruggine and velvet Persia 1404 carbone, mat brown nickel feet. Koishi coffee tables with top in mat marble zecevo and mat champagne structure. Orbit coffee table with top and structure in bronzed glass. Le Club armchairs in non-removable leather Silk 01 crema. Symphony sideboard in gold oak with top in mat marble zecevo, open storage units and base with feet in mat brown nickel. Code wall panelling in fabric lino é cru with mat champagne profiles. Lexington bookcase in gold oak and mat champagne. Carpet Relief cammello.





Qui e nella pagina precedente: divano Saint-Germain Boomerang con rivestimento sfoderabile in pelle Nabuk 01 latte, cuscini in tessuto Brest 04 pepe e in velluto Persia 1404 carbone, piedini brown nickel opaco. Nella pagina successiva: divano Saint-Germain con rivestimento sfoderabile in tessuto Lima 67 pernice, cuscini in velluto Glasgow 03 carbone, piedini brown nickel opaco.

This and previous page: Saint-Germain Boomerang sofa with removable cover in leather Nabuk 01 latte, cushions in fabric Brest 04 pepe and in velvet Persia 1404 carbone, mat brown nickel feet. Next page: Saint-Germain sofa with removable cover in fabric Lima 67 pernice, cushions in velvet Glasgow 03 carbone, mat brown nickel feet.







Qui e nella pagina successiva: divano Saint-Germain in tessuto sfoderabile Brest 02 salvia, cuscini in velluto Tebe 07 oliva, piedini brown nickel opaco. Tavolino Koishi con piano in marmo zecevo levigato e struttura brunito opaco. Pouf New York, tondo in velluto sfoderabile Persia 1404 carbone, rettangolare in pelle non sfoderabile Soft 14 oliva, entrambi con piedini brown nickel lucido. Cabina armadio Lexington in champagne opaco, nobilitato olmo, tecnocover Grain 05 latte, cassettiere a vetrina in laccato opaco champagne e cassetti inferiori in vetro riflettente fumé. Boiserie Code in tessuto lino écreu con profili in champagne opaco. Al centro, armadio Senzafine Ego con ante e fianchi laterali in vetro trasparente riflettente e telaio champagne opaco.

This and next page: Saint-Germain sofa in removable fabric Brest 02 salvia, cushions in velvet Tebe 07 oliva and mat brown nickel feet. Koishi coffee table with top in mat marble zecevo and mat brunito structure. New York poufs, round version in removable velvet Persia 1404 carbone, rectangular version in non-removable leather Soft 14 oliva, both with mat brown nickel feet. Lexington walk-in closet in mat champagne, elm melamine, tecnocover Grain 05 latte, showcase chests of drawers in mat lacquer champagne and lower drawers in fumé reflecting glass. Wall panelling Code in fabric lino ecru with mat champagne profiles. In the centre, Senzafine Ego wardrobe with doors and lateral sides in transparent reflecting glass and mat lacquered champagne frame.





In questa pagina: chaise longue Saint-Germain con rivestimento sfo-  
derabile in tessuto Kitami 04 sabbia, cuscino in velluto Persia 1404  
carbone, piedini brown nickel opaco.

This page: Saint-Germain chaise longue with removable cover in fabric  
Kitami 04 sabbia, cushion in velvet Persia 1404 carbone, mat brown  
nickel feet.

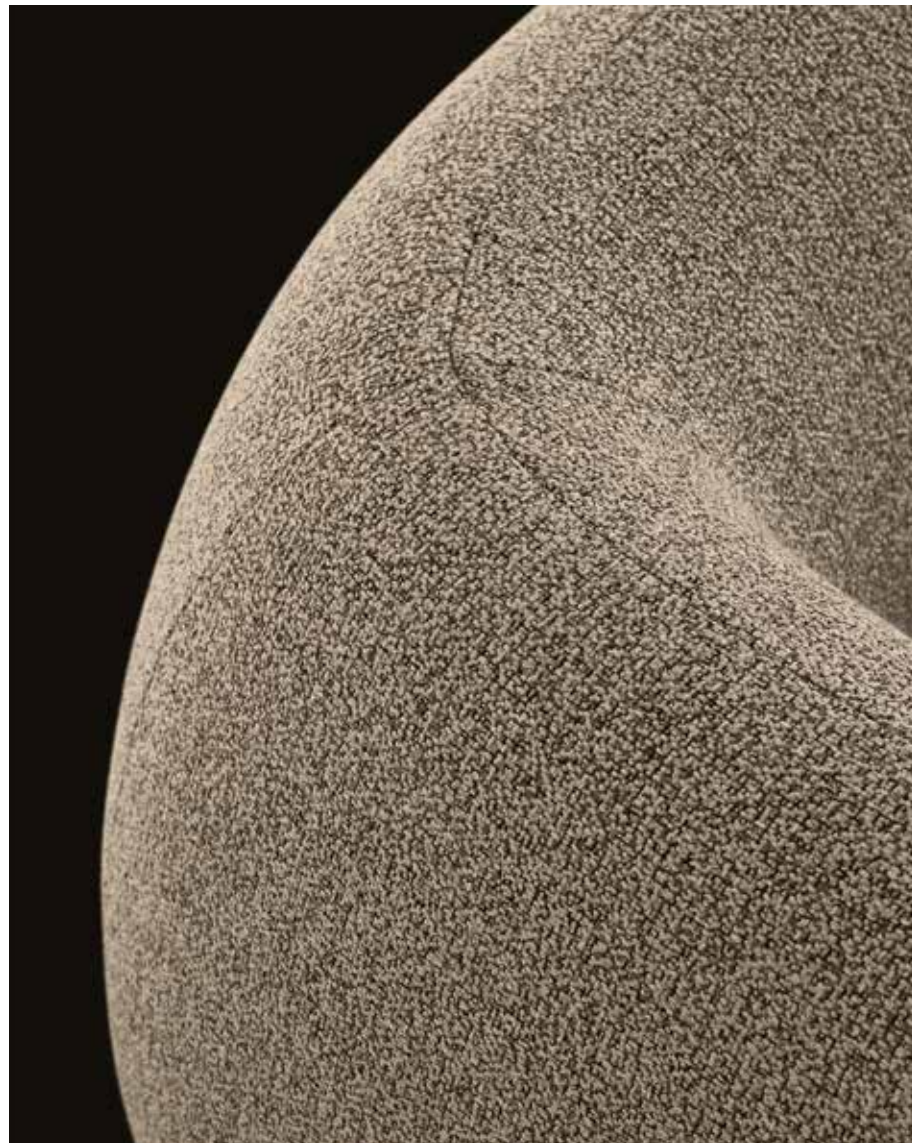





In questa pagina: pouf Saint-Germain, versione grande in pelle sfoderabile Deep 02 sabbia, versione piccola in tessuto sfoderabile Brest 12 sabbia, entrambi con piedini brown nickel opaco.

This page: Saint-Germain poufs, big version in removable leather Deep 02 sabbia, small version in removable fabric Brest 12 sabbia, both with mat brown nickel feet.





Qui e nella pagina precedente: divano Saint-Germain Boomerang in pelle sfoderabile Nabuk 06 mastice, cuscini in tessuto Brest 05 danubio e velluto Glasgow 04 avio, piedini brown nickel opaco. Pouf Saint-Germain, versione grande in tessuto sfoderabile Siro 01 bianco, versione piccola in pelle sfoderabile Nabuk 06 mastice, entrambi con piedini brown nickel opaco. Tavolino Koishi con piano in marmo zecevo levigato e struttura brunito opaco. Poltrona Gentleman Relax in tessuto sfoderabile Siro 02 lino e basamento in brown nickel lucido. Armadio Senzafine Cover e boiserie Code in tessuto lino bruciato e champagne opaco. Sistema Code integrato in rovere gold e laccato metallico ottone. Tappeto Cannelé.

This and previous page: Saint-Germain Boomerang sofa in removable leather Nabuk 06 mastice, cushions in fabric Brest 05 danubio and velvet Glasgow 04 avio, mat brown nickel feet. Saint-Germain poufs, big version in removable fabric Siro 01 bianco, small version in removable leather Nabuk 06 mastice, both with mat brown nickel feet. Koishi coffee table with top in mat marble zecevo and mat brunito structure. Gentleman Relax armchair in removable fabric Siro 02 lino and base in glossy brown nickel. Senzafine Cover wardrobe and Code wall panelling in fabric lino bruciato and mat champagne. Integrated Code system in gold oak and metal lacquer ottone. Carpet Cannelé.



## SAINT-GERMAIN

Design Jean-Marie Massaud

Struttura in legno e derivati. Schienale in poliuretano flessibile stampato, cuscino seduta in poliuretano espanso a quote differenziate, priverestimento in tela cotone e piuma.

Cuscino schienale in poliuretano espanso e piuma, larghezza mm 600-700-800.

Cuscino poggiatesta opzionale in strutturato e piuma, larghezza mm 700.

Cuscini opzionali in tela cotone e piuma.

Piedini regolabili in metallo verniciato brown nickel opaco.

Rivestimento sfoderabile in tessuto o pelle.

Tavolino terminale o da inserire tra due elementi solo con la profondità della seduta di 790 (profondità divano 1000). Struttura tavolino in metallo verniciato brunito opaco o champagne opaco; piano in olmo nero, rovere gold, vetro blu riflettente, pietra ebano spatolata o sei marmi levigati e sei lucidi.

Structure in wood and wood by-products.

Backrest in flexible moulded polyurethane, seat cushion in multi-density polyurethane foam, pre-cover in cotton canvas and down.

Fixed backrest cushion in polyurethane foam and down, width 23 1/2"-27 1/2"-31 1/2".

Optional structural headrest cushion in down, width 27 1/2".

Optional cushions in cotton canvas and down.

Levelling feet in painted metal mat brown nickel.

Removable cover in fabric or leather.

End or central coffee table inserted between two elements only available with seat depth 31" (sofa depth 39 1/4").

Structure coffee table in metal painted mat brunito or mat champagne; top in black elm, gold oak, blu reflecting glass, ebony stone with spatula finish or six mat and six glossy marbles.

### Divano Sofa

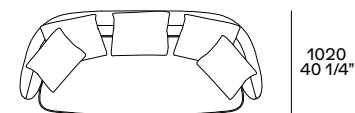
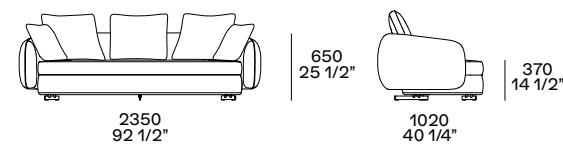

### Divano composto Modular sofa

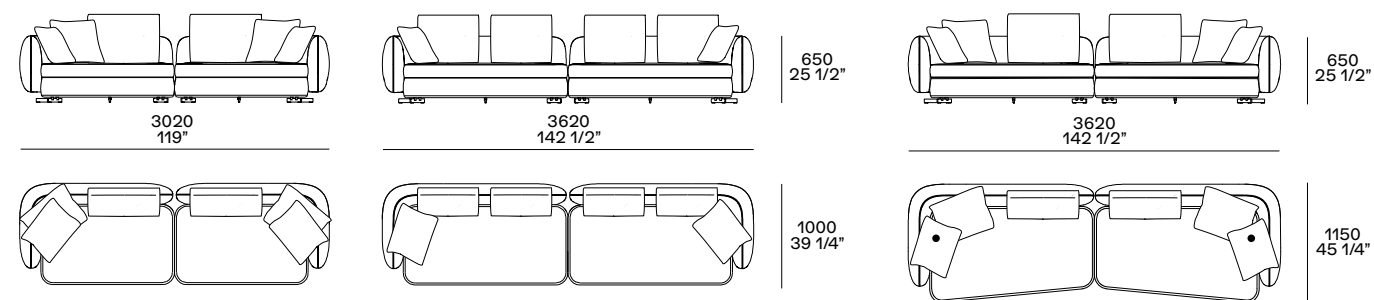

### Cuscini opzionali Optional cushions



### Divano Boomerang sx-dx Lt-rt Boomerang sofa

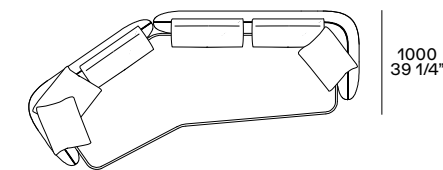
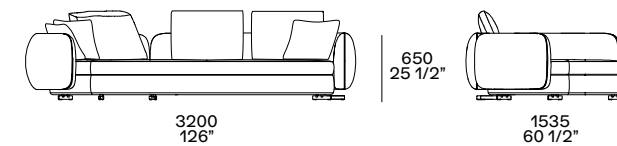

### Cuscino poggiatesta opzionale Optional headrest cushion

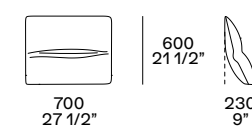

- può sostituire il cuscino schienale fisso e, solo dove indicato, i cuscini opzionali it can replace the fixed backrest cushion and, only where indicated, the optional cushions

### Elemento centrostanza sx-dx Lt-rt freestanding element

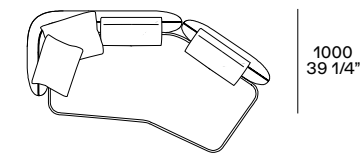
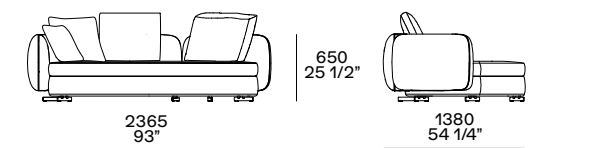

terminale sx-dx  
lt-rt end unit

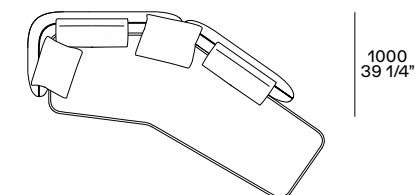
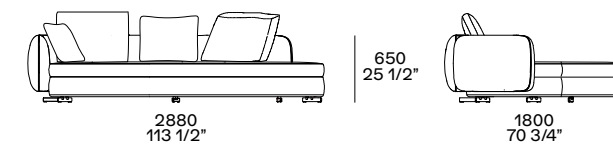

terminale penisola sx-dx  
lt-rt peninsula end unit

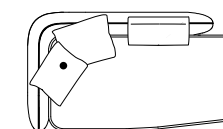
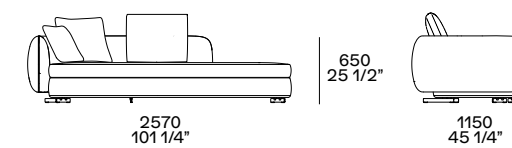

angolo penisola sx-dx  
lt-rt peninsula corner unit

### Pouf centrostanza Freestanding pouf

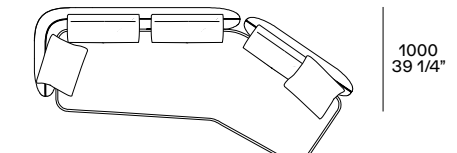
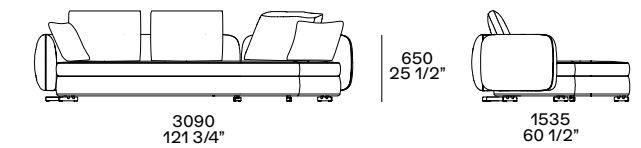
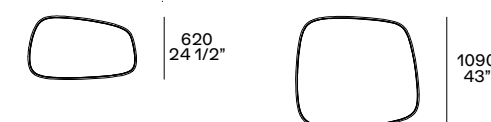
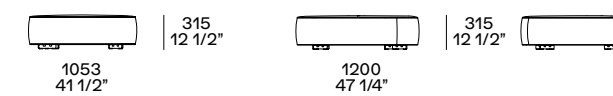

terminale sx-dx  
lt-rt end unit

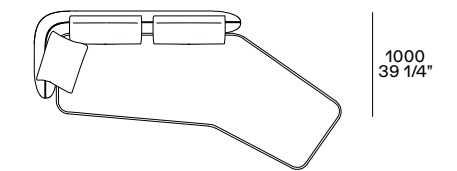
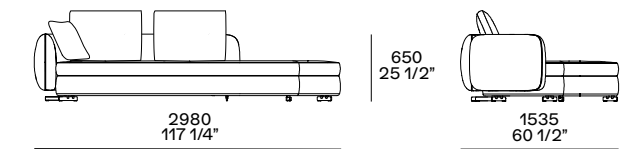

terminale penisola sx-dx  
lt-rt peninsula end unit

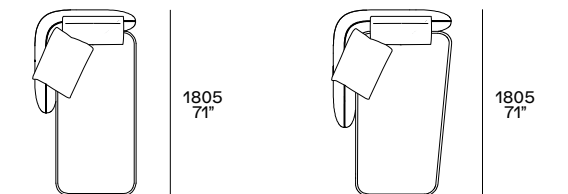
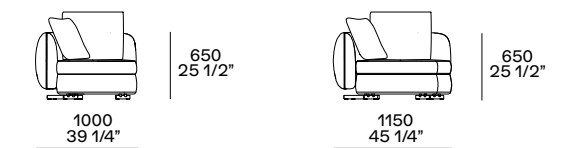

chaise longue sx-dx  
lt-rt chaise longue

**Cuscini schienale**  
**Backrest cushions**

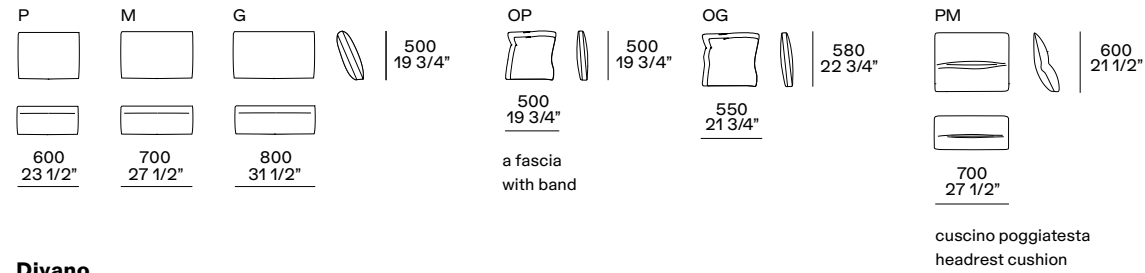

• Il cuscino poggiatesta può sostituire il cuscino schienale fisso e, solo dove indicato, i cuscini opzionali.  
The headrest cushion can replace the fixed backrest cushion and, only where indicated, the optional cushions.

**Divano**  
**Sofa**

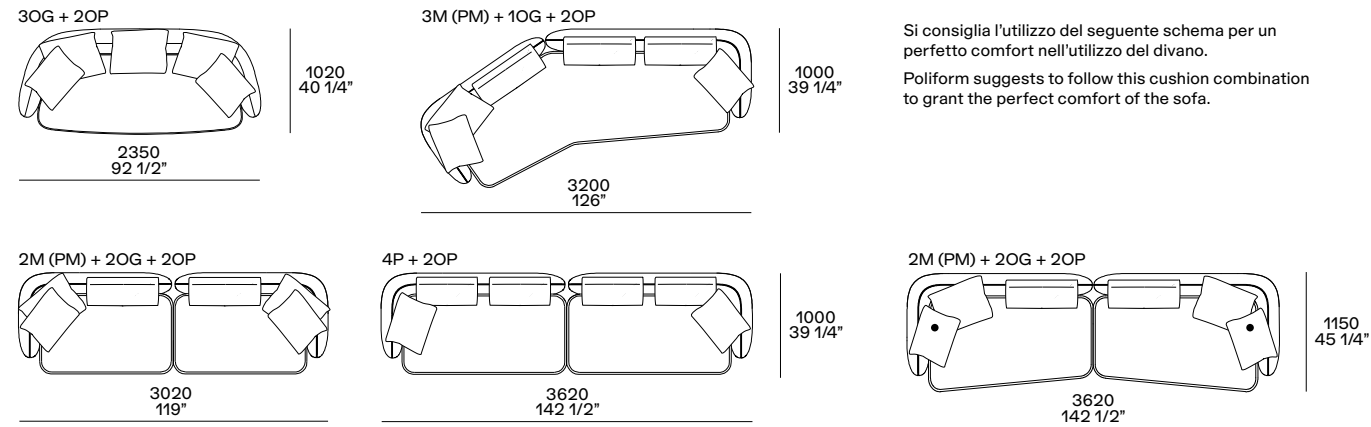

Si consiglia l'utilizzo del seguente schema per un perfetto comfort nell'utilizzo del divano.  
Poliform suggests to follow this cushion combination to grant the perfect comfort of the sofa.

**Terminale sx-dx**  
**Lt-rt end unit**

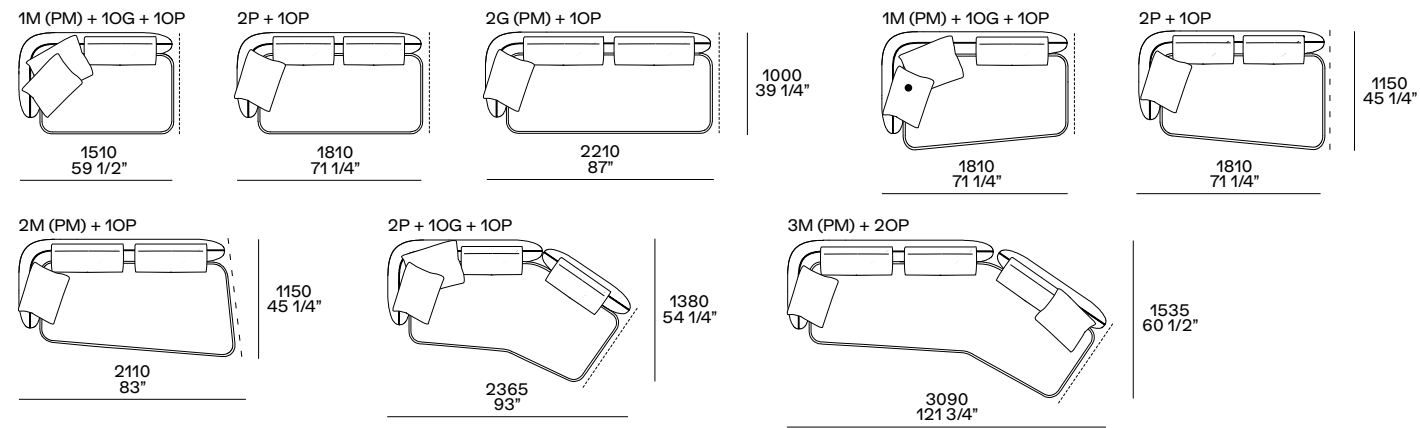

**Terminale penisola sx-dx**  
**Lt-rt peninsula end unit**

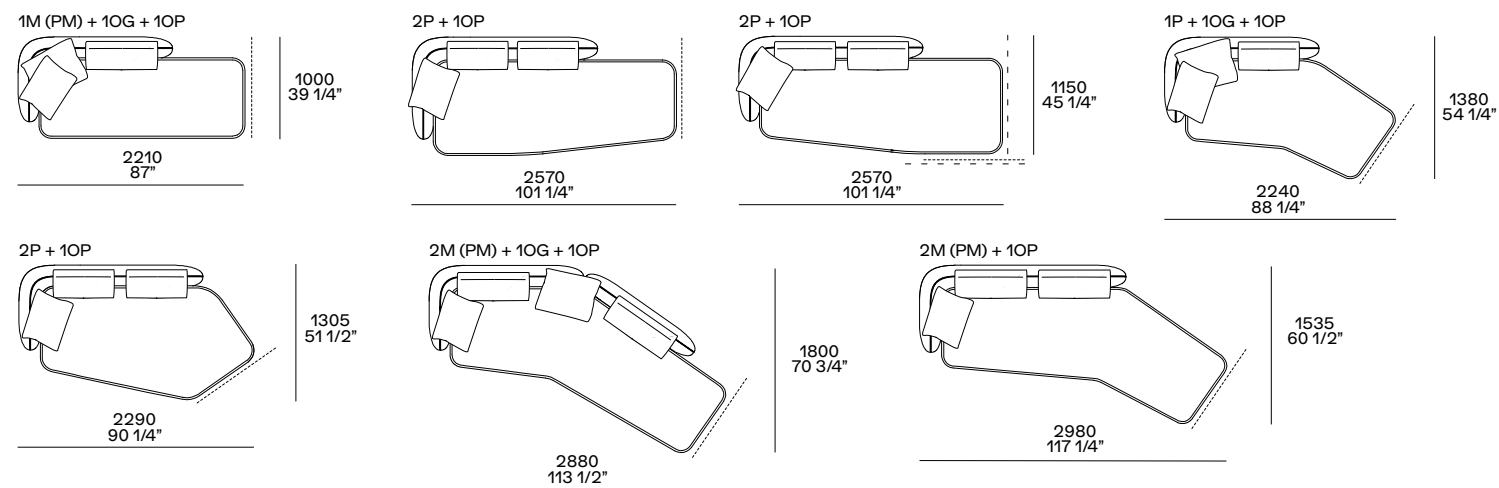

**Centrale**  
**Central unit**

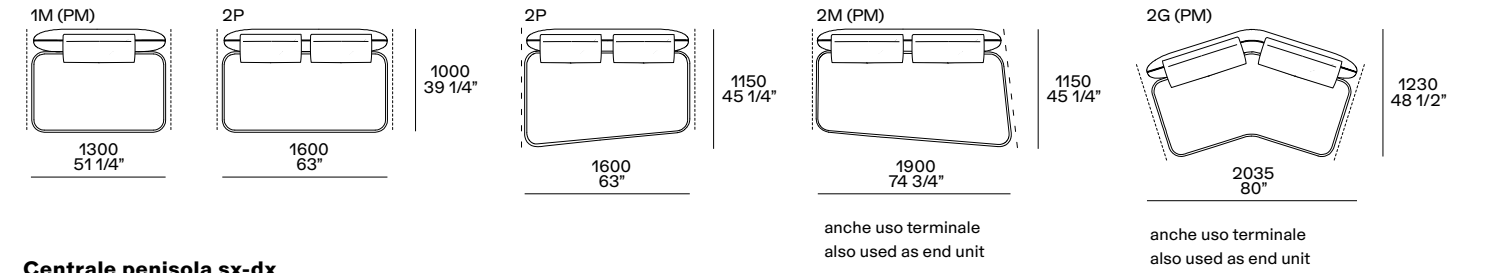

anche uso terminale  
also used as end unit

anche uso terminale  
also used as end unit

**Centrale penisola sx-dx**  
**Lt-rt peninsula central unit**

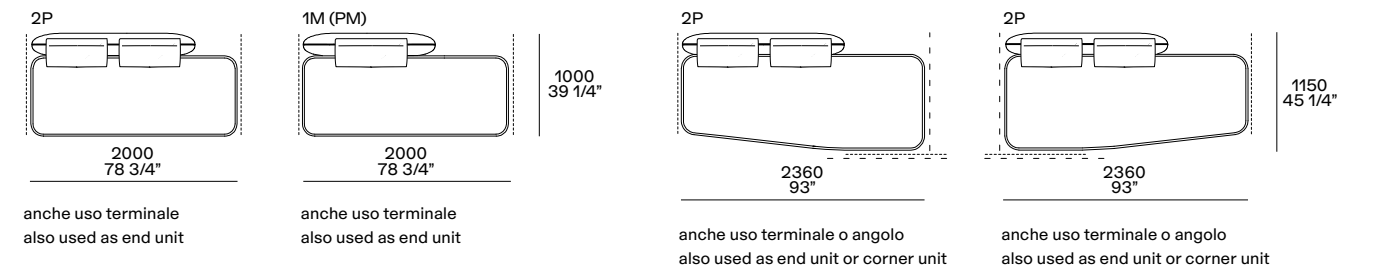

anche uso terminale  
also used as end unit

anche uso terminale  
also used as end unit

anche uso terminale o angolo  
also used as end unit or corner unit

anche uso terminale o angolo  
also used as end unit or corner unit

**Angolo sx-dx**  
**Lt-rt corner unit**

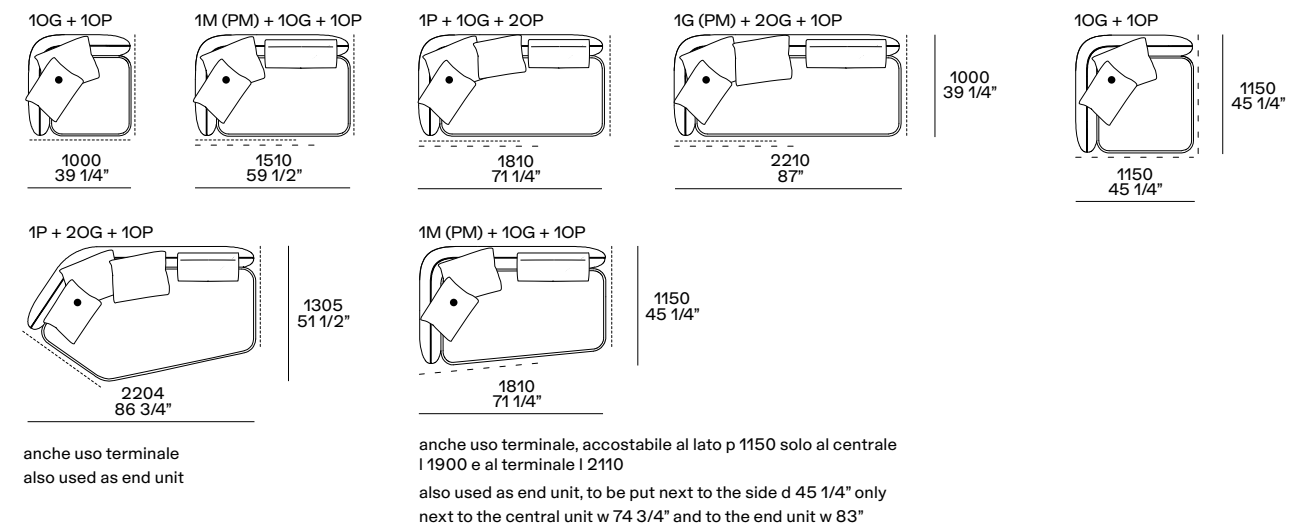

anche uso terminale  
also used as end unit

anche uso terminale, accostabile al lato p 1150 solo al centrale I 1900 e al terminale I 2110  
also used as end unit, to be put next to the side d 45 1/4" only next to the central unit w 74 3/4" and to the end unit w 83"

**Angolo penisola sx-dx**  
**Lt-rt peninsula corner unit**

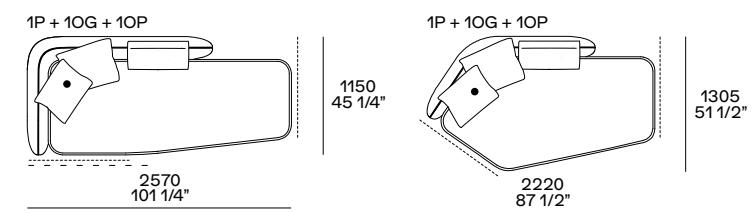

**Chaise longue sx-dx**  
**Lt-rt chaise longue**

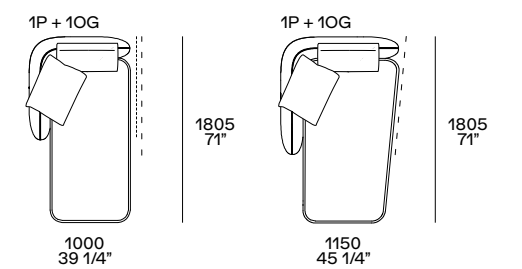

accostabile solo al terminale I 2110  
to be put only next to the end-unit w 83"

**Tavolino**  
**Coffee table**

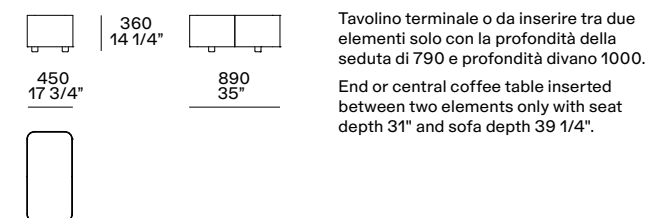

Tavolino terminale o da inserire tra due elementi solo con la profondità della seduta di 790 e profondità divano 1000.

End or central coffee table inserted between two elements only with seat depth 31" and sofa depth 39 1/4".

profondità 1150 - seduta 940  
depth 45 1/4" - seat 37"

profondità 1000 - seduta 790  
depth 39 1/4" - seat 31"

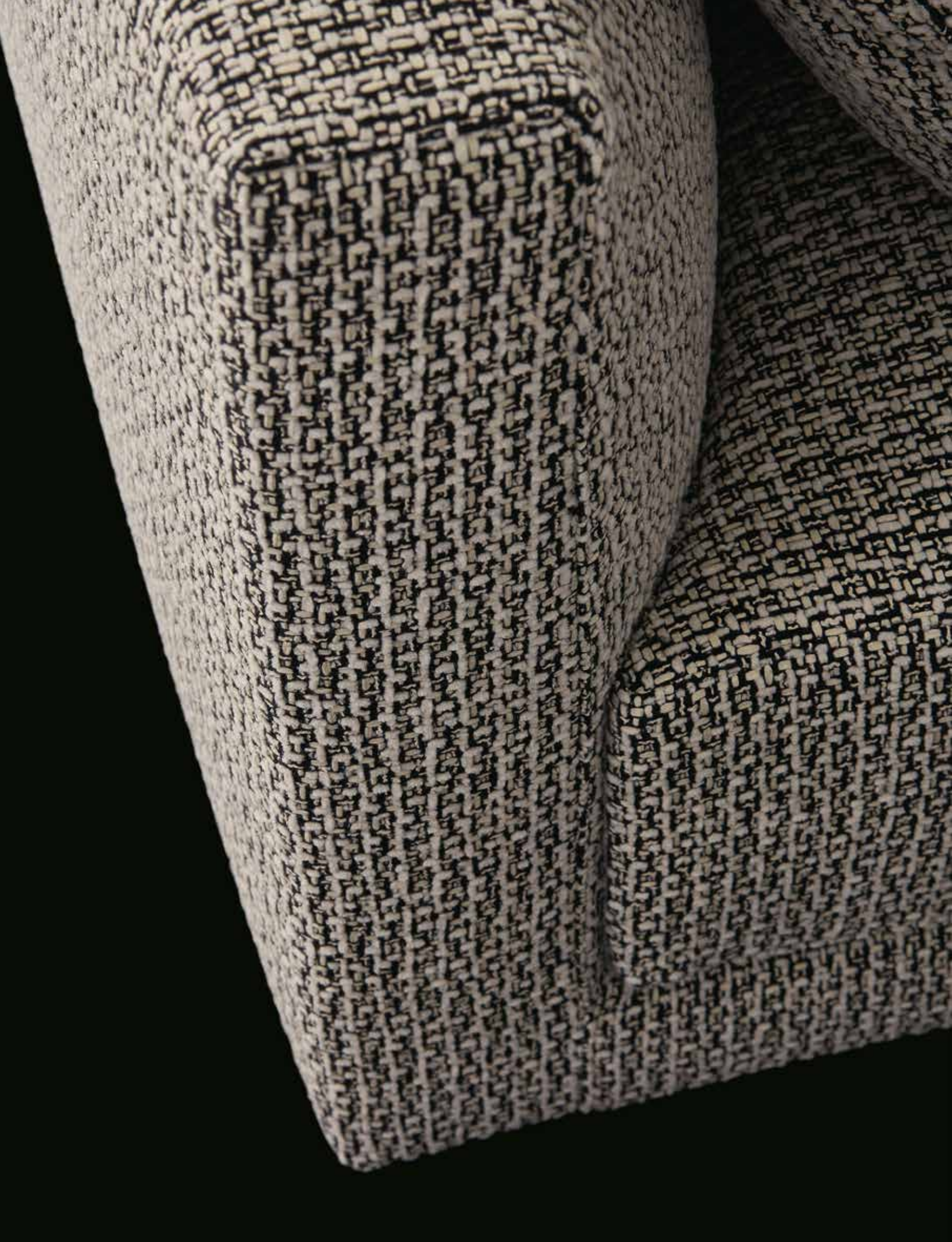

# BRISTOL

Il comfort avvolgente della cuscinatura e la leggerezza dei braccioli contraddistinguono l'estetica di Bristol. Il sistema offre la massima versatilità compositiva: disponibile sia in versione fissa sia componibile, in quest'ultimo caso si configura a piacere per creare divani lineari, ad angolo, oppure nelle più contemporanee forme curve, che si realizzano con l'elemento angolare inclinato. Bristol è disponibile con cuscinatura semplice, doppia, libera o comfort, con soffice imbottitura in piuma.

The enveloping comfort of the cushions and the lightness of the armrests distinguish the style of Bristol. The system offers maximum compositional versatility: available in fixed or modular version. The modular version can be composed to create linear, corner or more contemporary curved shapes that can be realized using the inclined corner element. Available with simple, double, free or comfort cushions with soft feather padding.









Qui e nelle pagine precedenti: divano Bristol con cuscineratura singola, rivestimento sfoderabile in tessuto Naxos 17 corda con cuscini in tessuto Nancy 101 carbone. Poltrona Jane in velluto sfoderabile Persia 54 prussia e basamento in olmo nero. Tavolino Home Hotel in olmo nero. Tavolino Baba in metallo verniciato oro lucido e piano in vetro oro. Pouf Henry in olmo nero e seduta non sfoderabile in velluto Persia 1404 carbone. Tappeto Frame carbone.

This and previous pages: Bristol sofa with single backrest cushion, removable cover in fabric Naxos 17 corda with cushions in fabric Nancy 101 carbone. Jane armchair in removable velvet Persia 54 prussia and base in black elm. Home Hotel coffee table in black elm. Baba coffee table in glossy gold painted metal and top in gold glass. Henry pouf in black elm with seat in non-removable velvet Persia 1404 carbone. Carpet Frame carbone.







Qui e nella pagina precedente: divano Bristol con cuscinatura singola, rivestimento sfoderabile in pelle Nabuk 08 prussia, cuscini in tessuto Sendai 05 navy e in pelle Nabuk 08 prussia, piedini opzionali in brown nickel lucido.

This and previous page: Bristol sofa with single backrest cushion, removable cover in leather Nabuk 08 prussia, cushions in fabric Sendai 05 navy and in leather Nabuk 08 prussia, optional feet in glossy brown nickel.





Qui e nella pagina precedente: divano Bristol con cuscinatura comfort, rivestimento sfoderabile in tessuto Sheffield 01 pepe, cuscini poggiatesta in tessuto Dundee 01 pepe e cuscini opzionali in tessuto Norwich 01 bianco. Bracciolo fisso con struttura in brown nickel lucido. Libreria Lexington con montanti a parete in olmo nero e ardesia opaco con piedini di regolazione in nickel ardesia. Ripiani e contenitori con ante a ribalta e cassetti in olmo nero e ardesia opaco. Tavolini Mondrian con struttura in brown nickel lucido e piani in marmo verde lepanto opaco. Poltrona Mad Chair in velluto sfoderabile Persia 1404 carbone e gambe in olmo nero. Boiserie Code in tessuto lino bruciato e profili in champagne opaco, mensolone in olmo nero. Tappeto Plain natural.

This and previous page: Bristol sofa with backrest cushion comfort, removable cover in fabric Sheffield 01 pepe, lower back cushions in fabric Dundee 01 pepe and optional cushions in fabric Norwich 01 bianco. Fixed armrest with structure in glossy brown nickel. Lexington bookcase with wall mounted uprights in black elm and mat ardesia with levelling feet in nickel ardesia. Shelves and storage units with flap doors and drawers in black elm and mat ardesia. Mondrian coffee tables with glossy brown nickel structure and tops in mat marble verde lepanto. Mad Chair armchair in removable velvet Persia 1404 carbone and black elm legs. Code wall panelling in fabric lino bruciato and mat champagne profiles, thick shelf in black elm. Carpet Plain natural.







Nella pagina precedente: divano Bristol con cuscinatura comfort, rivestimento sfoderabile in tessuto Sheffield 01 pepe, cuscini poggiatesta in tessuto Dundee 01 pepe e cuscini opzionali in tessuto Norwich 01 bianco. Bracciolo fisso con struttura in brown nickel lucido. In questa pagina e nella successiva: divano Bristol con cuscinatura comfort, rivestimento sfoderabile in tessuto Kitami 04 sabbia, cuscini poggiatesta in velluto Glasgow 03 carbone e cuscini opzionali in tessuto Lero 01 écru.

Previous page: Bristol sofa with backrest cushion comfort, removable cover in fabric Sheffield 01 pepe, lower back cushions in fabric Dundee 01 pepe and optional cushions in fabric Norwich 01 bianco. Fixed armrest with structure in glossy brown nickel. This and previous page: Bristol sofa with backrest cushion comfort, removable cover in fabric Kitami 04 sabbia, lower back cushions in velvet Glasgow 03 carbone and optional cushions in fabric Lero 01 ecru.

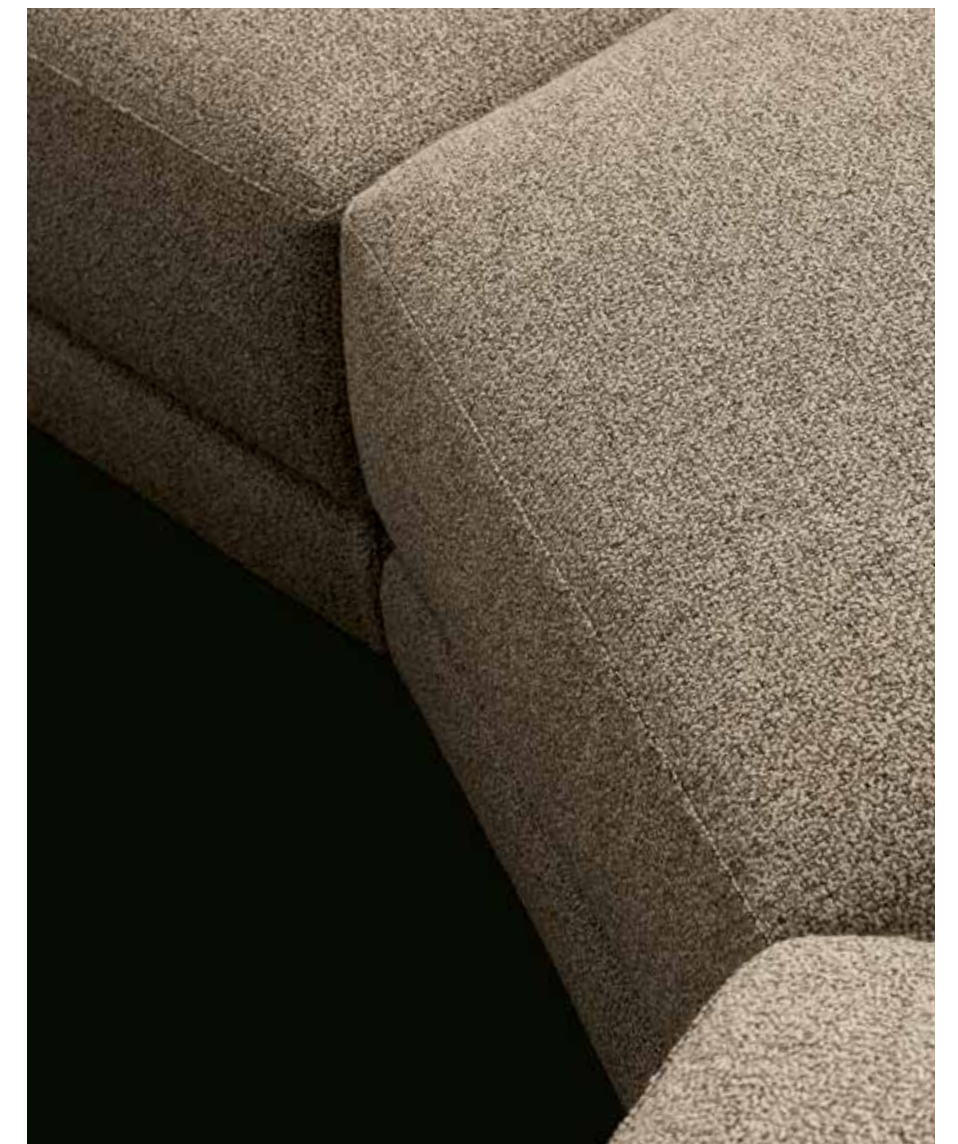







Qui e nella pagina successiva: divano Bristol con cuscinata doppia, rivestimento sfoderabile in tessuto Rabat 412 cemento, cuscini in velluto Persia 1404 carbone e 1403 ocra. Pouf Bristol rivestimento sfoderabile in velluto Persia 1404 carbone. Madia e tavolini Bristol in olmo nero, piedini in brown nickel opaco. Tavolino Baba in brown nickel opaco e piano in marmo emperador dark levigato. Poltrone Mad Chair in velluto sfoderabile Persia 1404 carbone, gambe in olmo nero. Composizione Wall System laccato lucido moka e olmo nero, ante scorrevoli Bold in cuoio 02 nero. Sotto: dettaglio del bracciolo fisso opzionale per elementi terminali.

This and next page: Bristol sofa with double backrest cushion, removable cover in fabric Rabat 412 cemento, cushions in velvet Persia 1404 carbone and 1403 ocra. Bristol pouf with removable cover in velvet Persia 1404 carbone. Sideboard and coffee table Bristol in black elm, mat brown nickel feet. Baba coffee table in mat brown nickel and top in mat marble emperador dark. Mad Chair armchairs in removable velvet Persia 1404 carbone, legs in black elm. Wall Sytem composition in moka glossy lacquer and black elm, Bold sliding doors in hide 02 nero. Below: close up of the optional fixed arm for end units.









Nella pagina precedente: divano Bristol con cuscinata doppia e poggiatesta, rivestimento sfoderabile in tessuto Olimpia 111 castagna, cuscini opzionali in velluto Persia 1404 carbone, piedini opzionali in brown nickel lucido. In questa pagina e nella successiva: divano Bristol con cuscinata doppia e poggiatesta, rivestimento sfoderabile in tessuto Sheffield 09 burro, cuscini tessuto Sendai 03 fango e in velluto Persia 1404 carbone, piedini opzionali in brown nickel lucido. Sotto: dettaglio del poggiatesta utilizzabile esclusivamente con cuscinata doppia.

Previous page: Bristol sofa with double backrest cushion and headrest, removable cover in fabric Olimpia 111 castagna, optional cushions in velvet Persia 1404 carbone, optional feet in glossy brown nickel. This and next page: Bristol sofa with double backrest cushion and headrest, removable cover in fabric Sheffield 09 burro, cushions in fabric Sendai 03 fango and in velvet Persia 1404 carbone, optional feet in glossy brown nickel. Below: close up of the headrest to be used only with the version with double backrest cushion.







Nella pagina precedente: divano Bristol con cuscinata libera e cuscinata singola, rivestimento sfoderabile in tessuto Milos 05 cemento, cuscini velluto Persia 1404 carbone, piedini opzionali in brown nickel opaco e tavolini retrodivano Bristol in olmo nero. Tavolino Bristol piano in marmo calacatta oro levigato e in olmo nero, inserti e piedini in brown nickel opaco. Poltrone Mad Joker rivestimento non sfoderabile, esterno in pelle Nabuk 02 tortora e interno in tessuto Argo 1004 cenere, basamento girevole in brown nickel lucido. Pouf Onda in pelle non sfoderabile Soft 04 cognac. In questa pagina: divano Bristol con cuscinata libera in pelle sfoderabile Nabuk 02 tortora, cuscini in tessuto Lima 63 nero e pelle Nabuk 02 tortora. Tavolini Bristol laterale e centrale in rovere spessart, inserti e piedini in brown nickel opaco. Madia Pandora laccato lucido visone. Libreria Wall System in rovere spessart.

Previous page: Bristol sofa with loose cushions and single backrest cushion, removable cover in Milos 05 cemento, cushions in velvet Persia 1404 carbone, optional feet in mat brown nickel and Bristol small tables at the back of the sofa in black elm. Bristol coffee table with top in mat marble calacatta oro and in black elm, inlays and feet in mat brown nickel. Mad Joker armchairs with non-removable cover, outer cover in leather Nabuk 02 tortora and inner cover in fabric Argo 1004 cenere, swivel base in glossy brown nickel. Onda pouf in non-removable leather Soft 04 cognac. This and next page: Bristol sofa with loose cushions in removable leather Nabuk 02 tortora, cushions in fabric Lima 63 nero and leather Nabuk 02 tortora. Central and side Bristol coffee tables in spessart oak, inlays and feet in mat brown nickel. Visone glossy lacquered Pandora sideboard. Wall System bookcase in spessart oak.



## BRISTOL

Design Jean-Marie Massaud, 2013-2021

Struttura in poliuretano flessibile stampato. Cuscino seduta in poliuretano flessibile sagomato, prriverestimento parti in tela cotone e piuma e parti in fibra di poliestere. Cuscinatura comfort, cuscino schienale in piuma con inserto in poliuretano flessibile, prriverestimento in cotone. Cuscinatura singola, cuscino schienale in Solotex, prriverestimento in cotone. Cuscinatura doppia, cuscino schienale anteriore in Solotex, prriverestimento in cotone; cuscino schienale posteriore in poliuretano flessibile, prriverestimento in fibra di poliestere. Cuscinatura libera, cuscini in piuma con prriverestimento in cotone. Cuscini opzionali e poggiatesta in piuma con prriverestimento in cotone. Piedini arretrati in materiale plastico (h 45 di serie e h 65) o piedini opzionali in pressofusione d'alluminio verniciato brown nickel opaco e lucido (h 45). Rivestimento sfoderabile in tessuto o pelle.

Structure in flexible moulded polyurethane. Seat cushion in flexible shaped polyurethane, pre-cover with parts in cotton canvas and down and parts in polyester fibre. Comfort backrest cushion, backrest cushion in down with insert in flexible polyurethane, pre-cover in cotton. Single backrest cushion, backrest cushion in Solotex, pre-cover in cotton cloth. Double backrest cushion, front backrest cushion in Solotex, pre-cover in cotton; back backrest cushion in flexible polyurethane, pre-cover in polyester fibre. Loose cushions, cushions in down with pre-cover in cotton. Optional cushions and lower back cushion in down with pre-cover in cotton. Invisible feet in plastic material (h 1 3/4" standard and 2 1/2") or optional feet in aluminium die casting painted mat and glossy brown nickel (h 1 3/4"). Removable cover in fabric or leather.

### Tipologie cuscinatura schienale Backrest cushion types



cuscinatura comfort  
comfort cushion



cuscinatura singola  
single cushion



cuscinatura doppia  
double cushion



cuscinatura libera  
loose cushions

### Tipologie piedino Feet types



arretrato, h 45 di serie o h 65  
recessed, h 1 3/4" standard or h 2 1/2"



estetico opzionale h 45  
aesthetic optional h 1 3/4"

#### NB

Il divano è disponibile in due altezze:  
- h 660, seduta h 360,  
piedino arretrato di serie o estetico  
opzionale h 45.  
- h 680, seduta h 380,  
piedino arretrato su richiesta h 65.

È sconsigliato per motivi di allineamento  
l'utilizzo degli elementi retro divano  
Bristol System con piedino h 65.

The sofa is available in two heights:  
- h 26", seat h 14 1/4",  
standard recessed feet or aesthetic  
optional feet h 1 3/4".  
- h 26 3/4", seat h 15", recessed  
feet on request h 2 1/2".

For alignment reason it is not recommended  
to use Bristol System furniture with feet  
h 2 1/2".

### Divano con cuscinatura comfort Sofa with backrest cushion comfort

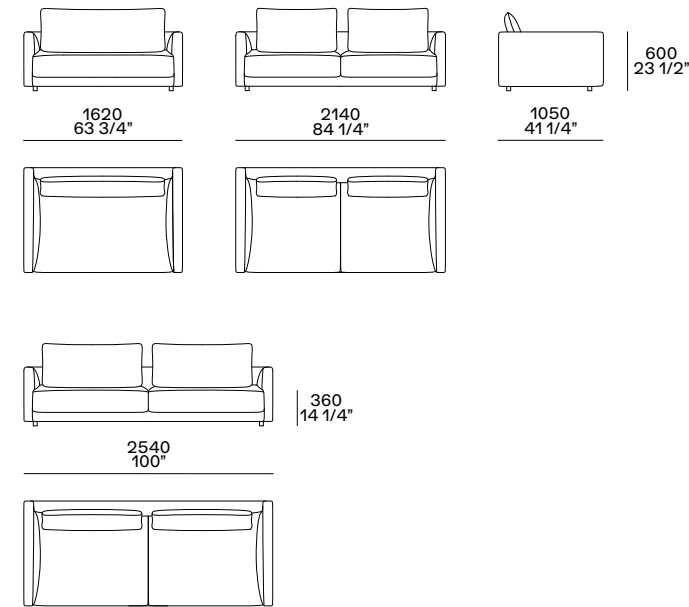

### Divano con cuscinatura singola o doppia Sofa with single or double backrest cushion

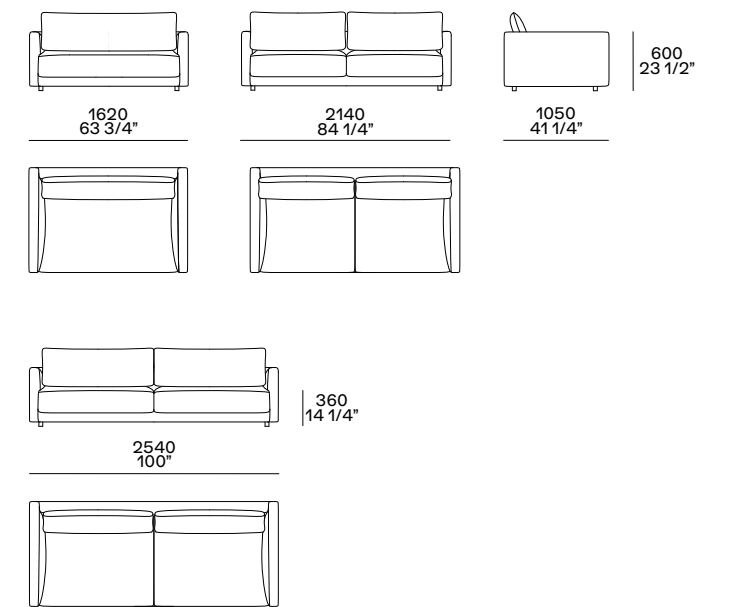

### Divano con cuscinatura libera Sofa with loose cushions

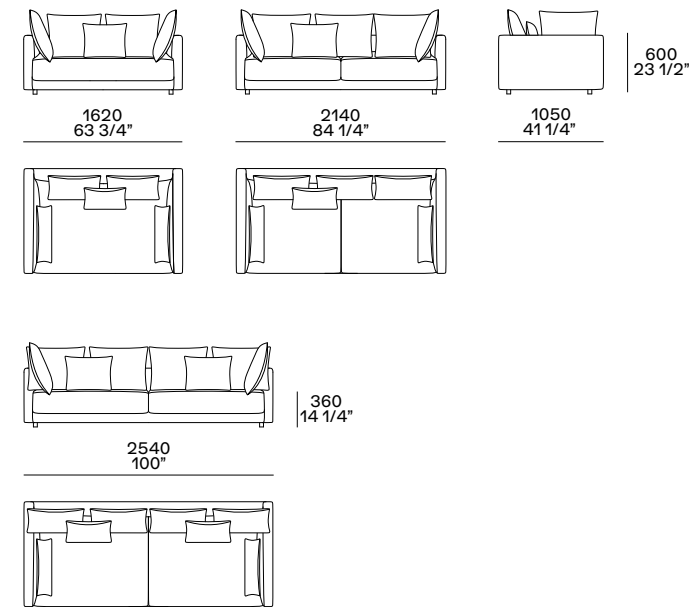

### Poggiatesta Headrest

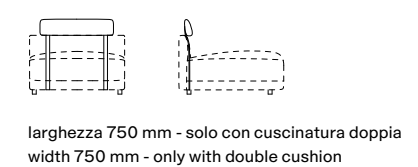

### Bracciolo fisso h 482 Fixed arm h 19"

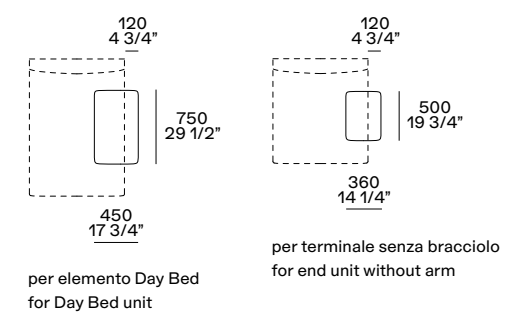

### Pouf centrostanza Freestanding pouf

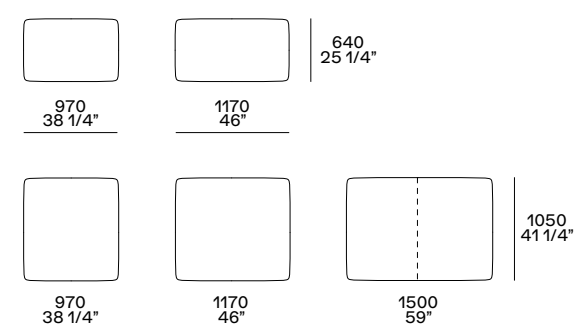

### Cuscini opzionali Optional cushions

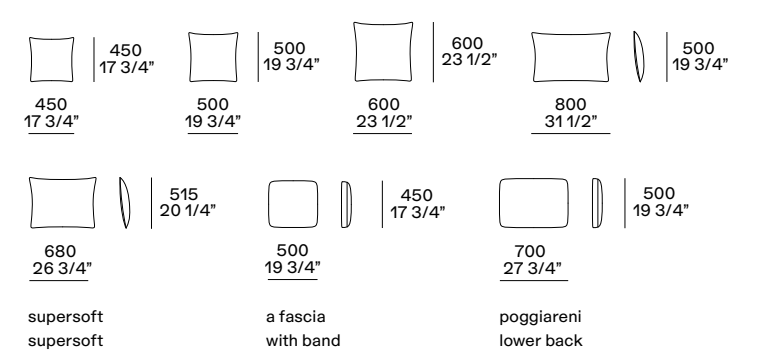



**Bristol cuscinataura comfort**  
**Bristol comfort cushion**

**Cuscini schienale**  
**Backrest cushions**

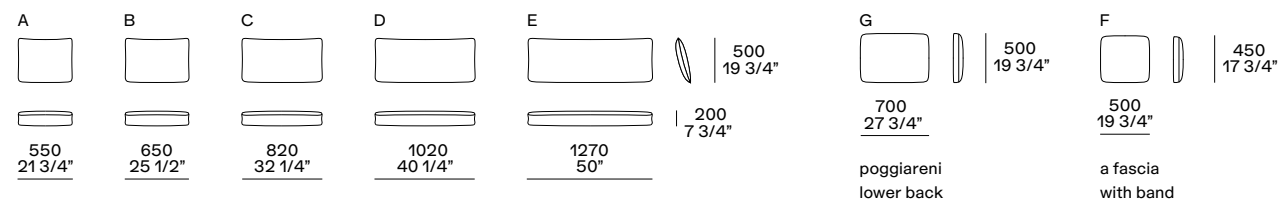

**Divano**  
**Sofa**

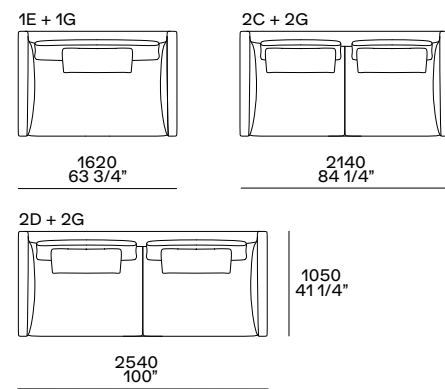

**Terminale sx-dx**  
**Lt-rt end unit**

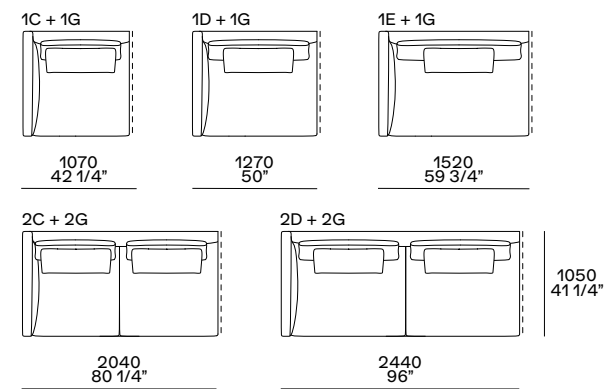

**Terminale senza bracciolo sx-dx**  
**Lt-rt end unit whitout arm**

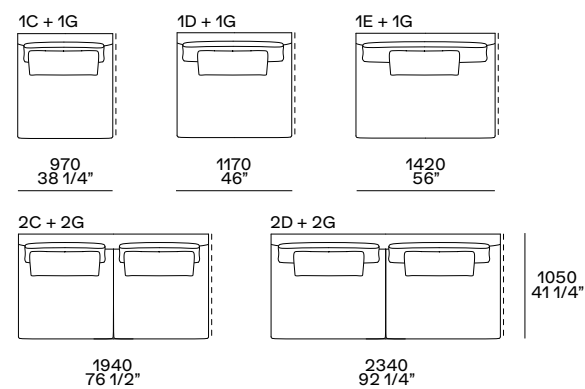

**Centrale**  
**Central unit**

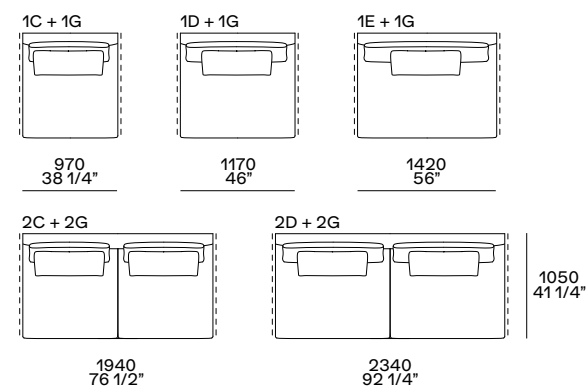

**Angolo sx-dx**  
**Lt-rt corner unit**

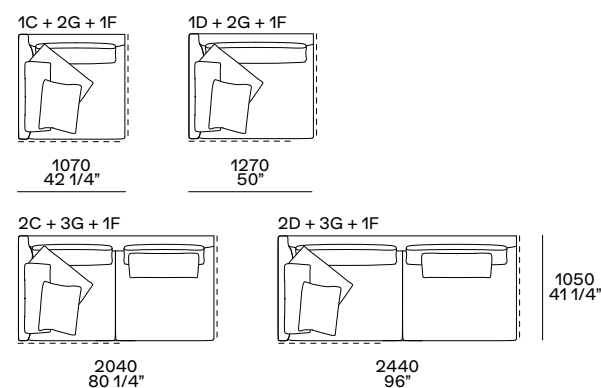

**Terminale angolo sx-dx**  
**Lt-rt corner end unit**

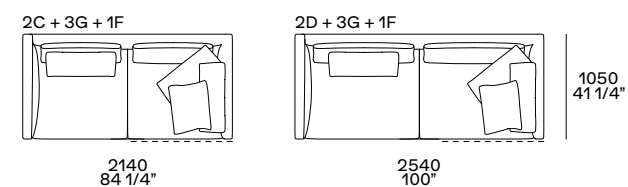

**Elemento inclinato**  
**Angled unit**

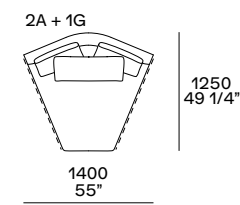

uso terminale o angolo  
 end unit or corner unit

**Elemento inclinato pouf**  
**Angled unit pouf**

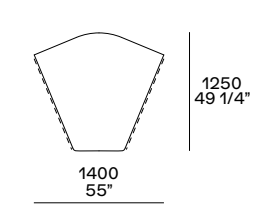

uso terminale o angolo  
 end unit or corner unit

**Chaise longue**  
**Chaise longue**

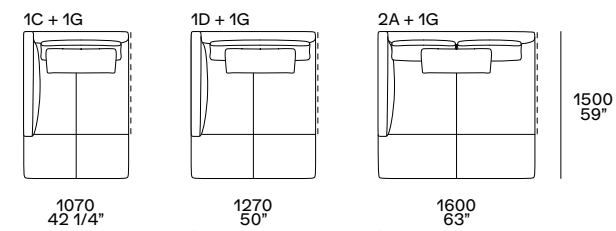

uso centrostanza o terminale  
 freestanding or end unit

**Day Bed**  
**Day Bed**

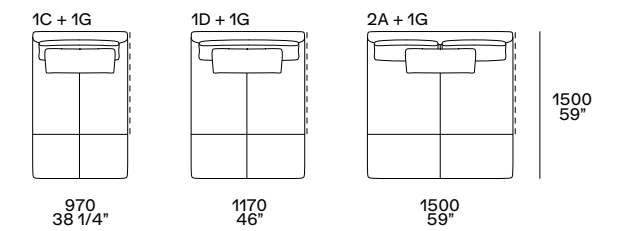

uso centrostanza, terminale o centrale  
 freestanding, end unit or central unit

**Pouf terminale sx-dx**  
**Lt-rt end unit pouf**

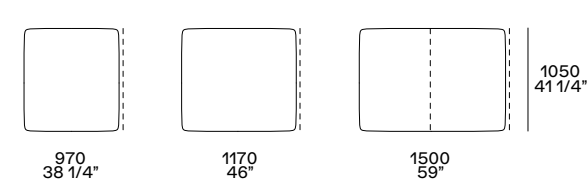

**Pouf angolo sx-dx**  
**Lt-rt corner pouf**

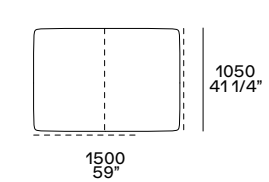

**Pouf centrale**  
**Central unit pouf**

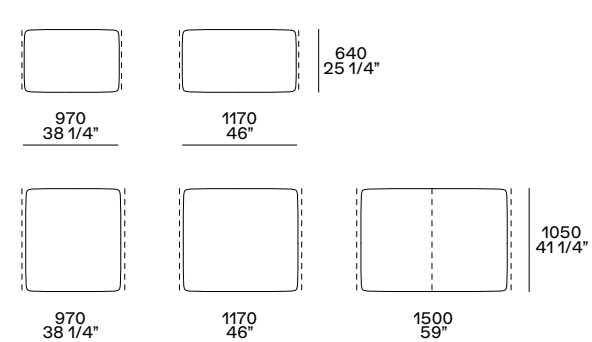

Si consiglia l'utilizzo del seguente schema per un perfetto comfort nell'utilizzo del divano.  
 Poliform suggests to follow this cushion combination to grant the perfect comfort of the sofa.

**Bristol cuscineria singola o doppia**  
**Bristol single or double backrest cushion**

**Cuscini schienale**  
**Backrest cushions**

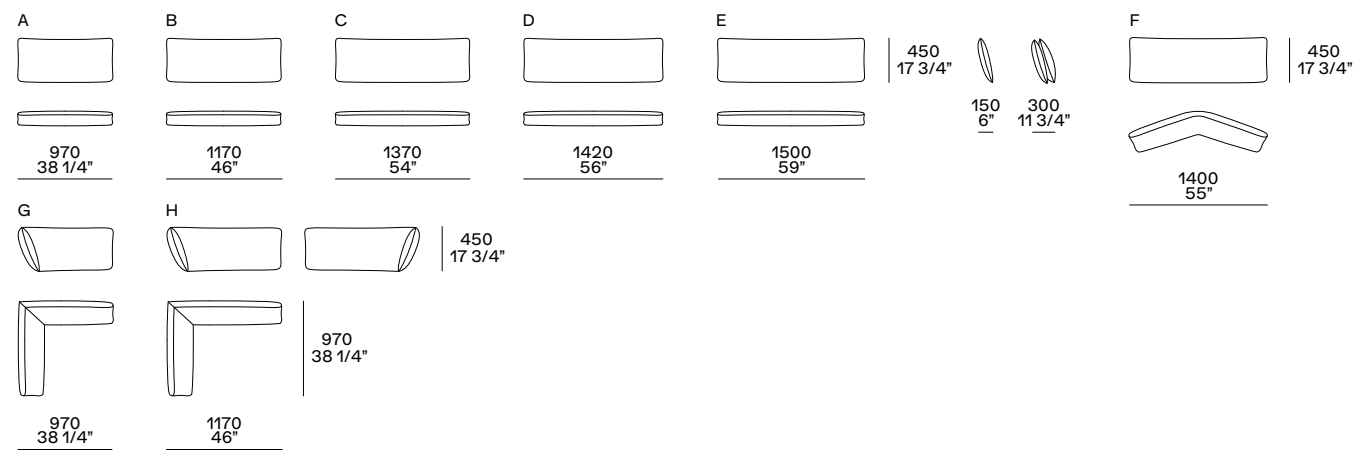

**Divano**  
**Sofa**

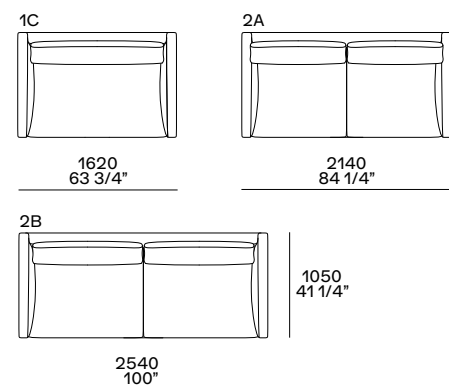

**Terminale sx-dx**  
**Lt-rt end unit**

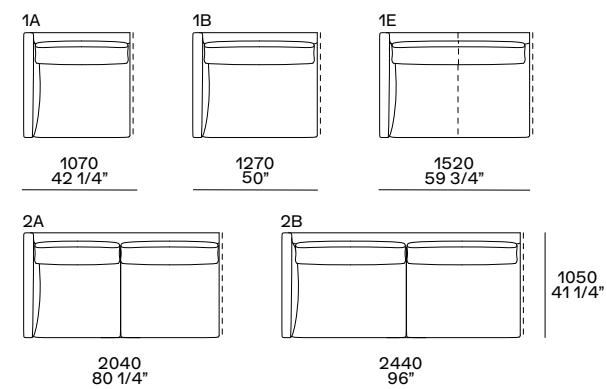

**Terminale senza bracciolo sx-dx**  
**Lt-rt end unit whitout arm**

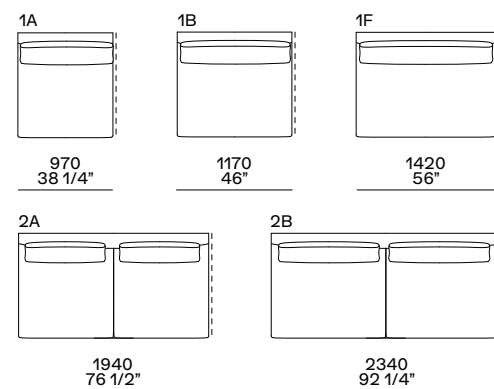

**Centrale**  
**Central unit**

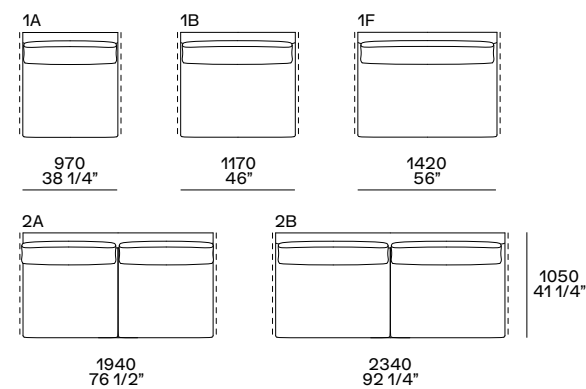

**Elemento inclinato**  
**Angled unit**

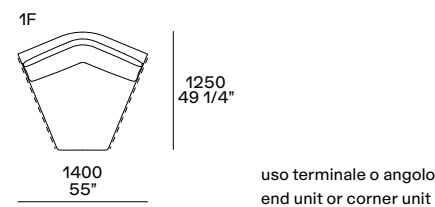

**Elemento inclinato pouf**  
**Angled unit pouf**

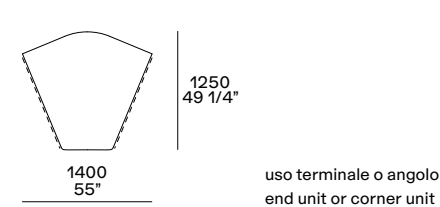

**Angolo sx-dx**  
**Lt-rt corner unit**

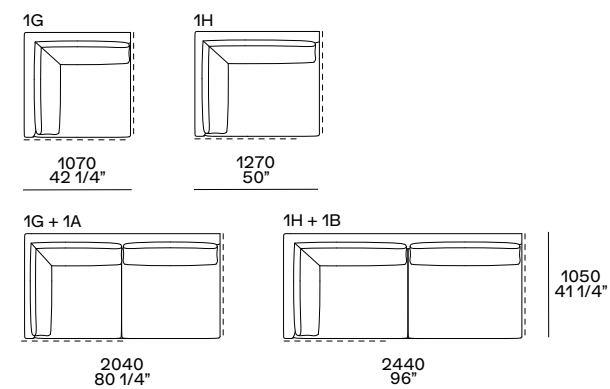

**Terminale angolo sx-dx**  
**Lt-rt corner end unit**

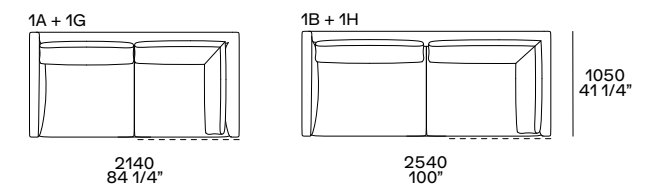

**Chaise longue**  
**Chaise longue**

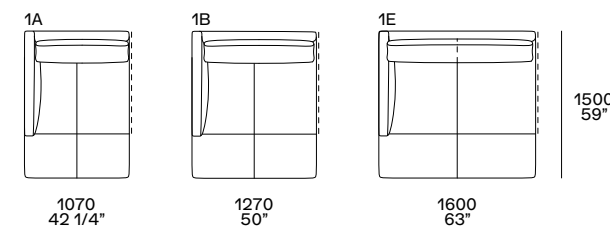

uso centrostanza o terminale  
 freestanding or end unit

**Day Bed**  
**Day Bed**

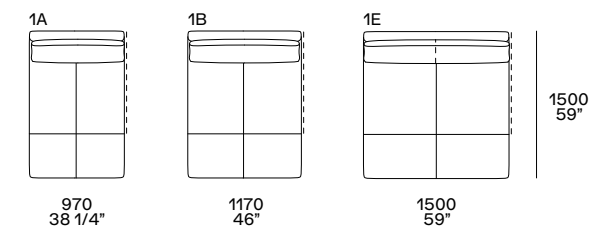

uso centrostanza, terminale o centrale  
 freestanding, end unit or central unit

**Pouf terminale sx-dx**  
**Lt-rt end unit pouf**

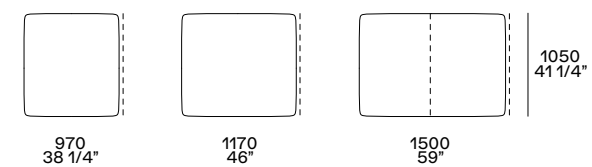

**Pouf angolo sx-dx**  
**Lt-rt corner pouf**

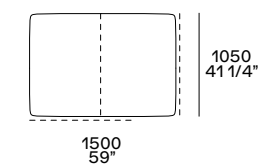

**Pouf centrale**  
**Central unit pouf**

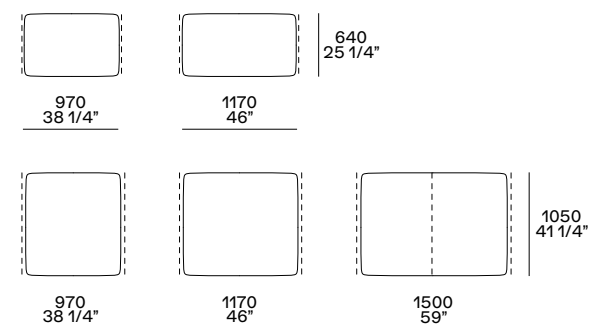

Si consiglia l'utilizzo del seguente schema per un perfetto comfort nell'utilizzo del divano.  
 Poliform suggests to follow this cushion combination to grant the perfect comfort of the sofa.

**Bristol cuscineria libera**  
Bristol loose cushions

**Cuscini**  
Cushions

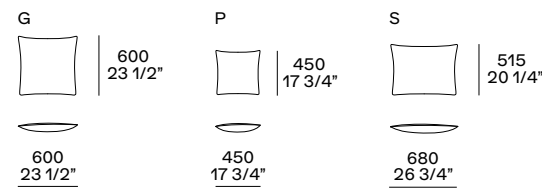

**Divano**  
Sofa

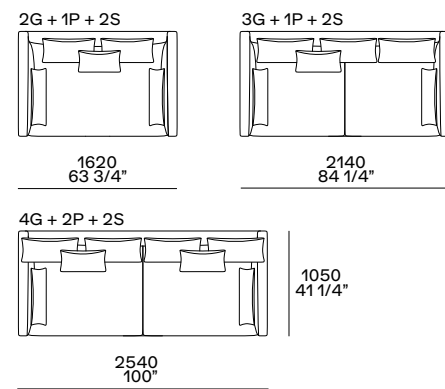

**Terminale sx-dx**  
Lt-rt end unit

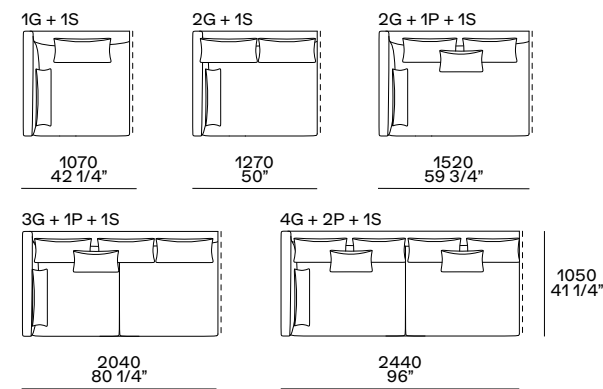

**Terminale senza bracciolo sx-dx**  
Lt-rt end unit whitout arm

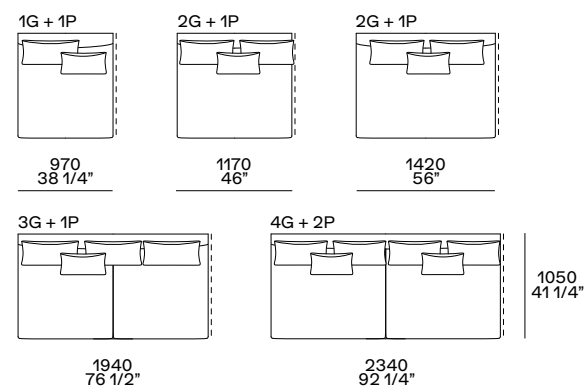

**Centrale**  
Central unit

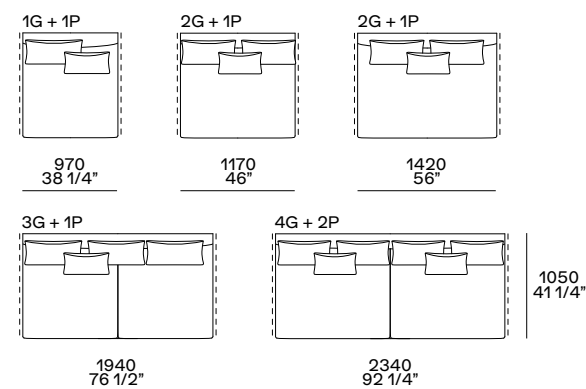

**Angolo sx-dx**  
Lt-rt corner unit

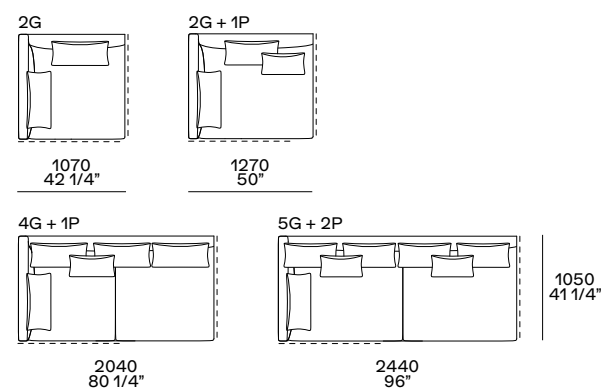

**Terminale angolo sx-dx**  
Lt-rt corner end unit

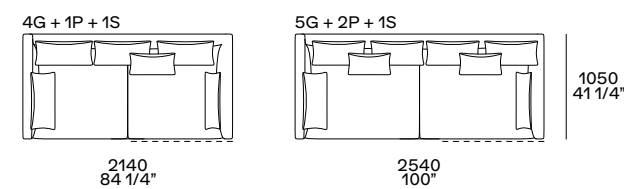

**Elemento inclinato**  
Angled unit

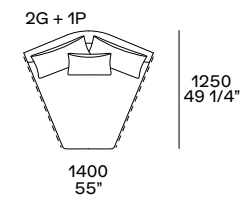

uso terminale o angolo  
end unit or corner unit

**Elemento inclinato pouf**  
Angled unit pouf

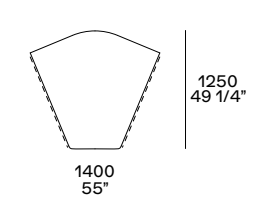

uso terminale o angolo  
end unit or corner unit

**Chaise longue**  
Chaise longue

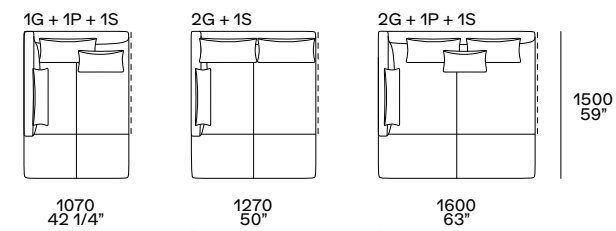

uso centrostanza o terminale  
freestanding or end unit

**Day Bed**  
Day Bed

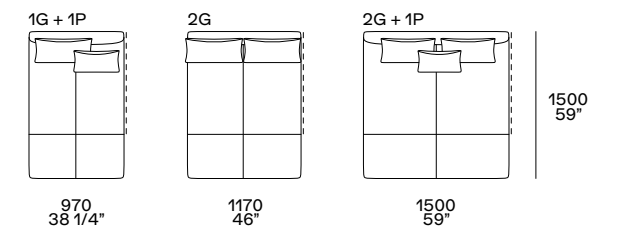

uso centrostanza, terminale o centrale  
freestanding, end unit or central unit

**Pouf terminale sx-dx**  
Lt-rt end unit pouf

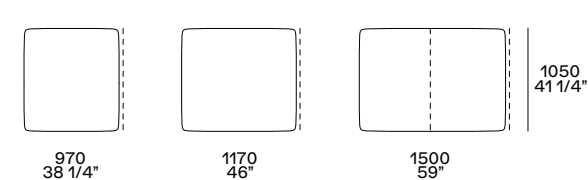

**Pouf angolo sx-dx**  
Lt-rt corner pouf

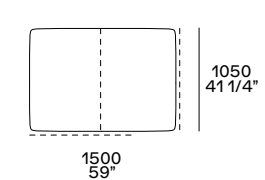

**Pouf centrale**  
Central unit pouf

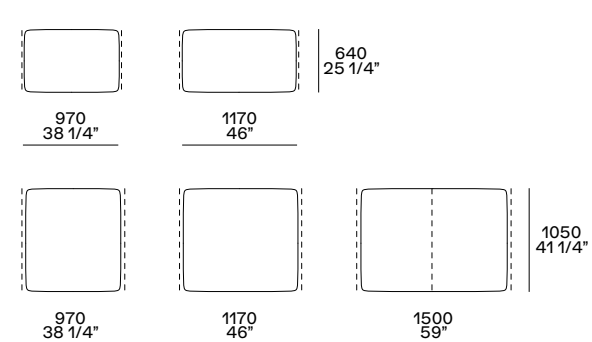

Si consiglia l'utilizzo del seguente schema per un perfetto comfort nell'utilizzo del divano.  
Poliform suggests to follow this cushion combination to grant the perfect comfort of the sofa.

## BRISTOL SYSTEM

Design Jean-Marie Massaud, 2013-2021

Serie di tavolini centrostanza e retrodivano o da affiancare lateralmente al divano, attrezzabili con una serie di contenitori. Tavolini centrostanza con piani in laccato opaco colori, rovere spessart o olmo nero. Piano superiore disponibile anche in cinque marmi levigati e lucidi (escluso emperador dark e sahara noir). Inserti e piedini in metallo verniciato brown nickel opaco o lucido. Tavolini retrodivano con struttura in laccato opaco colori, rovere spessart o olmo nero. Inserti e piedini in alluminio verniciato brown nickel opaco o lucido. Contenitori in laccato opaco colori, rovere spessart o olmo nero.

Series of coffee tables for central use and coffee tables to the back of the sofa or side tables, accessorized with different storage units. Coffee tables for central use with shelves in mat lacquered colours, spessart oak or black elm. Top shelf available also in five mat and glossy marbles (except emperador dark and sahara noir). Inlays and feet in mat or glossy brown nickel painted metal. Coffee tables at the back of the sofa with structure available in mat lacquered colours, spessart oak or black elm. Inlays and feet in mat or glossy brown nickel painted aluminium. Storage units in mat lacquered colours, spessart oak or black elm.

### Elemento retro divano Element to be placed at the back of the sofa

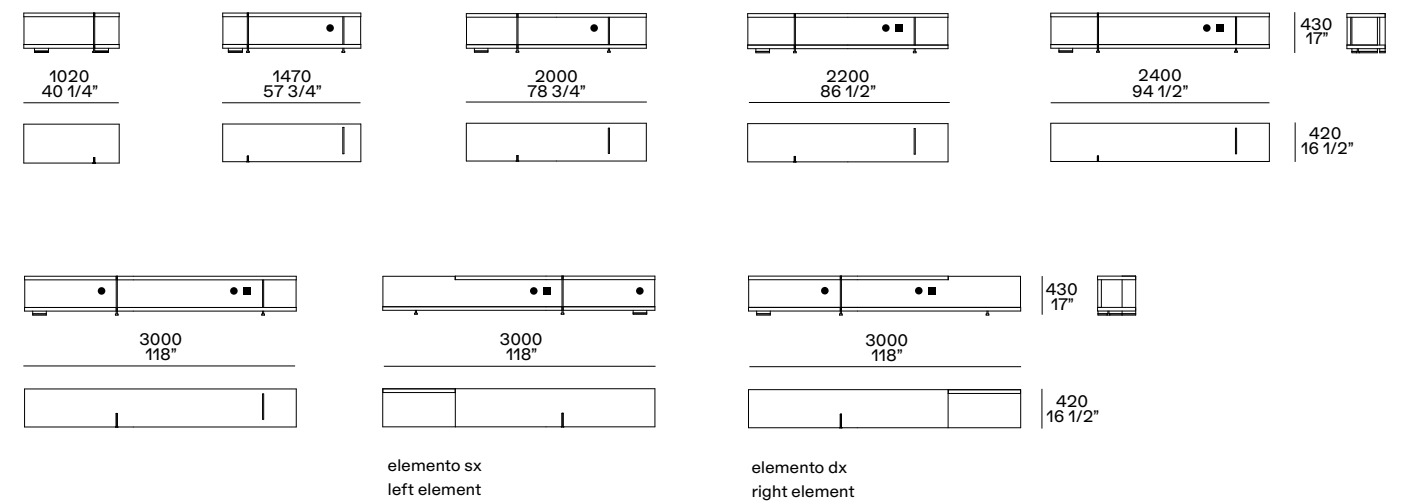

### Contenitore anta ribalta o cassetto Storage unit flap door or drawer

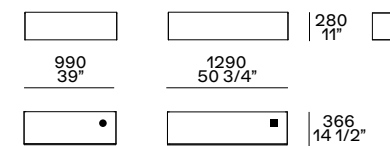

### Tavolino centrostanza Freestanding coffee table

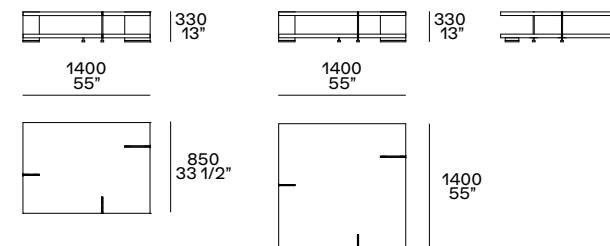

#### NB

È sconsigliato per motivi di allineamento l'utilizzo degli elementi retro divano Bristol System con divano Bristol h 680.

The use of Bristol System furniture is not recommended with Bristol sofa h 26 3/4" for alignment reasons.

# MONDRIAN

Un design essenziale, un'immagine grafica e moderna dalla forte valenza architettonica. Mondrian è un sistema pensato per offrire la massima libertà compositiva. I caratteristici piedini sottili in metallo sostengono una struttura lineare che sembra sospesa. Due le profondità di seduta disponibili e quattro le dimensioni dei braccioli, da arricchire con schienale in legno e mensole, o con il tavolino in essenza. Un progetto completo che interpreta con personalità il living contemporaneo.

A minimalistic design, a graphic and modern image with a strong architectural component. Mondrian is a system designed to offer maximum compositional freedom. The characteristic thin metal feet support a linear structure that seems suspended. Two seat depths available and armrests in four sizes, to be enriched with wooden backrest and shelves, or with the wooden coffee table. A complete project that interprets the contemporary living space with personality.







Qui e nelle pagine precedenti: divano Mondrian in tessuto sfoderabile Kitami 11 oceano, cuscini in tessuto Sendai 05 navy e Naxos 16 sabbia, tavolino integrato in olmo nero e piedini in brown nickel opaco. Tavolino Bristol piano in marmo calacatta oro levigato e in olmo nero, inserti e piedini in brown nickel opaco. Tavolino Paris Seoul in cuoio 02 nero e interno struttura in brown nickel opaco. Tavolino Mondrian struttura in brown nickel opaco e piano laccato opaco roccia. Poltrone Stanford con rivestimento non sfoderabile, esterno in cuoio 26 invecchiato, interno e cuscino della seduta in pelle Soft 04 cognac, basamento girevole in brown nickel lucido. Panca Home Hotel struttura in olmo nero e seduta rivestita in cordatura di pelle testa di moro. Tappeto Plain tortora.

This and previous pages: Mondrian sofa in removable fabric Kitami 11 oceano, cushions in fabric Sendai 05 navy and Naxos 16 sabbia, integrated coffee table in black elm and mat brown nickel feet. Bristol coffee table with top in mat marble calacatta oro and in black elm, inlays and feet in mat brown nickel. Paris Seoul coffee table in hide 02 nero and inner structure in mat brown nickel. Mondrian coffee table with mat brown nickel structure and roccia mat lacquered top. Stanford armchairs with non-removable cover, outer cover in hide 26 invecchiato, inner cover and seat cushion in leather Soft 04 cognac, swivel base in glossy brown nickel. Home Hotel bench with black elm structure and seat covered in stringed dark brown leather. Carpet Plain tortora.







Qui e nella pagina precedente: divano Mondrian ad angolo, rivestimento sfoderabile in velluto Glasgow 02 tortora, tavolino ad angolo con piano in olmo nero, cuscini in tessuto Agadir 04 tortora, velluto Glasgow 02 tortora e tessuto Agadir 04 tortora con inserto a croce Persia carbone, piedini in champagne opaco. A sinistra: dettaglio del tavolino ad angolo con struttura rivestita in velluto sfoderabile Glasgow 02 tortora e piano in olmo nero. Sotto: dettaglio del piano attrezzato con due prese usb.

This and previous page: Mondrian corner sofa, removable cover in velvet Glasgow 02 tortora, corner coffee table with top in black elm, cushions in fabric Agadir 04 tortora, velvet Glasgow 02 tortora and fabric Agadir 04 tortora with cross insert Persia carbone, mat champagne feet. Left: close up of the corner coffee table with structure covered in removable velvet Glasgow 02 tortora and top in black elm. Below: close up of the top accessorized with two usb sockets.

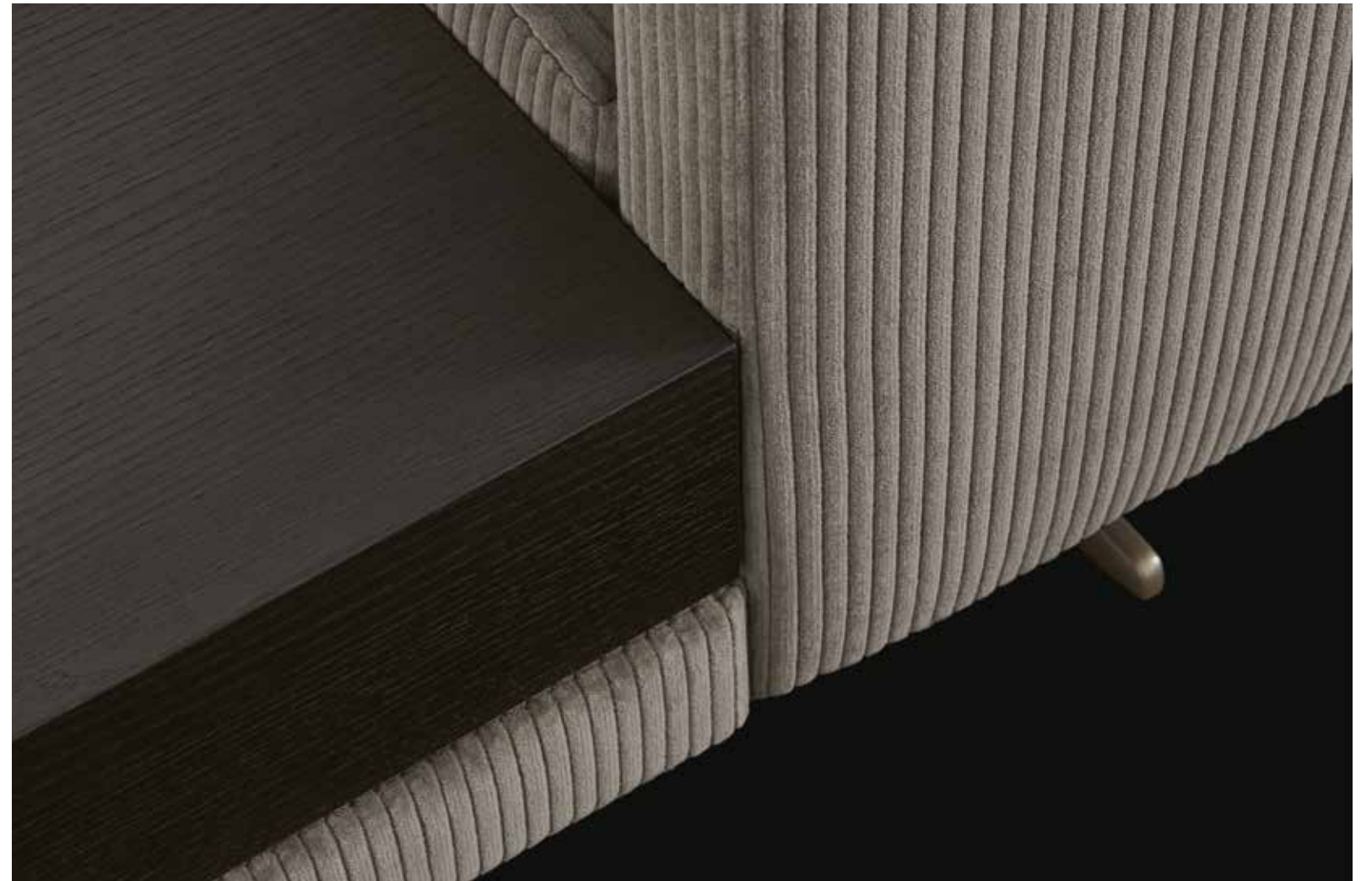





Qui e nella pagina precedente: divano Mondrian ad angolo con poggiatesta, rivestimento sfoderabile in tessuto Brest 02 salvia, cuscini in velluto Persia 1404 carbone e tessuto Brest 02 salvia con inserto a croce Persia carbone, tavolino integrato in noce gold e piedini in brown nickel lucido. In questa pagina: dettagli del tavolino integrato con cassetto in noce gold e maniglia in cuoio 02 nero.

This and previous page: Mondrian corner sofa with headrest, removable cover in fabric Brest 02 salvia, cushions in velvet Persia 1404 carbone and fabric Brest 02 salvia with cross insert Persia carbone, integrated coffee table in gold walnut and glossy brown nickel feet. This page: close up of the integrated coffee table with drawer in gold walnut and handle in hide 02 nero.





Qui e nella pagina precedente: divano Mondrian in tessuto sfoderabile Olimpia 11 polvere, cuscini in velluto Persia 1404 carbone e tessuto Olimpia 11 polvere con inserto a croce Persia carbone, tavolino integrato e schienale in legno con mensole in olmo nero, piedini in brown nickel lucido. Pouf Mondrian in velluto sfoderabile Persia 1404 carbone. Tavolini Mondrian struttura in fusione di bronzo lucidata oro, piani in marmo noir saint laurent lucido e laccato lucido caramello. Poltrone Stanford con rivestimento non sfoderabile, esterno in cuoio 26 invecchiato, interno in pelle Soft 04 cognac, basamento girevole in brown nickel lucido. Tappeto Frame grey.

This and previous page: Mondrian sofa in removable fabric Olimpia 11 polvere, cushions in velvet Persia 1404 carbone and fabric Olimpia 11 polvere with cross insert in Persia carbone, integrated coffee table and backrest in wood with shelves in black elm, feet in glossy brown nickel. Next page: Mondrian pouf in removable velvet Persia 1404 carbone. Mondrian coffee tables with structure in gold polishes bronze casting, tops in glossy marble noir saint laurent and caramello glossy lacquer. Stanford armchairs with non-removable cover, outer cover in hide 26 invecchiato, inner cover in leather Soft 04 cognac, and swivel base in glossy brown nickel. Carpet Frame grey.







Qui e nella pagina precedente: divano Mondrian ad angolo in tessuto sfoderabile Kitami 07 roccia, lato pouf terminale nella profondità 1250. Cuscini in velluto Persia 1404 carbone e tessuto Kitami 07 roccia con inserto a croce Persia carbone, tavolino integrato in olmo nero e piedini in brown nickel lucido. A sinistra: dettaglio del cuscino schienale con rullo. Sotto: dettaglio del poggiatesta con struttura rivestita in cuoio 03 grigio scuro. Nella pagina successiva: divano Mondrian in pelle sfoderabile Soft 10 prugna, cuscini in velluto Persia 2006 prugna e tessuto Olimpia 112 prugna, tavolino integrato in olmo nero e piedini in brown nickel opaco.

This and previous page: Mondrian corner sofa in removable fabric Kitami 07 roccia, side with pouf as end unit depth 49 1/4". Cushions in velvet Persia 1404 carbone and fabric Kitami 07 roccia with cross insert in Persia carbone, integrated coffee table in black elm and glossy brown nickel feet. Left: close up of the backrest cushion with roll. Below: close up of the headrest with structure covered in hide 03 grigio scuro. Next page: Mondrian sofa in removable leather Soft 10 prugna, cushions in velvet Persia 2006 prugna and fabric Olimpia 112 prugna, integrated coffee table in black elm and mat brown nickel feet.









Nella pagina precedente: divano Mondrian in pelle sfoderabile Soft 10 prugna, cuscini in tessuto Olimpia 112 prugna, tavolino integrato in olmo nero e piedini in brown nickel opaco. Tavolini Mondrian con struttura in brown nickel lucido e piani in olmo nero e laccato lucido ocra; con struttura in fusione di bronzo lucidata oro e piano in marmo calacatta oro levigato. Poltrone Marlon Lounge in tessuto sfoderabile Sparta 16 ferro, gambe in olmo nero. In questa pagina: chaise longue Mondrian in pelle sfoderabile Soft 02 mastice, cuscino in tessuto Naxos 16 sabbia, tavolino integrato con cassetto in rovere spessart e maniglia in cuoio 02 nero, piedini in brown nickel opaco. Nella successiva: divano Mondrian in tessuto sfoderabile Naxos 32 bordeaux, poggiatesta con struttura rivestita in cuoio 15 prugna, piedini in brown nickel opaco.

Previous page: Mondrian sofa in removable leather Soft 10 prugna, cushions in fabric Olimpia 112 prugna, integrated coffee table in black elm and mat brown nickel feet. Mondrian coffee tables with structure in glossy brown nickel and tops in black elm and in ocra glossy lacquer; with structure in gold polished bronze casting and top in mat marble calacatta oro. Marlon Lounge armchairs in removable fabric Sparta 16 ferro, legs in black elm. This page: Mondrian chaise longue in removable leather Soft 02 mastice, cushion in fabric Naxos 16 sabbia, integrated coffee table with drawer in spessart oak and handle in hide 02 nero, feet in mat brown nickel. Next page: Mondrian sofa in removable fabric Naxos 32 bordeaux, headrest cushion with structure covered in hide 15 prugna, mat brown nickel feet.







In questa pagina: pouf Mondrian in pelle sfoderabile Nabuk 04 moka, tavolino integrato in olmo nero e piedini in brown nickel lucido. Nella successiva: divano Mondrian in tessuto sfoderabile Sparta 18 panna, cuscini in tessuto Sparta 15 ardesia e 18 panna con inserto a croce Persia carbone, piedini in brown nickel lucido. Tavolini e consolle Mondrian con struttura in fusione di bronzo lucidata oro e piani in marmo noir saint laurent lucido e laccato lucido visone. Poltrone Mad Joker rivestimento non sfoderabile, esterno in pelle Nabuk 02 tortora e interno tessuto Sheffield 03 tortora, basamento girevole in brown nickel lucido. Tappeto Soft.

This page: Mondrian pouf in removable leather Nabuk 04 moka, integrated coffee table in black elm and glossy brown nickel feet. Next page: Mondrian sofa in removable fabric Sparta 18 panna, cushions in fabric Sparta 15 ardesia and 18 panna with cross insert in Persia carbone, glossy brown nickel feet. Mondrian coffee tables and console with structure in gold polished bronze casting and top in glossy marble noir saint and visone glossy lacquer. Mad Joker armchairs with non-removable cover, outer cover in leather Nabuk 02 tortora and inner cover in fabric Sheffield 03 tortora, swivel base in glossy brown nickel. Carpet Soft.





## MONDRIAN

Design Jean-Marie Massaud, 2016

Struttura in poliuretano flessibile stampato, prerivestimento in fibra di poliestere accoppiata. Schienale in legno con mensola e tavolino integrato in legno e derivati, impiallacciati in olmo nero, rovere spessart o noce gold. Cuscino seduta in poliuretano flessibile sagomato a quote differenziate, prerivestimento in tela cotone e piuma con parti in fibra di poliestere accoppiata. Cuscino schienale con rullo in poliuretano flessibile sagomato a quote differenziate, prerivestimento parti in tela cotone con interni in piuma e parti in fibra di poliestere accoppiata. Kit cuscini schienale: coppia di cuscini utilizzabili in alternativa al cuscino schienale con rullo; 500x500 parti in tela cotone e piuma, 550x550 parti in tela cotone e piuma con interno in poliuretano flessibile sagomato. L'utilizzo del kit cuscini al posto del cuscino schienale con rullo è consigliato soprattutto negli elementi angolari. Poggiatesta opzionale con cuscino in poliuretano flessibile sagomato, rivestimento sfoderabile in tessuto o pelle, struttura in metallo rivestito in cuoio colori. Piedini in fusione di alluminio verniciato in brown nickel opaco e lucido o champagne opaco. Rivestimento sfoderabile in tessuto o pelle.

Structure in flexible moulded polyurethane, pre-cover in coupled polyester fibre. Back in wood with integrated shelf and coffee table in wood and wood-by products, veneered in black elm, spessart oak or gold walnut. Seat cushion in flexible shaped multi-density polyurethane, pre-cover in cotton canvas and down with parts in coupled polyester fibre. Backrest cushion with roll in flexible shaped multi-density polyurethane, pre-cover with parts in cotton canvas with down inside and parts in coupled polyester fibre. Backrest cushions-kit: pair of cushions, which can be used as an alternative to the backrest cushion with roll; 19 3/4"x19 3/4" with parts in cotton canvas and down, 21 3/4"x21 3/4" with parts in cotton canvas and down with flexible shaped polyurethane inside. The cushions kit instead of the backrest cushion with roll is recommended especially in the corner elements. Optional headrest with cushion in flexible shaped polyurethane, removable cover in fabric or leather, structure in metal covered in hide in the available colours. Feet in aluminium-casting painted mat and glossy brown nickel or mat champagne. Removable cover in fabric or leather.

### Tipologie bracciolo con schienale tessuto o pelle Arm types with fabric or leather back



bracciolo I 75  
arm w 3"



bracciolo I 200  
arm w 7 3/4"



bracciolo I 400  
arm w 15 3/4"



tavolino I 400  
coffee table w 15 3/4"

### Tipologie bracciolo con schienale legno e mensole Arm types with wooden back and shelves



bracciolo I 75  
arm w 3"



bracciolo I 200  
arm w 7 3/4"



bracciolo I 400  
arm w 15 3/4"



tavolino I 400  
coffee table w 15 3/4"

### Tipologie componenti, profondità 950 Components typology, depth 37 1/2"

bracciolo I 75  
arm w 3"

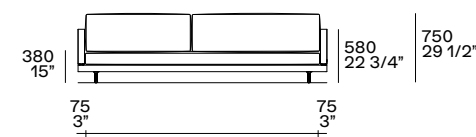

schienale tessuto o pelle  
fabric or leather back

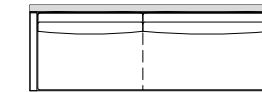

schienale legno con mensole  
wooden back with shelves

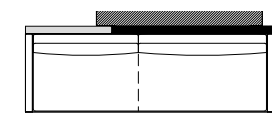

bracciolo I 200  
arm w 7 3/4"

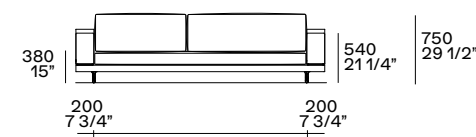

schienale tessuto o pelle  
fabric or leather back

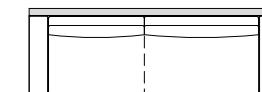

schienale legno con mensole  
wooden back with shelves

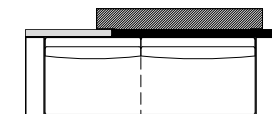

bracciolo I 400  
arm w 15 3/4"

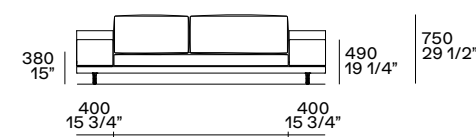

schienale tessuto o pelle  
fabric or leather back

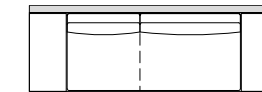

schienale legno con mensole  
wooden back with shelves

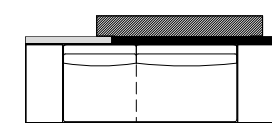

tavolino I 400 con cassetto opzionale  
coffee table w 15 3/4" with optional drawer

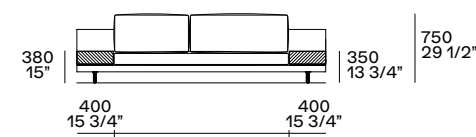

schienale tessuto o pelle  
fabric or leather back

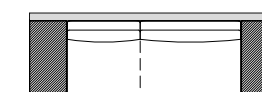

schienale legno con mensole  
wooden back with shelves

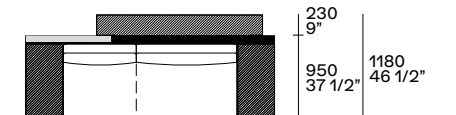

### Tipologie componenti, profondità 1250 Components typology, depth 49 1/4"

bracciolo I 200  
arm w 7 3/4"

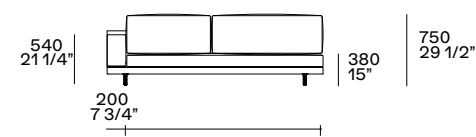

schienale tessuto o pelle  
fabric or leather back

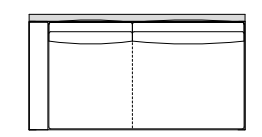

tavolino I 400 con cassetto  
coffee table w 15 3/4" with drawer

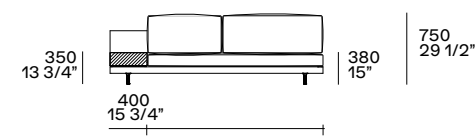

schienale tessuto o pelle  
fabric or leather back

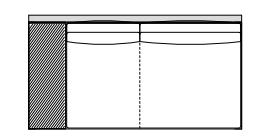

1250  
49 1/4"

**NB**  
Divano privo di giunzioni, liberamente aggregabile.  
Sofa without joints, allowing combination freedom.

**Modularità componenti, profondità 950**  
**Components modularity, depth 37 1/2"**

**Divani fissi**  
**Fixed sofas**

bracciolo l 75  
 arm w 3"

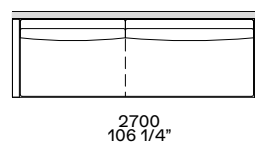
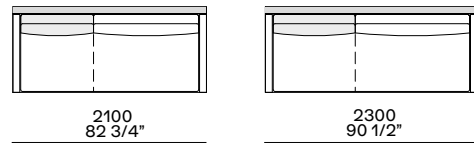

bracciolo l 200  
 arm w 7 3/4"

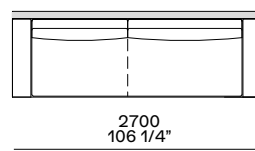
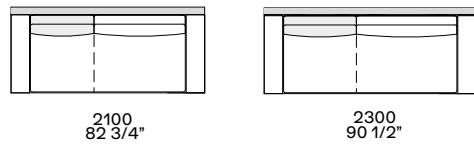

bracciolo l 200-400, sx-dx  
 arm w 7 3/4"-15 3/4", lt-rt

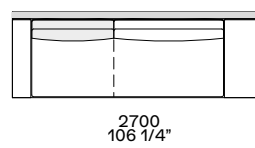
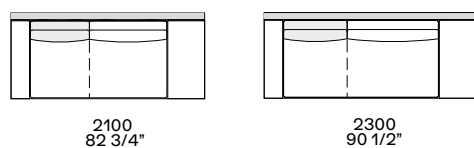

bracciolo l 400  
 arm w 15 3/4"

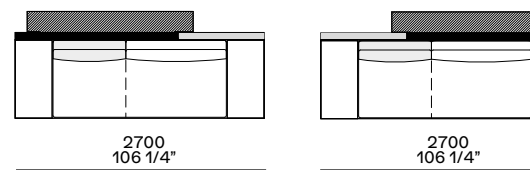
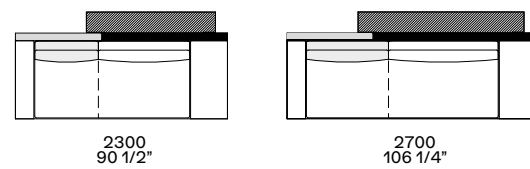
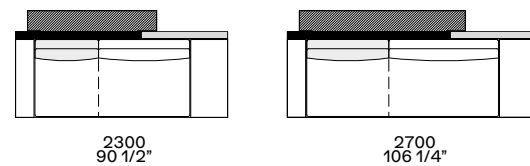
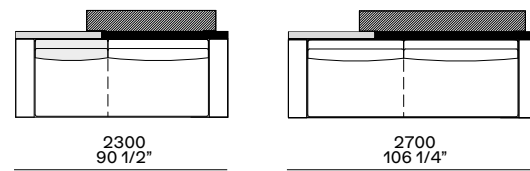
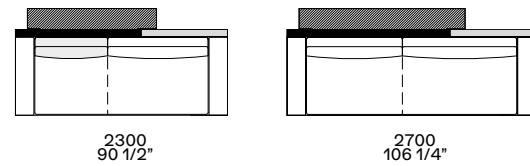
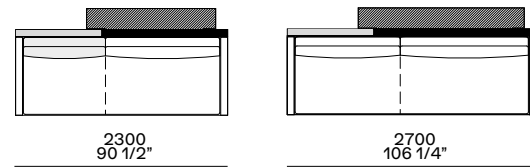
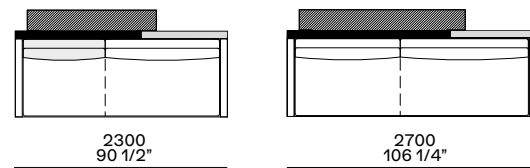
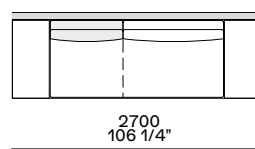

**Divani fissi**  
**Fixed sofas**

bracciolo l 200 e tavolino l 400, sx-dx  
 arm w 7 3/4" and coffee table w 15 3/4", lt-rt

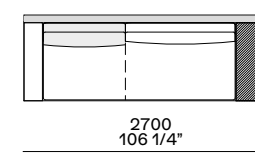
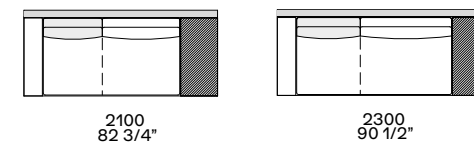

bracciolo l 400 e tavolino l 400, sx-dx  
 arm w 15 3/4" and coffee table w 15 3/4", lt-rt

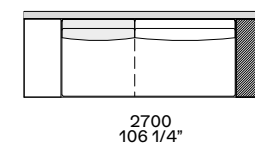

tavolini l 400  
 coffee tables w 15 3/4"

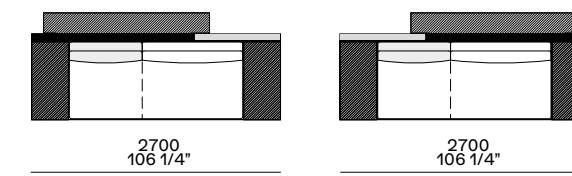
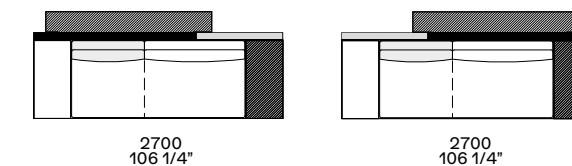
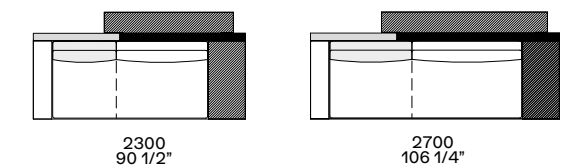
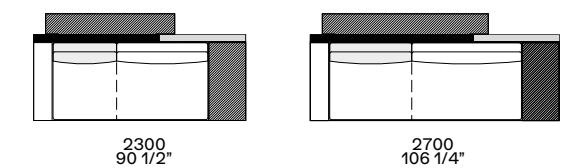
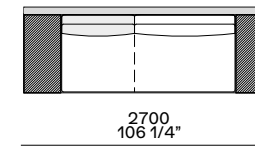

**Cuscini opzionali**  
**Optional cushions**

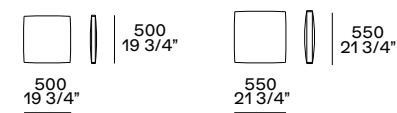

un kit è composto dai due cuscini  
 one kit is composed by the two cushions

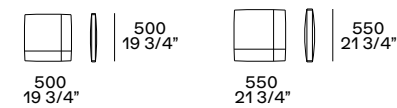

lavorazione a croce con inserto in velluto Persia  
 manufacturing with cross insert in velvet Persia

I cuscini schienale, evidenziati in grigio possono essere sostituiti con un kit cuscini.  
 The seat cushions indicated in grey can be replaced by a loose cushions kit.

**Poggiatesta**  
**Headrest**

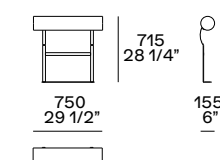

Utilizzabile esclusivamente in abbinamento al cuscino schienale con rullo, non utilizzabile con schienale con mensole.  
 It can be used only in combination with the backrest cushion with roll, it can not be used with wooden back with shelves.



**Modularità componenti, profondità 950**  
**Components modularity, depth 37 1/2"**

**Terminale sx-dx**  
**Lt-rt end unit**

bracciolo I 75  
 arm w 3"

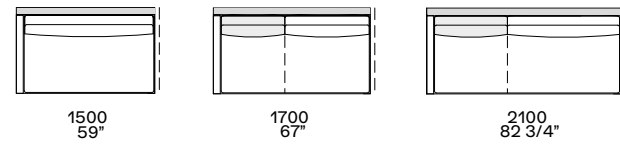

bracciolo I 200  
 arm w 7 3/4"

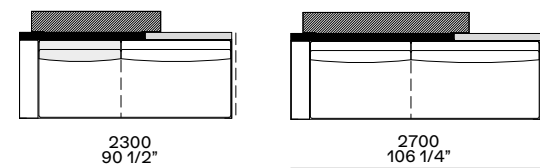
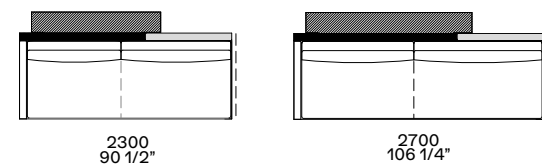
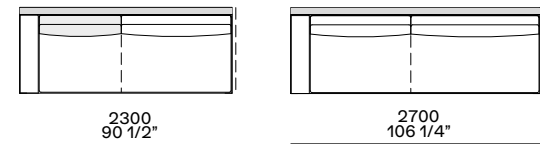
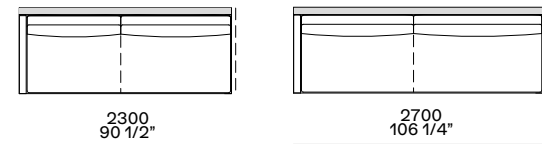
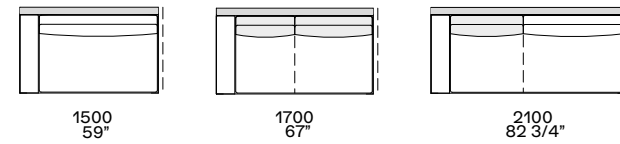

bracciolo I 75 e tavolino I 400  
 arm w 3" and coffee table w 15 3/4"

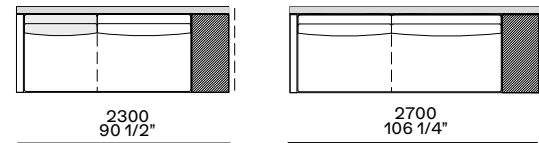

bracciolo I 200 e tavolino I 400  
 arm w 7 3/4" and coffee table w 15 3/4"

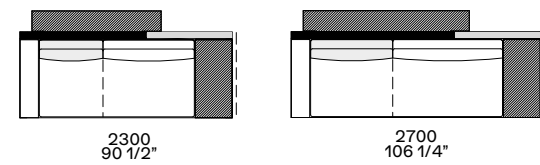
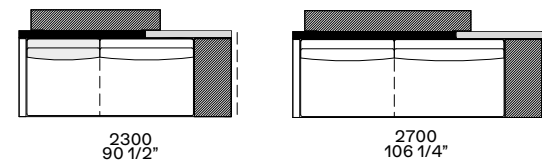
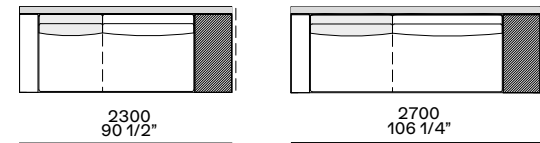

bracciolo I 400  
 arm w 15 3/4"

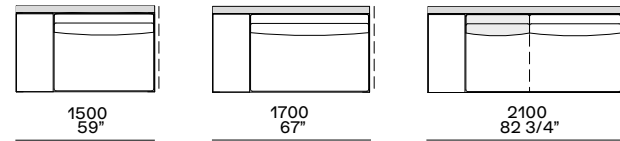

tavolino I 400  
 coffee table w 15 3/4"

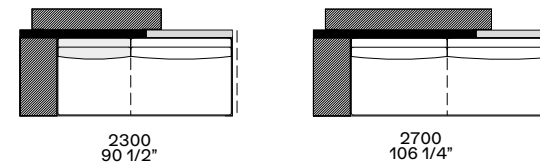
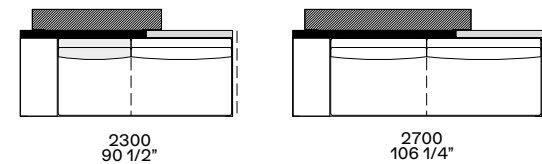
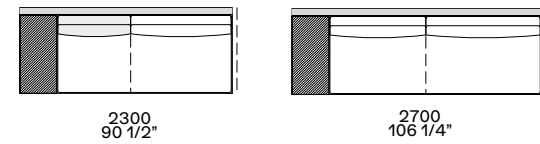
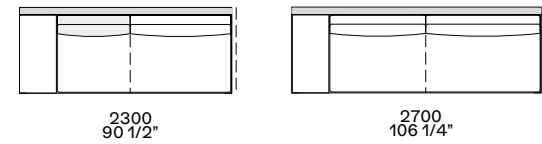
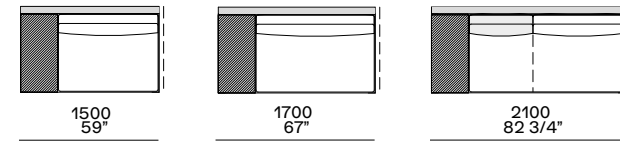

**Terminale sx-dx**  
**Lt-rt end unit**

bracciolo I 400 e tavolino I 400  
 arm w 15 3/4" and coffee table w 15 3/4"

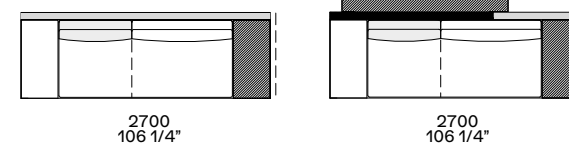

tavolini I 400  
 coffee tables w 15 3/4"

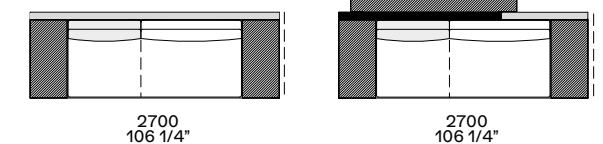

**Centrale**  
**Central unit**

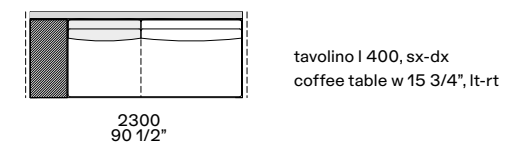
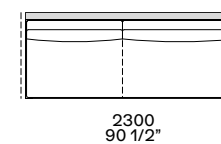
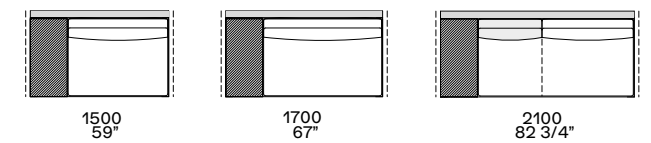
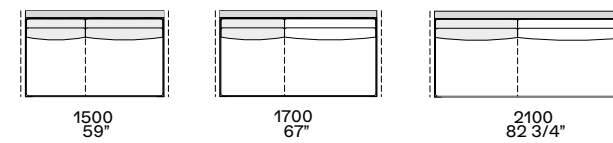

tavolino I 400, sx-dx  
 coffee table w 15 3/4", lt-rt

**Terminale penisola sx-dx**  
**Lt-rt peninsula end unit**

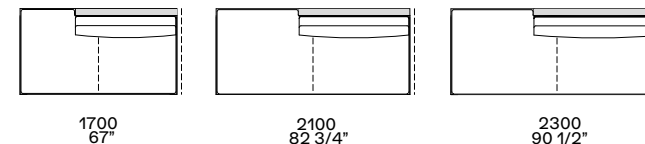

tavolino I 400  
 coffee table w 15 3/4"

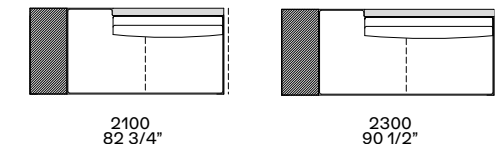

**Chaise longue**  
**Chaise longue**

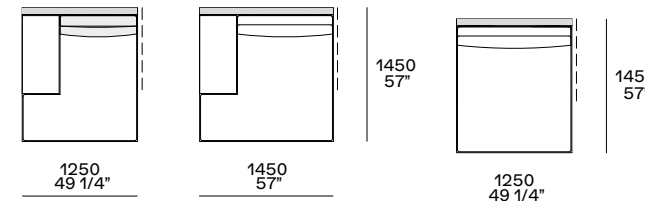

uso centrostanza o terminale  
 freestanding or end unit

uso centrostanza,  
 terminale o centrale  
 freestanding, end unit  
 or central unit

**Pouf**  
**Pouf**

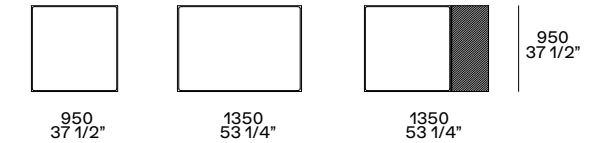

uso centrostanza, terminale, angolo o centrale  
 freestanding, end unit, corner or central unit

**Tavolino**  
**Coffee table**

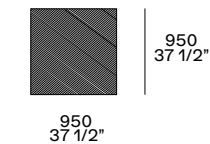

Utilizzabile solo ad angolo tra due elementi del divano,  
 attrezzabile con modulo di cablaggio in ardesia o  
 champagne, con una presa elettrica o due prese usb.  
 It can be used only in the corner between two sofa  
 elements, it can be accessorized with wiring module in  
 ardesia or champagne, with an electrical socket or two  
 usb sockets.

I cuscini schienale, evidenziati in grigio possono  
 essere sostituiti con un kit cuscini.  
 The seat cushions indicated in grey can be replaced  
 by a loose cushions kit.

**Modularità componenti, profondità 950**  
**Components modularity, depth 37 1/2"**

**Angolo sx-dx con cuscini schienale**  
**Lt-rt corner unit with backrest cushions**

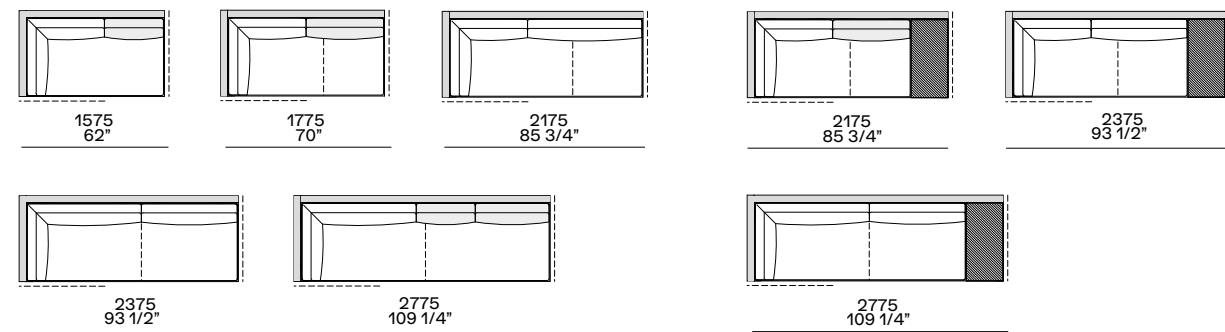

**Terminale angolo sx-dx con cuscini schienale**  
**Lt-rt corner end unit with backrest cushions**

bracciolo l 75  
arm w 3"

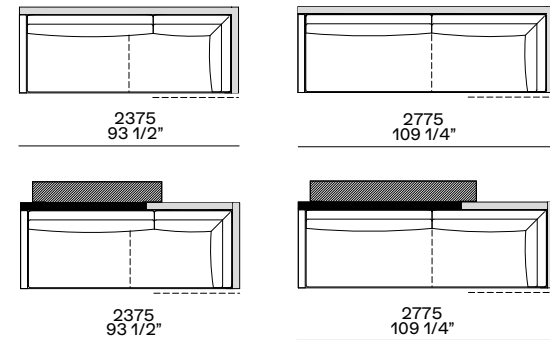

bracciolo l 200  
arm w 7 3/4"

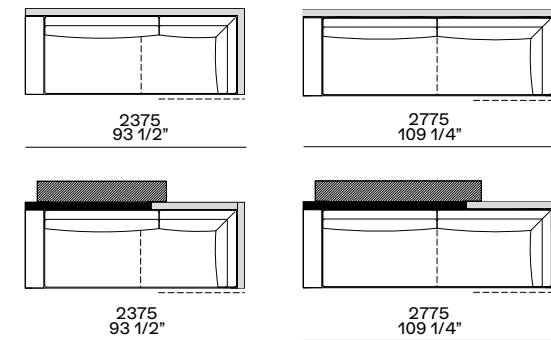

bracciolo l 400  
arm w 15 3/4"

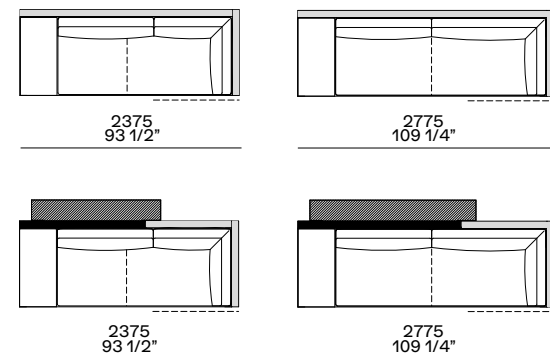

tavolino l 400  
coffee table w 15 3/4"

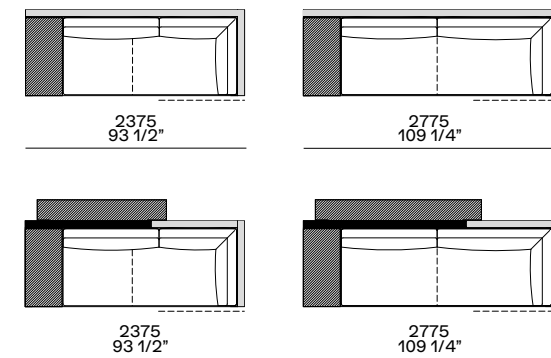

**Penisola, angolo penisola o divano chaise longue sx-dx con cuscini schienale**  
**Lt-rt peninsula, corner peninsula or chaise longue sofa with backrest cushions**

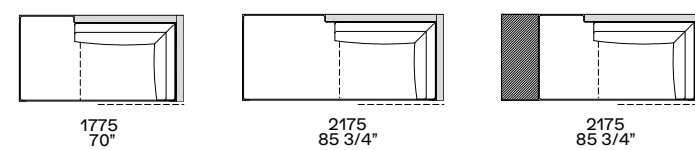

**Angolo sx-dx con kit cuscini**  
**Lt-rt corner unit with kit cushions**

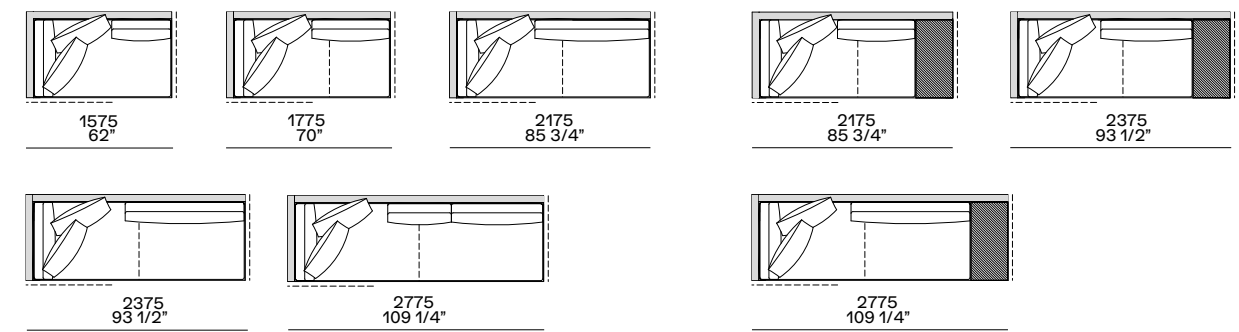

**Terminale angolo sx-dx con kit cuscini**  
**Lt-rt corner end unit with kit cushions**

bracciolo l 75  
arm w 3"

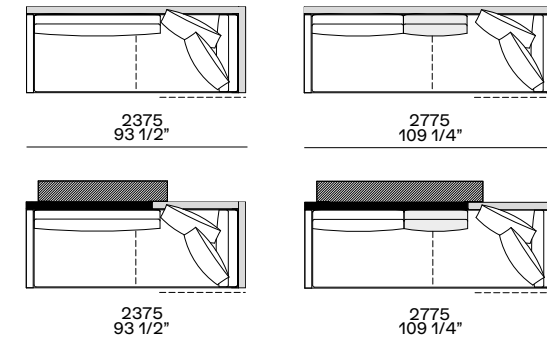

bracciolo l 200  
arm w 7 3/4"

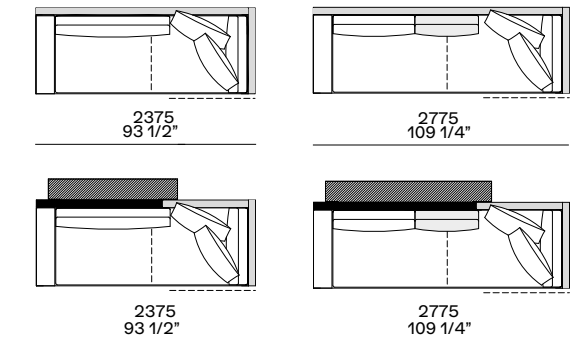

bracciolo l 400  
arm w 15 3/4"

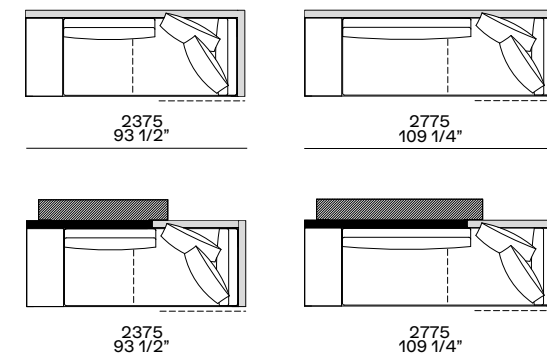

tavolino l 400  
coffee table w 15 3/4"

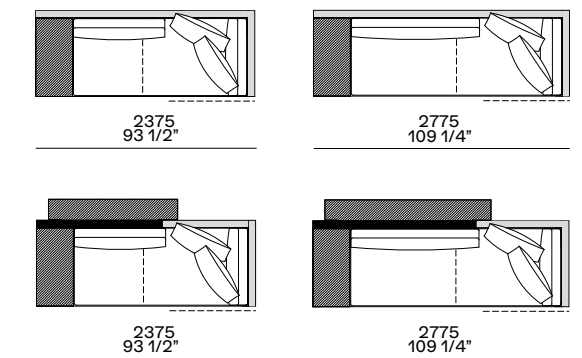

**Penisola, angolo penisola o divano chaise longue sx-dx con kit cuscini schienale**  
**Lt-rt peninsula, corner peninsula or chaise longue sofa with kit cushions**

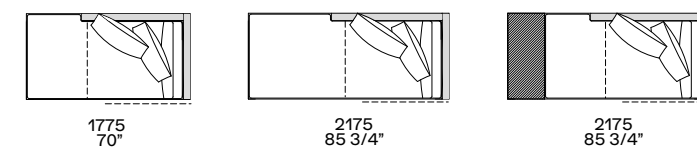

I cuscini schienale, evidenziati in grigio possono essere sostituiti con un kit cuscini.  
 The seat cushions indicated in grey can be replaced by a loose cushions kit.

**Modularità componenti, profondità 1250**  
**Components modularity, depth 49 1/4"**

**Terminale sx-dx**  
**Lt-rt end unit**

bracciolo l 200  
 arm w 7 3/4"

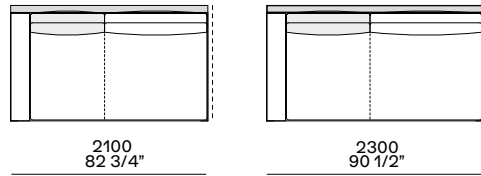

**Terminale sx-dx o centrale**  
**Lt-rt end unit or central unit**

tavolino l 400  
 coffee table w 15 3/4"

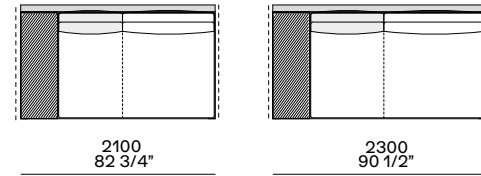

**Centrale**  
**Central unit**

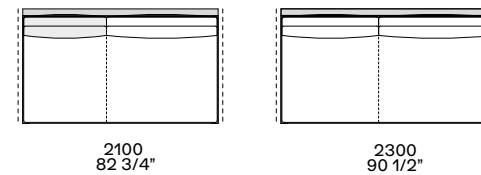

**Pouf**  
**Pouf**

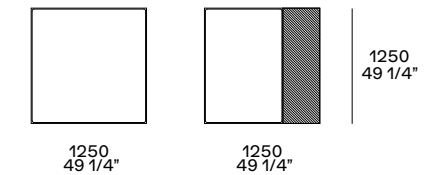

uso centrostanza, terminale o centrale  
 freestanding, end unit or central unit

**Terminale angolo sx-dx con cuscini schienale**  
**Lt-rt corner end unit with backrest cushions**

bracciolo l 200  
 arm w 7 3/4"

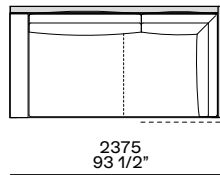

**Terminale angolo sx-dx con kit cuscini**  
**Lt-rt corner end unit with kit cushions**

bracciolo l 200  
 arm w 7 3/4"

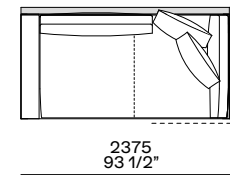

**Angolo sx-dx con cuscini schienale**  
**Lt-rt corner unit with backrest cushions**

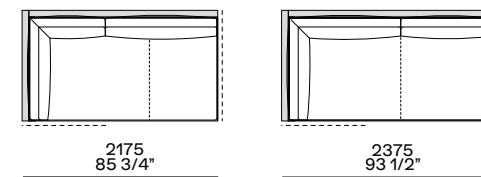

**Angolo sx-dx con kit cuscini**  
**Lt-rt corner unit with kit cushions**

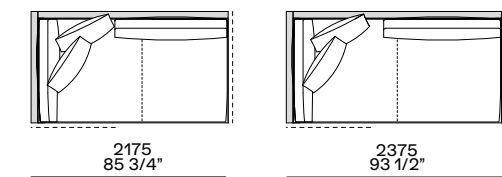

**Terminale angolo o angolo sx-dx con cuscini schienale**  
**Lt-rt corner end unit or corner unit with backrest cushions**

tavolino l 400  
 coffee table w 15 3/4"

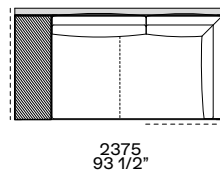

**Terminale angolo o angolo sx-dx con kit cuscini**  
**Lt-rt corner end unit or corner unit with kit cushions**

tavolino l 400  
 coffee table w 15 3/4"

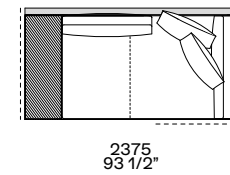

**Poggiatesta**  
**Headrest**

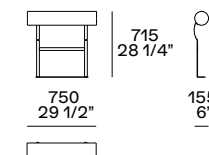

Utilizzabile esclusivamente in abbinamento al cuscino schienale con rullo, non utilizzabile con schienale con mensole.  
 It can be used only in combination with the backrest cushion with roll, it can not be used with wooden back with shelves.

I cuscini schienale, evidenziati in grigio possono essere sostituiti con un kit cuscini.  
 The seat cushions indicated in grey can be replaced by a loose cushions kit.



# WESTSIDE

Westside è un sistema multifunzionale che riscrive con eleganza l'esperienza della zona living. I moduli imbottiti si affiancano tra loro per creare le più diverse configurazioni – dall'isola bifacciale al classico divano angolare – mentre gli elementi come la chaise longue ergonomica, lo schienale mobile e i tavolini ne arricchiscono la funzionalità. Un archetipo di convivialità da vivere con la massima libertà.

Westside is a multifunctional system that elegantly rewrites the experience of the living area. The padded modules come together to create the most diverse configurations – from the two-face island to the classic corner sofa – while the elements such as the ergonomic chaise longue, the movable backrest, and the coffee tables enrich its functionality. An archetype of conviviality to be experienced with maximum freedom.







Qui e nelle pagine precedenti: divano Westside in tessuto sfoderabile Arcadia 02 sabbia, cuscini in velluto Tebe 06 giada, basamento in brown nickel opaco. Tavolini Westside, piano in marmo zecevo levigato e olmo nero, struttura in olmo nero e brown nickel opaco. Poltrona Kay Lounge in pelle non sfoderabile Hairy bianco/nero e struttura in cromo satinato. Madia Code in noce gold con top in laccato metallico bronzo, vano a giorno in laccato opaco bronzo e zoccolino in ardesia opaco. Mensolone Code retroilluminato in laccato opaco granata. Tappeto Tratto carbone. Sotto: dettaglio del cuscino schienale con poggiatesta in cuoio 26 invecchiato.

This and previous pages: Westside sofa in removable fabric Arcadia 02 sabbia, cushions in velvet Tebe 06 giada, base in mat brown nickel. Westside coffee tables, top in mat marble zecevo and black elm, structure in black elm and mat brown nickel. Kay Lounge armchair in non-removable Hairy leather white/black and structure in brushed chrome. Code sideboard in gold walnut with top in metal lacquer bronzo, open compartment in mat lacquer bronzo and plinth in mat ardesia. Code backlit thick shelf in granata mat lacquer. Carpet Tratto carbone. Below: close up of the backrest cushion with headrest in hide 26 invecchiato.

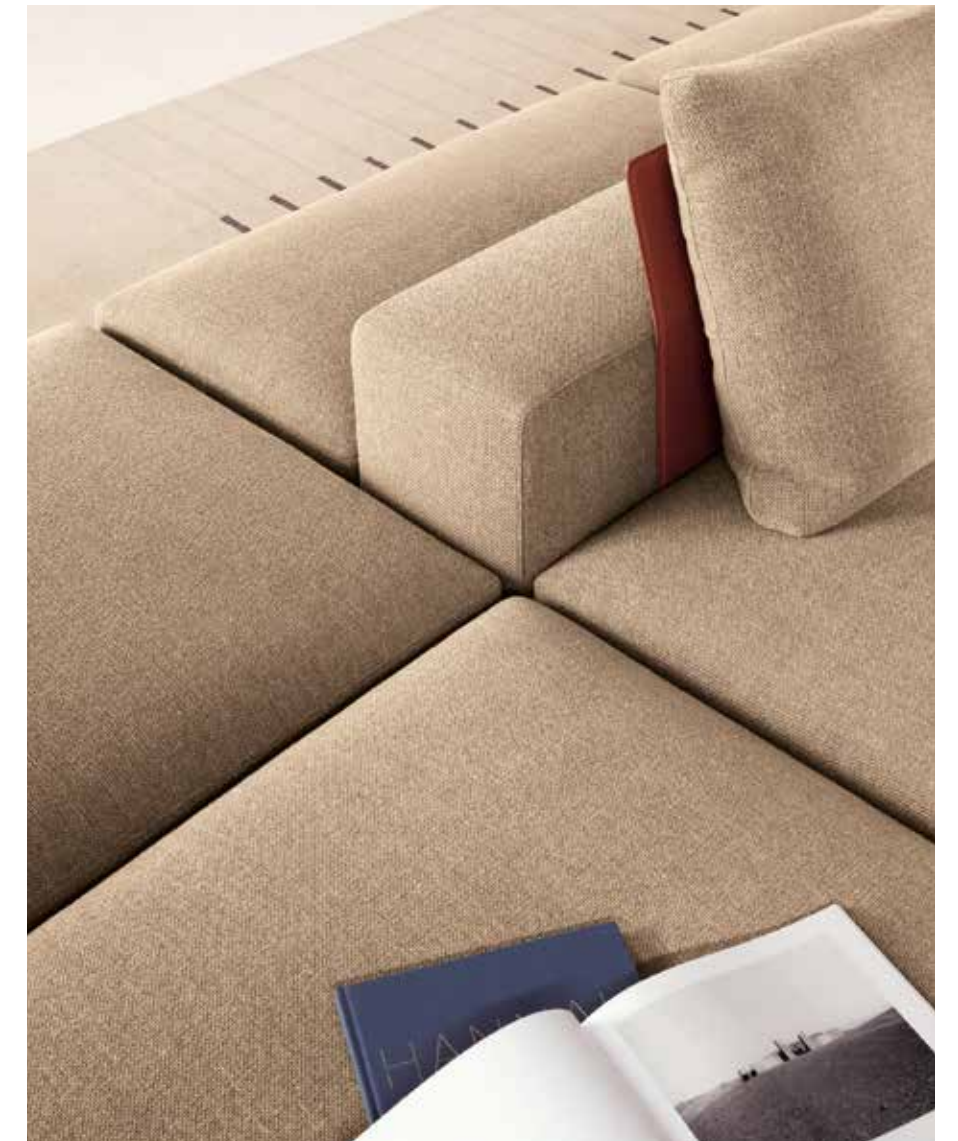

In questa pagina: pouf Westside con rivestimento sfoderabile in tessuto Arcadia 02 sabbia e schienale mobile in cuoio 26 invecchiato, basamento in brown nickel opaco.

This page: Westside pouf with non-removable cover in fabric Arcadia 02 sabbia, movable backrest in hide 26 invecchiato, base in mat brown nickel.

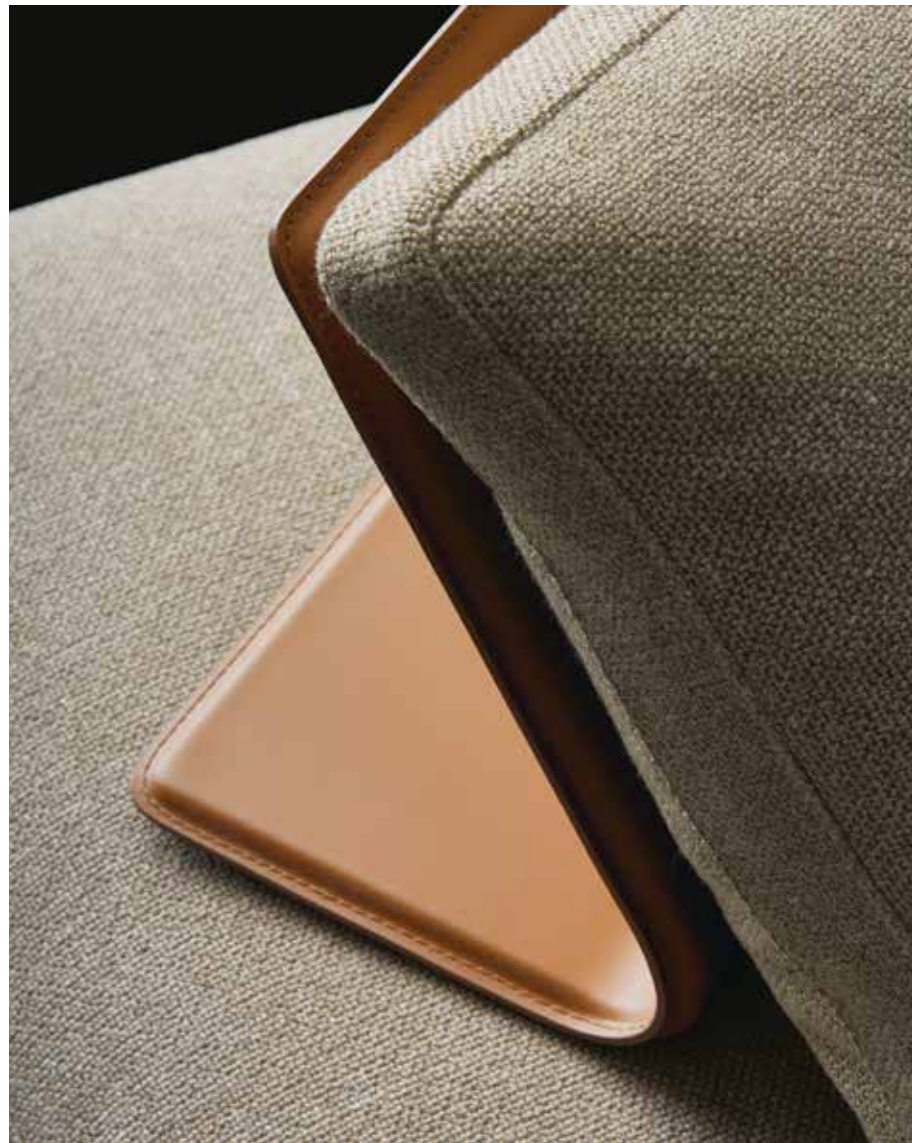







Qui e nella pagina precedente: divano Westside con rivestimento sfo-  
derabile in pelle Silk 10 terracotta, cuscini in tessuto Lero 01 écreu, ba-  
samento in brown nickel opaco. Elemento retro divano con mensola,  
esterno in cuoio 29 tortora, interno in brown nickel opaco.

This and previous page: Westside sofa with removable cover in leather  
Silk 10 terracotta, cushions in fabric Lero 01 ecru, base in mat brown  
nickel. Element behind the sofa with shelf, exterior in hide 29 tortora,  
interior in mat brown nickel.







Qui e nella pagina precedente: divano Westside in tessuto sfoderabile Arcadia 05 bronzo, cuscini in tessuto Siro 04 notte, basamento in brown nickel opaco. Tavolini Westside, piano in marmo sahara noir opaco finitura poliester e in olmo nero, struttura in olmo nero. Poltrona Kay Lounge in pelle non sfoderabile Silk 06 roccia e struttura in cromo satinato. Tavolino Nara in legno massello noce gold. Sistema Code, contenitori retroilluminati in olmo nero e laccato metallico ottone con top in marmo zecevo levigato, boiserie in tessuto lino chiaro e laccato opaco canapa e mensole retroilluminate in laccato metallico ottone. Tappeto Plain tortora. Sotto: dettaglio del tavolino retro divano in olmo nero con cassetti laccato opaco roccia.

This and previous page: Westside sofa in removable fabric Arcadia 05 bronzo, cushions in fabric Siro 04 notte, base in mat brown nickel. Westside coffee tables, top in mat marble sahara noir with polyester finish and in black elm, black elm structure. Kay Lounge armchair in non-removable leather Silk 06 roccia and brushed chrome structure. Nara coffee table in solid wood gold walnut. Code system, backlit storage units in black elm and metal lacquer ottone with top in mat marble zecevo, wall panelling in fabric lino chiaro and mat lacquer canapa and backlit shelves in metal lacquer ottone. Carpet Plain tortora. Below: close up of the back sofa coffee table in black elm with roccia mat lacquered drawers.



In questa pagina: chaise longue Westside con rivestimento sfoderabile in tessuto Arcadia 05 bronzo, schienale in cuoio 29 tortora e brown nickel opaco, basamento in brown nickel opaco.

This page: Westside chaise longue with removable cover in fabric Arcadia 05 bronzo, backrest in hide 29 tortora and brown nickel, base in mat brown nickel.







Qui e nella pagina precedente: divano Westside con rivestimento sfo-  
derabile in tessuto Antea 04 canapa, cuscini in velluto Persia 1404  
carbone, basamento in brown nickel opaco. A sinistra: dettaglio dello  
schienale con mensola, esterno in cuoio 29 tortora, interno in brown  
nickel opaco. Sotto: dettaglio del bracciolo Slim, esterno in cuoio 29  
tortora, interno in brown nickel opaco. Nella pagina successiva: ta-  
volino retro divano in olmo nero con cassette laccato opaco roccia.  
Elemento retro divano con mensola, esterno in cuoio 29 tortora inter-  
no in brown nickel opaco.

This and previous pages: Westside sofa with removable cover in fabric  
Antea 04 canapa, cushions in velvet Persia 1404 carbone, base in mat  
brown nickel. Left: close up of the backrest with shelf, exterior in hide  
29 tortora, interior in mat brown nickel. Below: close up of the armrest  
Slim, exterior in hide 29 tortora, interior in mat brown nickel. Next  
page: back sofa coffee table in black elm with roccia mat lacquered  
drawers. Back sofa element with shelf, exterior in hide 29 tortora, in-  
terior in mat brown nickel.







## WESTSIDE

Design Jean-Marie Massaud, 2019

Struttura in legno e derivati. Cuscino schienale e seduta in poliuretano espanso a quote differenziate, rullo in poliuretano espanso, prerivestimento in tela cotone e piuma. Cuscini opzionali in tela cotone e piuma. Basamento verniciato brown nickel opaco.  
Rivestimento sfoderabile in tessuto o pelle. Giunta verticale nella fascia perimetrale della seduta, per la versione in tessuto posizionata al centro, per la versione in pelle su tutti gli angoli. Bracciolo Slim, schienale chaise longue, schienale con mensola ed elementi retro divano con struttura in alluminio verniciato brown nickel opaco, rivestiti all'esterno in cuoio colori. Poggiatesta e schienale mobile con struttura in metallo rivestito in cuoio colori. Tavolini retro divano con struttura in olmo nero e cassetto opzionale in laccato opaco colori, laccato lucido colori o laccato metallico ottone o bronzo.

Structure in wood and wood-by products. Backrest cushion and seat in differentiated-density polyurethane foam, roll cushion in expanded polyurethane, pre-cover in cotton canvas and down. Optional cushions in cotton canvas and down. Base painted in mat brown nickel. Removable cover in fabric or leather. Vertical stitching in the perimeter band of the seating cushion, for the version in fabric it is positioned in the middle, for the version in leather on all the corners. Armrest Slim, chaise longue backrest, backrest with shelf and back sofa elements with structure in mat painted brown nickel aluminium, covered in hide on the outside. Headrest and movable backrest with structure covered in hide in the sample colours. Back sofa coffee tables with black elm structure and optional drawer in mat lacquered colours, glossy lacquered colours or metal lacquered ottone or bronzo.

### Tipologie bracciolo Arm types



bracciolo I 200 h 580  
arm w 7 3/4" h 22 3/4"



bracciolo Slim I 200 h 430  
Slim arm w 7 3/4" h 17"



senza bracciolo  
without arm

### Tipologie cuscino Cushion types



cuscinio schienale  
backrest cushion



cuscinio schienale con rullo  
backrest cushion with roll cushion



cuscinio schienale con poggiatesta  
backrest cushion with headrest

### Composizioni bifacciali

Per la progettazione di una composizione bifacciale partire da una combinazione lineare, successivamente accostare gli elementi posteriormente e/o lateralmente.

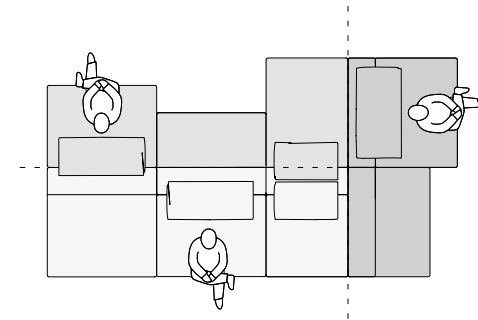

### Double-sided compositions

To design a double-sided composition always start from a linear combination, then add the units to the back or to the side of the sofa.

### Esempi di accostamenti bifacciali

Il bracciolo non può avere funzione di schienale (1), per questo tipo di configurazione usare un elemento angolare. Gli schienali non sono allineabili con sedute su lato opposto (2).

### Examples of double-sided solutions

The arm cannot be used as a backrest (1), for this type of layout a corner unit has to be used. If the seat cushions are on the opposite side the backrests are not aligned (2).

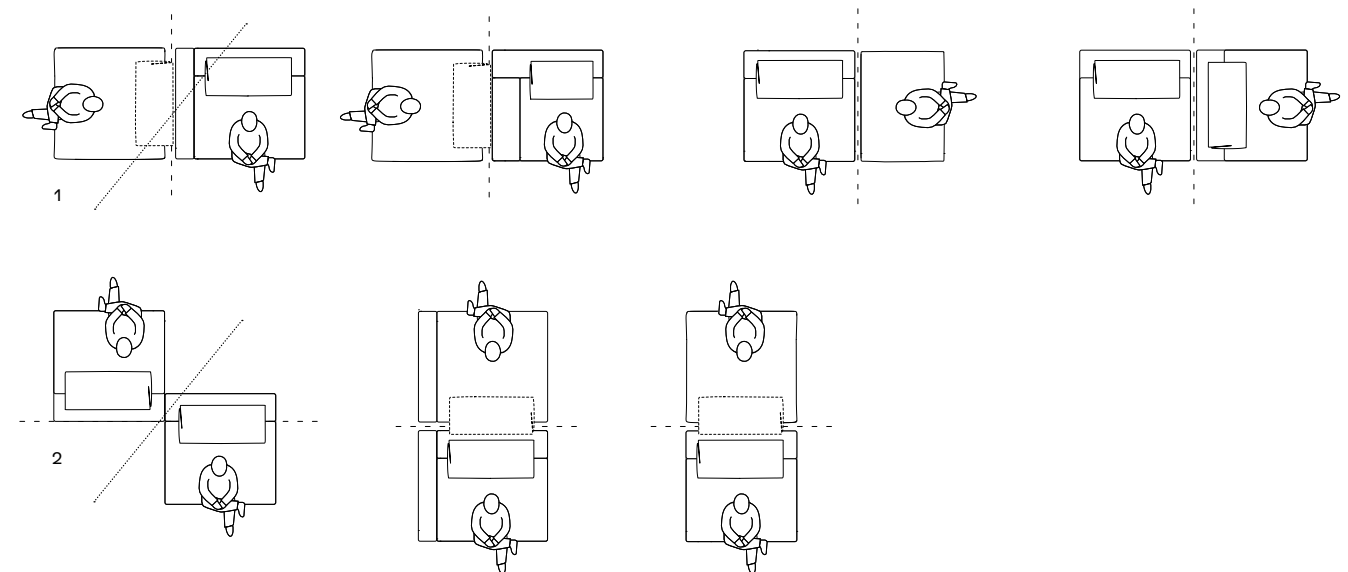

### Tipologie cuscino versione bifacciale Cushion types for double-sided version



opzione 1  
option 1



opzione 2  
option 2



opzione 3  
option 3



opzione 4  
option 4

**Tipologia componenti**  
**Components typology**

**Terminale**  
**End unit**

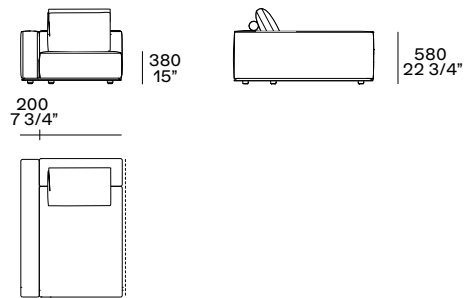

**Terminale con bracciolo Slim**  
**End unit with Slim arm**

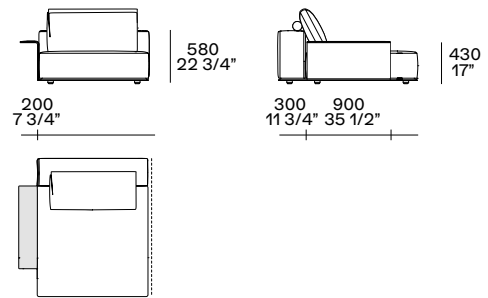

**Chaise longue**  
**Chaise longue**

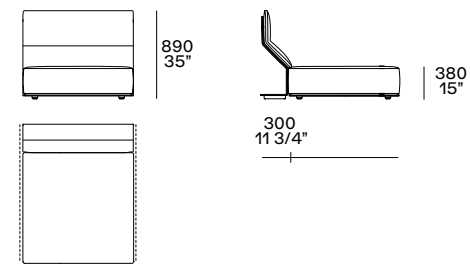

**Chaise longue con bracciolo Slim**  
**Chaise longue with Slim arm**

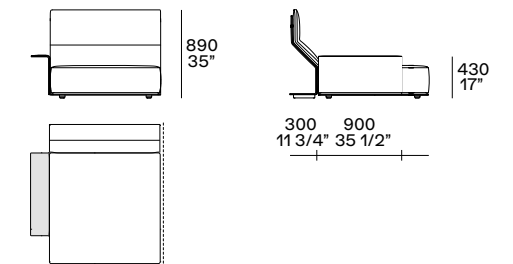

**Terminale isola**  
**Island end unit**

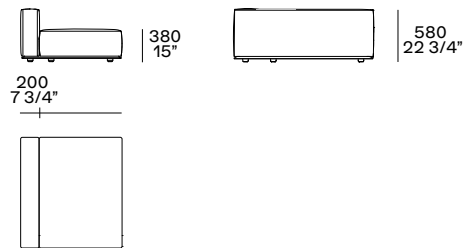

**Pouf**  
**Pouf**

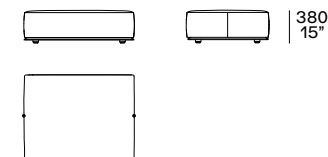

**Angolo sx-dx**  
**Lt-rt corner**

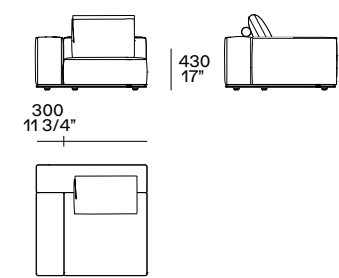

**Centrale**  
**Central unit**

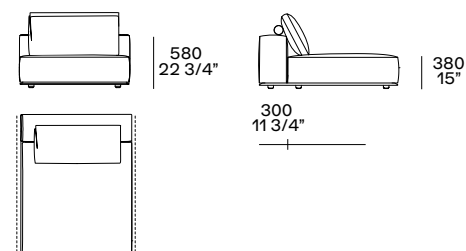

**Centrale con schienale con mensola**  
**Central unit with backrest with shelf**

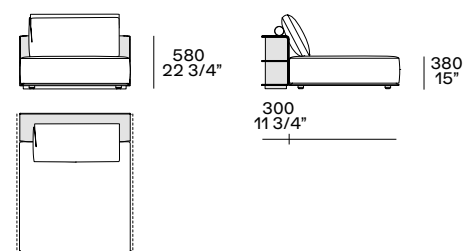

**Elemento retro divano con mensola**  
**Behind sofa element with shelf**

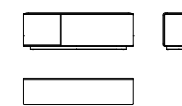

**Elemento retro divano con vano a giorno**  
**Behind sofa element with open compartment**

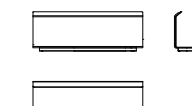

**Tavolino retro divano**  
**Behind sofa coffee table**

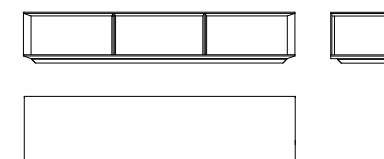

**NB**  
Divano privo di giunzioni, liberamente aggregabile.  
Sofa without joints, allowing combination freedom.

**Modularità componenti**  
**Components modularity**

**Terminale sx-dx**  
**Lt-rt end unit**

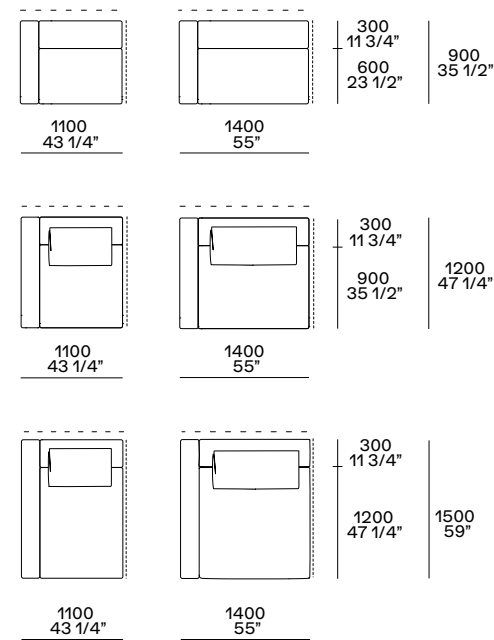

**Centrale**  
**Central unit**

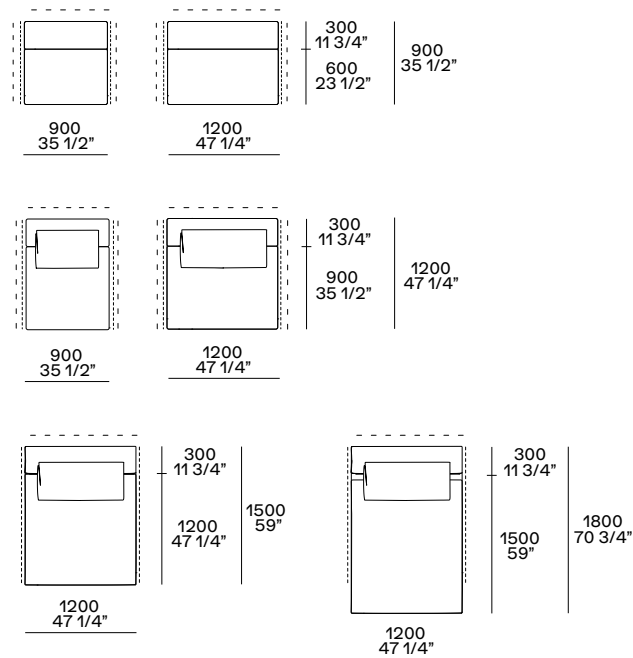

componibilità bifacciale  
double-sided modularity

componibilità lineare  
linear modularity

Posizionamento giunta verticale, nella fascia perimetrale dei pouf, per la versione in tessuto.  
Positioning of the vertical stitching in the perimeter band of the poufs, for the fabric version.

**Terminale sx-dx con bracciolo Slim**  
**Lt-rt end unit with Slim arm**

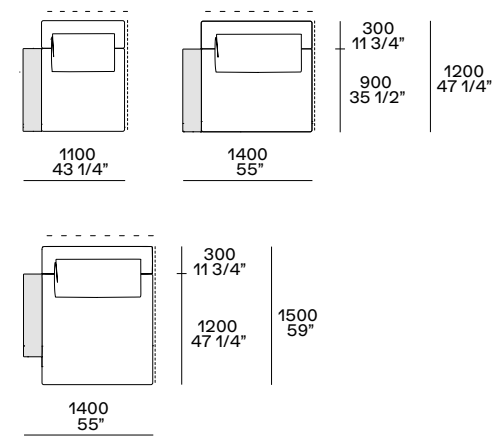

**Terminale isola sx-dx**  
**Lt-rt island end unit**

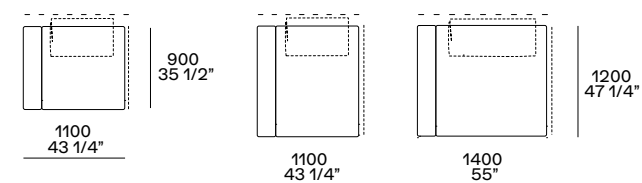

Nelle composizioni bifacciali i cuscini schienale sono appoggiati allo schienale dell'elemento retrostante.  
In the double-sided compositions the backrest cushions rest on the backrest of the element behind.

**Centrale con schienale con mensola**  
**Central unit with backrest with shelf**

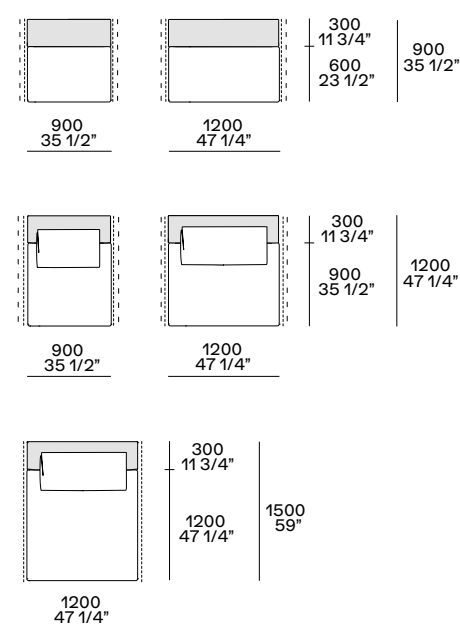

**Chaise longue**  
**Chaise longue**

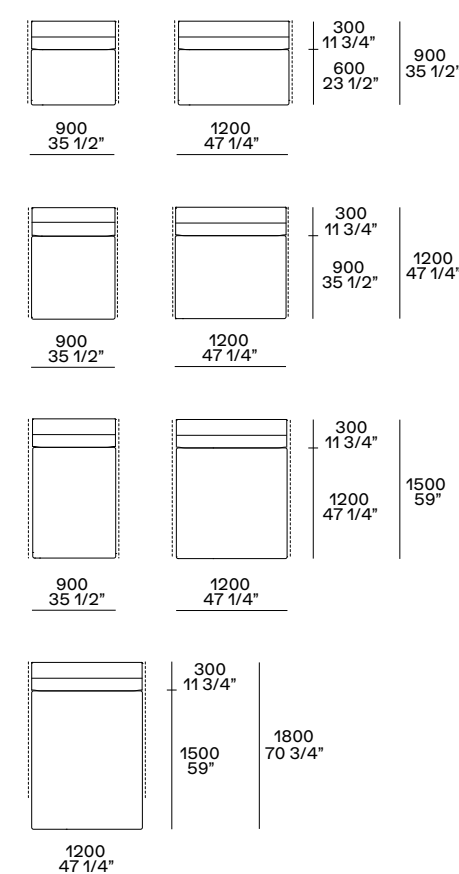

**Pouf**  
**Pouf**

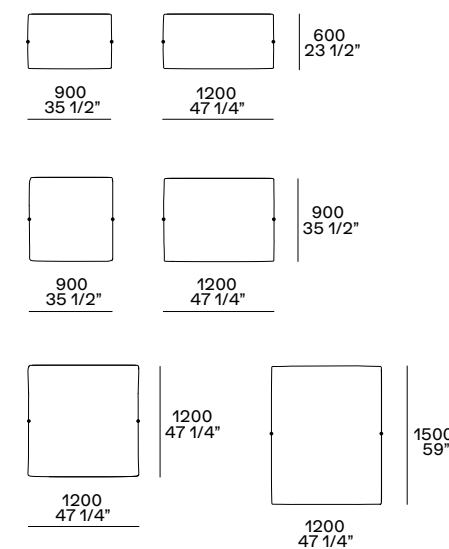

Usa terminale, centrale, angolare e bifacciale su tutti i lati tranne che per il modulo 1200x600 componibile in bifacciale solo su lato lungo.  
Terminal, central, corner and double-sided use on all sides except for the 1200x600 module, which is double-sided modular only on the long side.

**Chaise longue sx-dx con bracciolo Slim**  
**Lt-rt chaise longue with Slim arm**

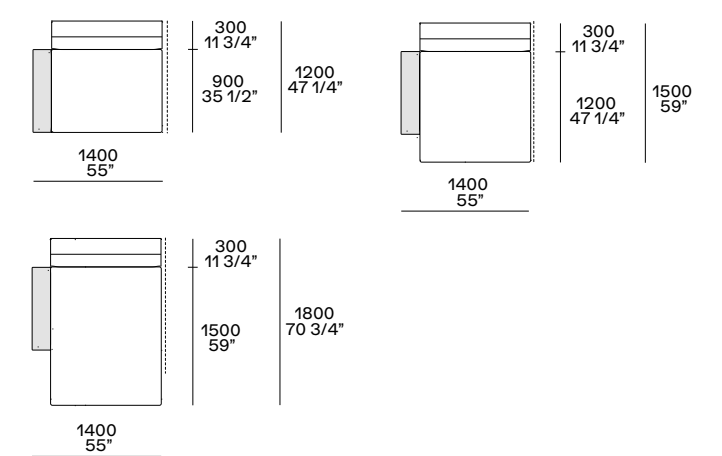

**Angolo sx-dx**  
**Lt-rt corner**

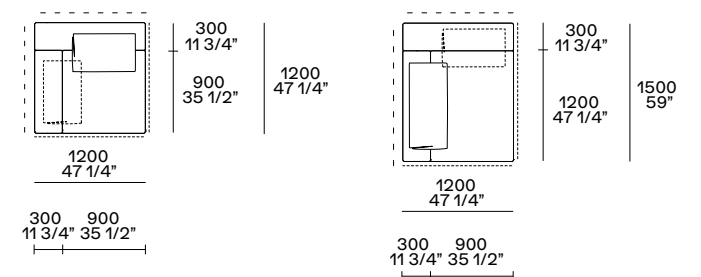

**Cuscino schienale con o senza rullo**  
**Backrest cushion with or without roll**

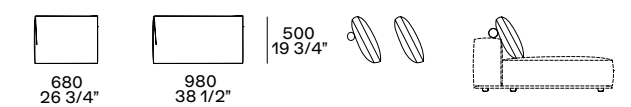

rullo Ø 90  
roll Ø 3 1/2"

**Cuscino schienale con poggiatesta**  
**Backrest cushion with headrest**

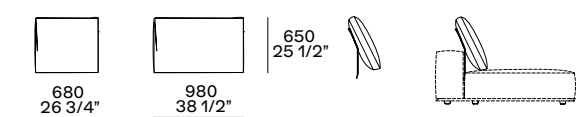

Non utilizzabile su pouf, chaise longue e centrale con schienale con mensola.  
Not to be used on pouf, chaise longue and central unit with backrest with shelf.

**Modularità componenti**  
**Components modularity**

**Elemento retro divano con mensola**  
**Behind sofa element with shelf**

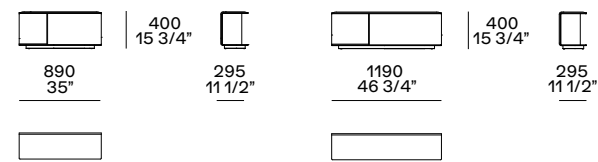

**Elemento retro divano con vano a giorno**  
**Behind sofa element with open compartment**

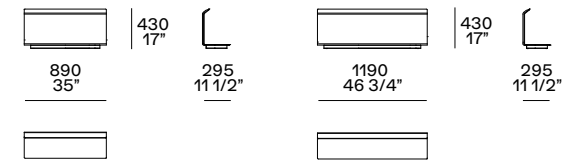

**Tavolino retro divano**  
**Behind sofa coffee table**

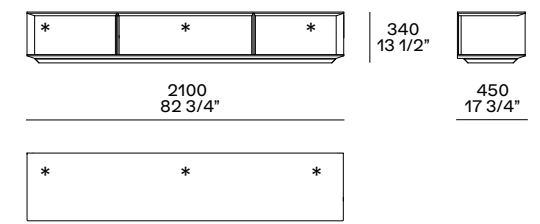
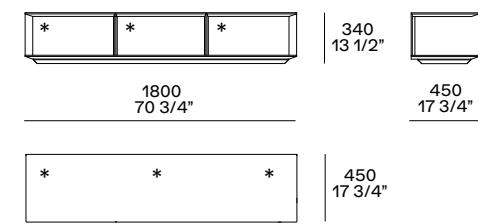

**Schienale mobile**  
**Movable backrest**

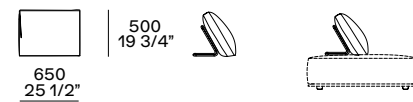

Utilizzabile solo su pouf.  
To be used only on pouf.

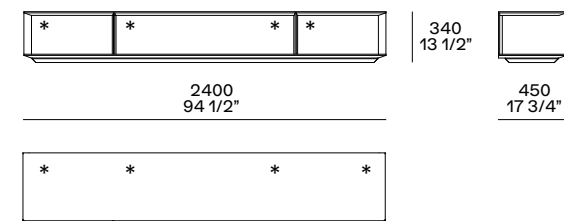

**Cuscini opzionali comfort**  
**Optional comfort cushions**

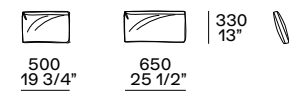

**Cuscino opzionale a fascia**  
**Optional band cushion**

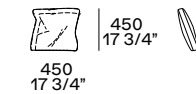

**Cassetto opzionale \***  
**Optional drawer \***

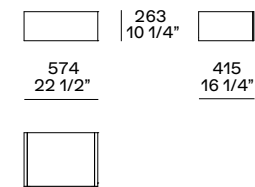

# BELLPORT

Linee classiche e seduta profonda caratterizzano divani, chaise longue, pouf e day bed della collezione Bellport, da combinare a piacere per creare il proprio comfort su misura. Con bracciolo basso o alto, Bellport è disponibile tesato o con fondo piega ed elegante bordo in seta, in sette colori.

Classic lines and deep seats characterize sofas, chaise longue, poufs, and day bed of the Bellport collection, to be combined as desired to create your own tailor-made comfort. With low or high armrest, Bellport is available with stretched or slip-cover and an elegant edge in silk, in seven colours.







Qui e nelle pagine precedenti: divani Bellport in pelle sfoderabile Nabuk 09 ruggine, cuscini con decoro e poggiatesta in pelle Nabuk 09 ruggine, cuscini in velluto Persia 1404 carbone, piedini con profilo brown nickel opaco. Al centro, tavolini Creek, quadrato con piano superiore in marmo sahara noir lucido, rettangolare con superiore in vetro fumé, piani inferiori in olmo nero e struttura brown nickel satinato. Accanto ai divani, tavolini Creek rotondi con piano superiore in nero assoluto texture juta, piano inferiore in olmo nero e struttura brown nickel satinato. Tavolino Creek rettangolare con piano superiore in vetro fumé e piano inferiore in laccato lucido moka, struttura brown nickel satinato. Pouf New York rivestimento sfoderabile in tessuto Naxos 16 sabbia e piedini brown nickel opaco.

This and previous pages: Bellport sofas in removable leather Nabuk 09 ruggine, cushions with decoration and lower back cushion in leather Nabuk 09 ruggine, cushions in velvet Persia 1404 carbone, feet with profile in mat brown nickel. At the center, Creek coffee tables, square version with top in glossy marble sahara noir, rectangular version with top in fumé glass, lower shelves in black elm and mat brown nickel structure. Next to the sofas, round Creek coffee tables with top in nero assoluto texture juta, lower shelf in black elm and brushed brown nickel structure. Rectangular Creek coffee table with top shelf in fumé glass and lower shelf in moka glossy lacquered, brushed brown nickel structure. New York pouf with removable cover in fabric Naxos 16 sabbia and mat brown nickel feet.









Nella pagina precedente: divano Bellport con bracciolo basso, rivestimento sfoderabile in tessuto Kushiro 07 ferro, cuscini e poggiatesta in velluto Persia 1404 carbone, cuscini con decoro in tessuto Kushiro 07 ferro e piedini con profilo in champagne opaco. Qui e nella pagina successiva: divano Bellport con bracciolo alto, rivestimento sfoderabile in tessuto Kushiro 08 tortora, cuscini con decoro e poggiatesta in tessuto Kushiro 08 tortora, cuscini in velluto Persia 1404 carbone e piedini in brown nickel opaco.

Previous page: Bellport sofa with low armrest, removable cover in fabric Kushiro 07 ferro, cushions and lower back cushion in velvet Persia 1404 carbone, cushions with decoration in fabric Kushiro 07 ferro and feet with profile in mat champagne. This and next page: Bellport sofa with high armrest, removable cover in fabric Kushiro 08 tortora, cushions with decoration and lower back cushion in fabric Kushiro 08 tortora, cushions in velvet Persia 1404 carbone and feet in mat brown nickel.







Qui e nella pagina precedente: divani Bellport con bracciolo basso, rivestimento sfoderabile in pelle Nabuk 09 ruggine, piedini con profilo in brown nickel opaco. Al centro, tavolini Creek, quadrato con piano superiore in marmo sahara noir lucido, rettangolare con superiore in vetro fumé, piani inferiori in olmo nero e struttura brown nickel satinato. Accanto ai divani, tavolini Creek, rotondo con piano superiore in nero assoluto texture juta e piano inferiore in olmo nero, rettangolare con piano superiore in vetro fumé e piano inferiore in laccato lucido moka, entrambi con struttura brown nickel satinato.

This and previous page: Bellport sofas with low armrest, removable cover in leather Nabuk 09 ruggine, feet with profile in mat brown nickel. At the center, Creek coffee tables, square with top shelf in glossy marble sahara noir, rectangular with top shelf in fumé glass, lower shelves in black elm with mat brown nickel structure. Next to the sofas, Creek coffee tables, round with top shelf in nero assoluto texture juta and lower shelf in black elm, rectangular with top shelf in fumé glass and lower shelf in moka glossy lacquered, both with structure in brushed brown nickel.







Qui e nella pagina precedente: divani Bellport con bracciolo basso, rivestimento sfoderabile in tessuto Olimpia 58 bianco, cuscino in tessuto Skyros 02 sabbia, cuscini e poggiatesta in tessuto Olimpia 58 bianco, piedini in champagne opaco. Nella successiva: divani Bellport in tessuto sfoderabile Naxos 07 cemento, cuscino in tessuto Sendai 03 fango, pouf Bellport in pelle sfoderabile Soft 13 carbone, piedini in champagne opaco. Tavolini Creek, piani in marmo calacatta oro lucido e laccato lucido canapa con struttura champagne satinato, piani in vetro fumé e olmo nero con struttura in brown nickel satinato. Tavolino Soori in metallo finitura bronzo anticato. Composizione Wall System in rovere spessart e schienali in laccato lucido canapa. Tappeto Frame grey.

This and previous page: Bellport sofas with low armrest in removable fabric Olimpia 58 bianco, cushion in fabric Skyros 02 sabbia, lower back cushions in fabric Olimpia 58 bianco, feet in mat champagne. Next page: Bellport sofas in removable fabric Naxos 07 cemento, cushion in fabric Sendai 03 fango, poufs Bellport in removable leather Soft 13 carbone, feet in mat champagne. Creek coffee tables, top in glossy marble calacatta oro and canapa glossy lacquer with structure in brushed champagne, top in glass fumé and black elm with structure in brushed brown nickel. Soori coffee table in metal with antique bronze finish. Wall System composition in spessart oak and backs in glossy lacquer canapa. Carpet Frame grey.







In questa pagina: Bellport elemento XL rivestimento sfoderabile in pelle Nabuk 02 tortora, cuscini con decoro in tessuto Nayoro 02 sabbia e pelle Nabuk 02 tortora, piedini con profilo in brown nickel opaco. Nella successiva: divano Bellport con bracciolo basso, rivestimento sfoderabile con fondopiega in tessuto Naxos 32 bordeaux e bordura in seta colore acciaio, cuscini con decoro e poggiatesta, piedini in brown nickel opaco.

This page: XL element Bellport with removable cover in leather Nabuk 02 tortora, cushions with decoration in fabric Nayoro 02 sabbia and leather Nabuk 02 tortora, feet with profile in mat brown nickel. Next page: Bellport sofa with low armrest, removable slipcover in fabric Naxos 32 bordeaux and border in silk colour acciaio, cushions with decoration and lower back cushions, mat brown nickel feet.





In questa pagina: day bed Bellport in pelle sfoderabile Nabuk 08 prussia, cuscino a rullo con cinghia in cuoio 02 nero e piedini con profilo in brown nickel opaco. Tavolino Creek, piano superiore in marmo sahara noir lucido, piano inferiore in olmo nero e struttura brown nickel satinato. Composizione Quid con bacheche a giorno, struttura e schienali in olmo nero, ripiani in olmo nero e vetro trasparente extrachiario con luce a led integrata, boiserie centrale in laccato metallico ottone. Tavolino Soori in metallo finitura bronzo anticato.

This page: Bellport day bed in removable leather Nabuk 08 prussia, roll cushion with belt in hide 02 nero and feet with profile in mat brown nickel. Creek coffee table with top in glossy marble sahara noir, lower shelf in black elm and structure in brushed brown nickel. Quid composition with open display cases, structure and backs in black elm, shelves in black elm and extra light transparent glass with integrated led light, metal lacquered ottone central wall panelling. Soori coffee table in metal with antique bronze finish.



## BELLPORT

Design Jean-Marie Massaud, 2018

Struttura in legno e derivati. Cuscini schienale e seduta in poliuretano espanso a quote differenziate. Pre-rivestimento in tela cotone e piuma. Piedini fusione di alluminio verniciato, profilo estrusione di alluminio verniciato, verniciatura brown nickel opaco o champagne opaco.

Rivestimento tesato sfoderabile in tessuto o pelle.

Rivestimento con fondopiega sfoderabile in tessuto con bordura in seta colori a campionario, disponibile solo per divani fissi, day bed, elemento XL centrostanza e pouf centrostanza.

Structure in wood and wood-by products. Backrest cushions and seat cushion in multi-density polyurethane foam.

Pre-cover in cotton canvas and down. Feet in painted aluminium casting, profile in painted aluminium extrusion, finish mat brown nickel or mat champagne.

Removable stretched cover in fabric or leather.

Removable slipcover in fabric with silk border in the colours as per sample book, available only for: fixed sofas, day bed, XL element and pouf for central use.

### Tipologie bracciolo Arm types



bracciolo basso  
low arm



bracciolo alto  
high arm

### Tipologie piedino e rivestimento Feet and cover types



piedino e rivestimento tesato  
feet and stretched cover



piedino con profilo e rivestimento tesato  
feet with profile and stretched cover



piedino e rivestimento con fondopiega  
feet and slipcover

### Divano con bracciolo basso Sofa with low arm

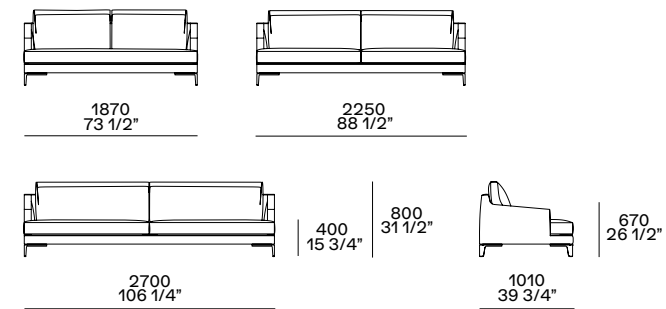

### Chaise longue centrostanza Freestanding chaise longue

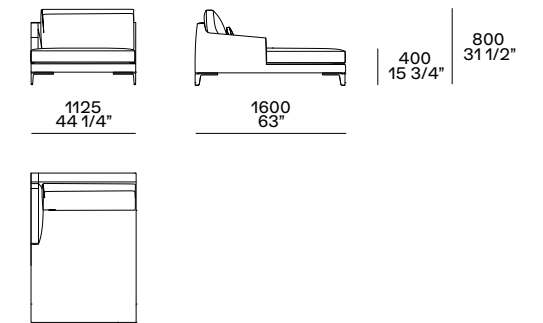

### Day bed centrostanza Freestanding day bed

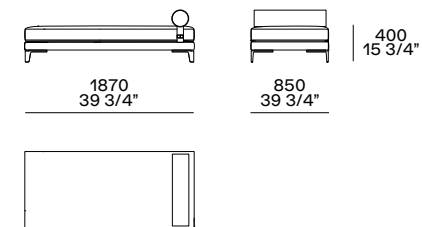

con cuscino a rullo e cinghia in cuoio colori  
with roll cushion and band in hide colours

### Pouf centrostanza Freestanding pouf

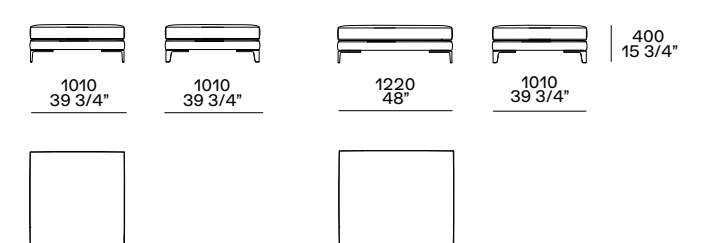

### Elemento XL centrostanza Freestanding XL element

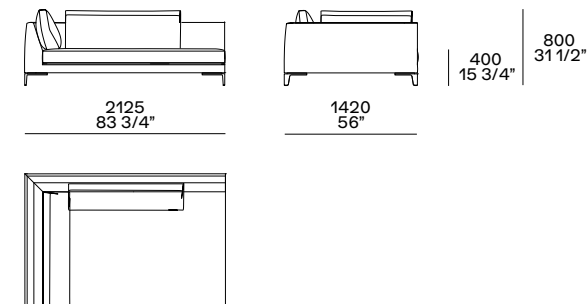

### Cuscino poggiatesta p 80 Lower back cushion d 3 1/4"

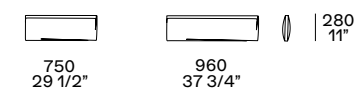

l 750 abbinabile agli schienali l 810 - 1000  
l 960 abbinabile allo schienale l 1220  
w 29 1/2" for back w 32" - 39 1/4"  
w 37 3/4" for back w 48"

### Cuscini opzionali Optional cushions

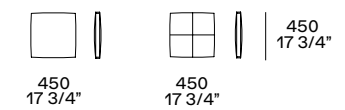

con decoro  
with decoration

**Terminale sx-dx con bracciolo basso**  
**Lt-rt end unit with low arm**

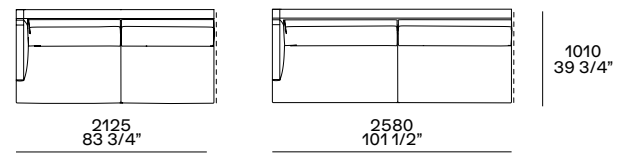

**Terminale penisola sx-dx con bracciolo basso**  
**Lt-rt peninsula end unit with low arm**

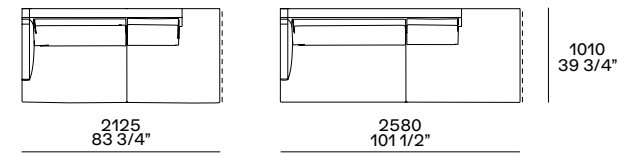

**Terminale sx-dx con bracciolo alto**  
**Lt-rt end unit with high arm**

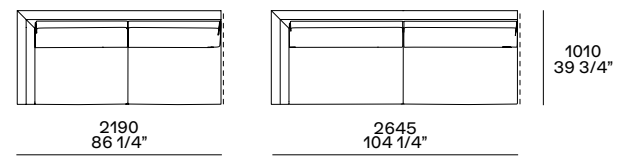

**Terminale penisola sx-dx con bracciolo alto**  
**Lt-rt peninsula end unit with high arm**

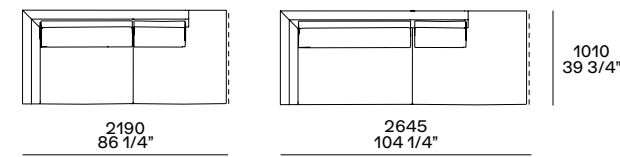

**Centrale penisola sx-dx**  
**Lt-rt peninsula central unit**

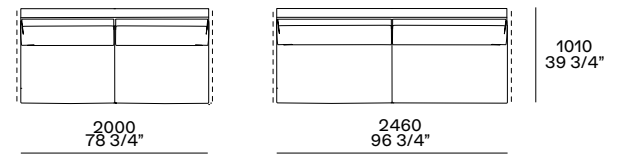

**Centrale**  
**Central unit**

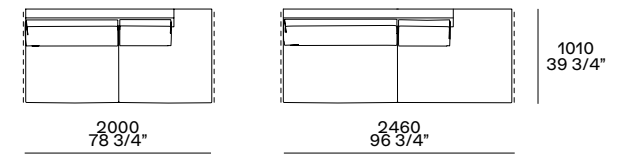

**Pouf centrale**  
**Central unit pouf**

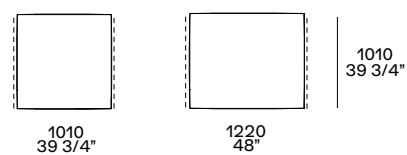

**Angolo sx-dx**  
**Lt-rt corner unit**

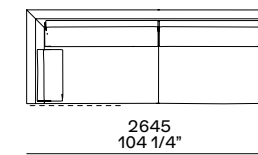
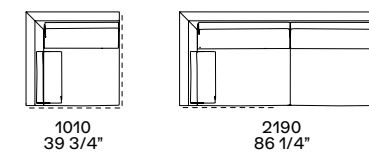

**Angolo penisola sx-dx**  
**Lt-rt peninsula corner unit**

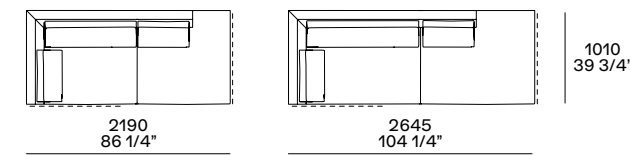

**Chaise longue terminale sx-dx con bracciolo basso**  
**Lt-rt end unit chaise longue with low arm**

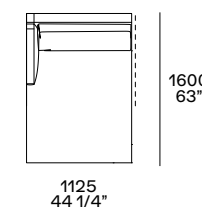

**Elemento XL**  
**XL element**

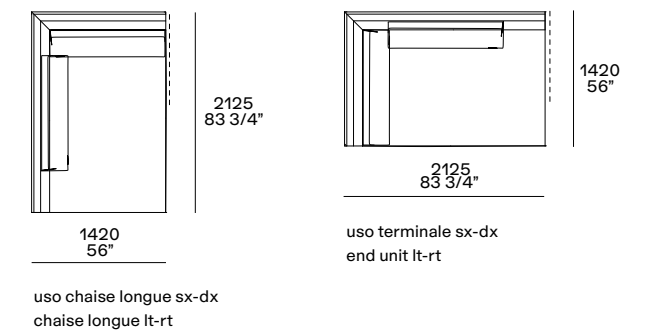

**Terminale angolo sx-dx con bracciolo basso**  
**Lt-rt corner end unit with low arm**

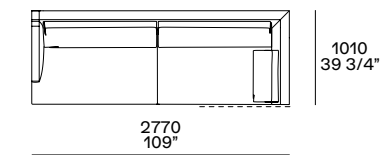

**Pouf terminale sx-dx**  
**Lt-rt end unit pouf**

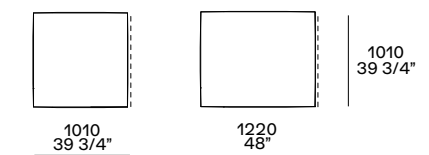

# DUNE

Dune è un sistema di elementi imbottiti dall'aspetto morbido e pieno. Progettato da Carlo Colombo, è molto versatile e permette di creare un numero infinito di composizioni – lineari, ad angolo, con chaise longue. Disponibile in due profondità – large ed extralarge – Dune è la perfetta unione tra semplicità formale e libertà compositiva.

Dune is a system of padded elements with a soft and full look. Designed by Carlo Colombo, it is very versatile and allows you to create an infinite number of compositions – linear, corner, with chaise longue. Available in two depths – large and extra-large – Dune is the perfect union between formal simplicity and compositional freedom.









Qui e nelle pagine precedenti: divano e pouf Dune rivestimento sfoderabile in tessuto Rabat 400 écru, cuscini in tessuto Nancy 101 carbone, velluto Persia 1404 carbone e tessuto Rabat 400 écru con bordura gros-grain nero. Tavolino Home Hotel in olmo nero. Poltrona Mad Chair rivestimento sfoderabile in tessuto Nancy 101 carbone, basamento girevole in brown nickel opaco. Tappeto Frame gold.

This and previous pages: sofa and pouf Dune with removable cover in fabric Rabat 400 ecru, cushions in fabric Nancy 101 carbone, velvet Persia 1404 carbone and fabric Rabat 400 ecru with border in gros-grain nero. Home Hotel coffee table in black elm. Mad Chair armchair with removable cover in fabric Nancy 101 carbone, mat brown nickel swivel base. Carpet Frame gold.







Nella pagina precedente: divano Dune rivestimento sfoderabile in pelle Soft 07 roccia, cuscini in tessuto Sendai 02 tortora e pelle Soft 07 roccia con bordura gros-grain nero. Qui e nella pagina successiva: divano Dune rivestimento sfoderabile in tessuto Skyros 02 sabbia, cuscini in tessuto Skyros 02 sabbia e velluto Persia 1404 carbone con bordura gros-grain nero.

Previous page: Dune sofa with removable cover in leather Soft 07 roccia, cushions in fabric Sendai 02 tortora and leather Soft 07 roccia with border in grosgrain nero. This and next page: Dune sofa with removable cover in fabric Skyros 02 sabbia, cushions in fabric Skyros 02 sabbia and velvet Persia 1404 carbone with border in grosgrain nero.

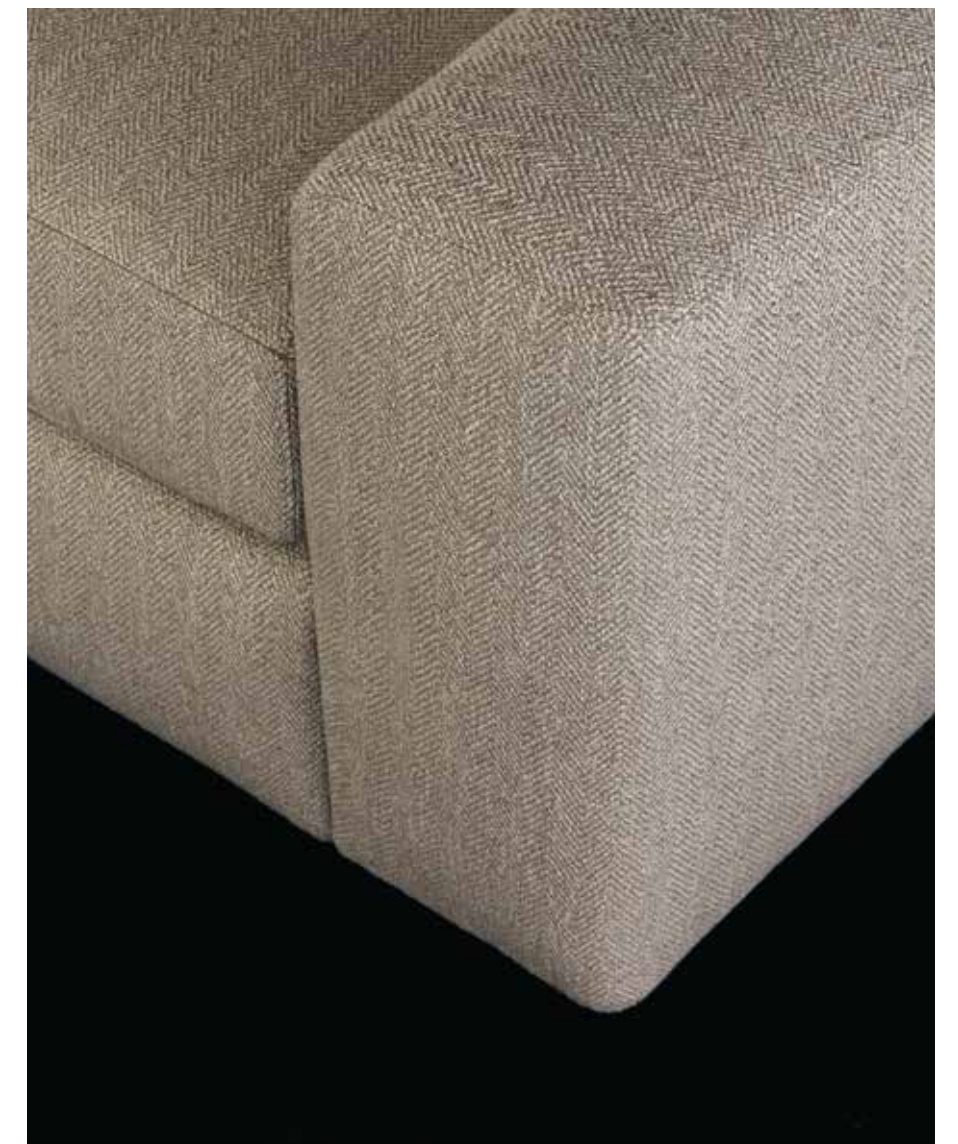



Qui e nella pagina successiva: divano Dune rivestimento sfoderabile in velluto Persia 58 danubio, cuscini in velluto Persia 58 danubio e Persia 1404 carbone con bordura gros-grain sahara. Pouf Dune rivestimento sfoderabile in tessuto Nayoro 04 roccia. Tavolino Soori in metallo finitura bronzo anticato. Poltrona Santa Monica Lounge rivestimento sfoderabile in tessuto Naxos 17 corda e cuciture a cordoncino nero.

This and next page: Dune sofa with removable cover in velvet Persia 58 danubio, cushions in velvet Persia 58 danubio and Persia 1404 carbone with grosgrain border sahara. Dune pouf with removable cover in fabric Nayoro 04 roccia. Soori coffee table in metal with antique bronze finish. Santa Monica Lounge armchair with removable cover in fabric Naxos 17 corda and drawstring stitching nero.





## DUNE

Design Carlo Colombo, 2008

Struttura in poliuretano flessibile stampato con inserti in poliuretano espanso a quote differenziate. Imbottitura seduta in poliuretano espanso a quote differenziate. Prerivestimento parti in tela cotone con interno in piuma e parti in fibra di poliestere accoppiata. Piedini in materiale plastico. Rivestimento sfoderabile in tessuto o pelle.

Structure in flexible moulded polyurethane with inserts in multi-density polyurethane foam. Seat cushion padding in multi-density polyurethane foam. Pre-cover parts in cotton canvas with down inside and parts in coupled polyester fibre. Feet in plastic material. Removable cover in fabric or leather.

### Tipologie bracciolo Arm types



bracciolo h 550  
arm h 21 3/4"



bracciolo h 680  
arm h 26 3/4"

### Modularità componenti, profondità 1020 Components modularity, depth 40 1/4"

#### Divano con bracciolo h 550 Sofa with arm h 21 3/4"

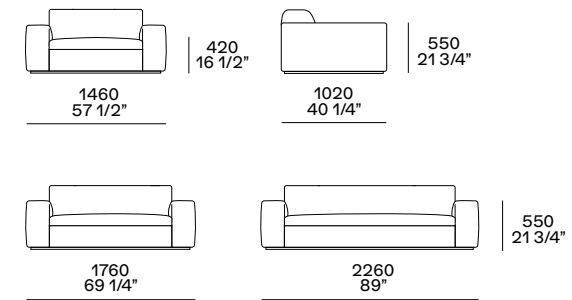

#### Divano con bracciolo h 680 Sofa with arm h 26 3/4"

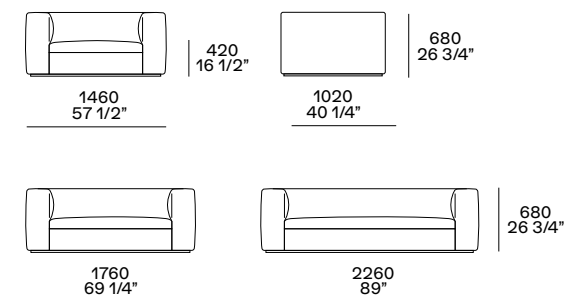

#### Pouf centrostanza Freestanding pouf

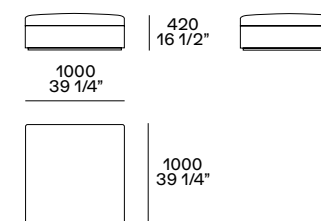

#### Cuscini opzionali Optional cushions

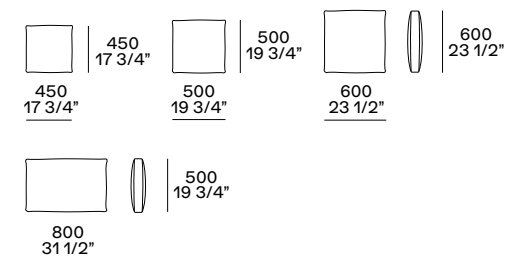

### Modularità componenti, profondità 1230 Components modularity, depth 48 1/2"

#### Divano con bracciolo h 550 Sofa with arm h 21 3/4"

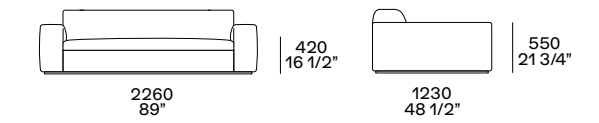

#### Divano con bracciolo h 680 Sofa with arm h 26 3/4"

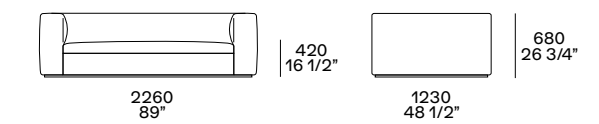

#### Pouf centrostanza Freestanding pouf

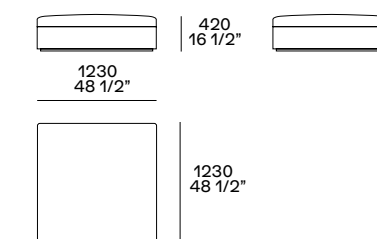

**Modularità componenti, profondità 1020**  
**Components modularity, depth 40 1/4"**

**Terminale sx-dx**  
**Lt-rt end unit**

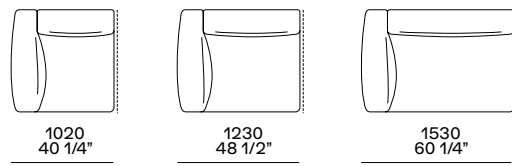

**Centrale**  
**Central unit**

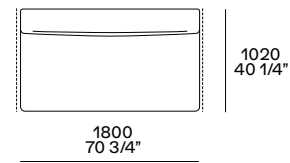
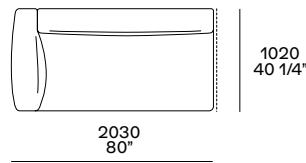
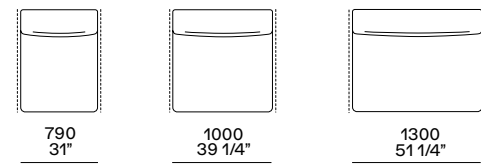

**Terminale sx-dx senza bracciolo**  
**Lt-rt end unit whitout arm**

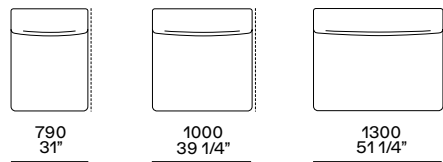

**Terminale penisola sx-dx**  
**Lt-rt peninsula end unit**

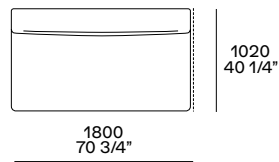
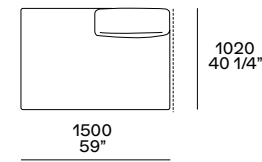

**Angolo sx-dx**  
**Lt-rt corner unit**

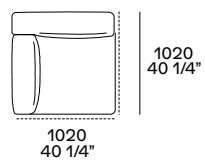

**Pouf angolo sx-dx**  
**Lt-rt corner pouf**

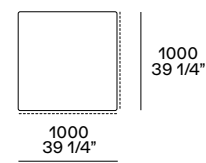

**Pouf terminale sx-dx**  
**Lt-rt end unit pouf**

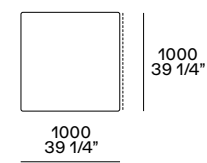

**Pouf centrale**  
**Central pouf**

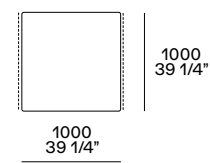

**Modularità componenti, profondità 1230**  
**Components modularity, depth 48 1/2"**

**Terminale sx-dx**  
**Lt-rt end unit**

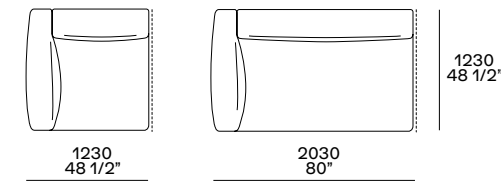

**Centrale**  
**Central unit**

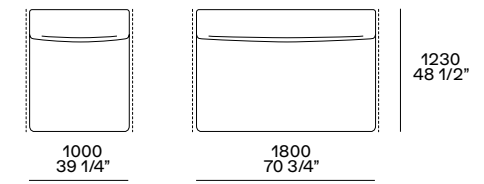

**Angolo sx-dx**  
**Lt-rt corner unit**

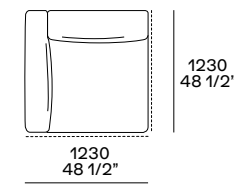

**Pouf angolo sx-dx**  
**Lt-rt corner pouf**

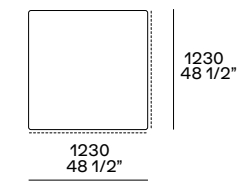

**Pouf terminale sx-dx**  
**Lt-rt end unit pouf**

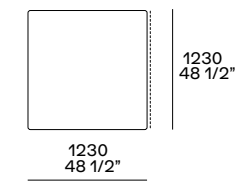

**Pouf centrale**  
**Central pouf**

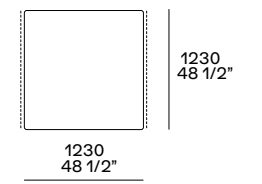

**Modularità componenti, profondità 1020 e 1230**  
**Components modularity, depth 40 1/4" and 48 1/2"**

**Angolo sx-dx**  
**Lt-rt corner unit**

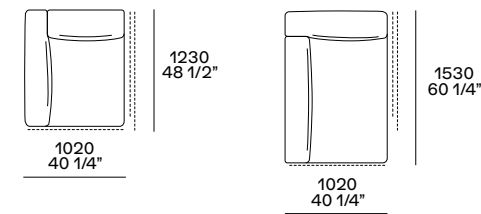

**Chaise longue terminale sx-dx**  
**Lt-rt end unit chaise longue**

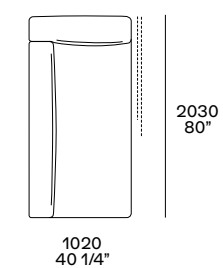
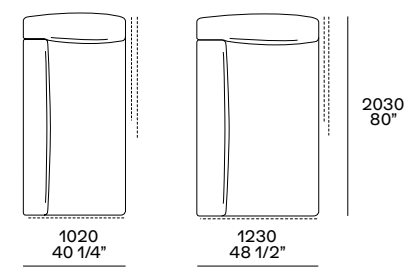
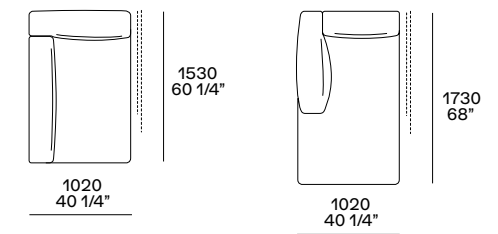

**Terminale angolo sx-dx**  
**Lt-rt corner end unit**

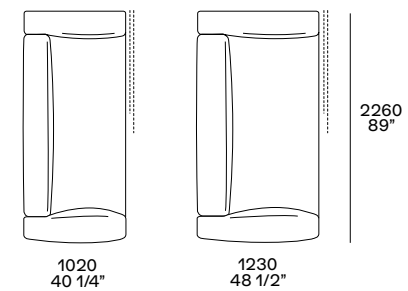



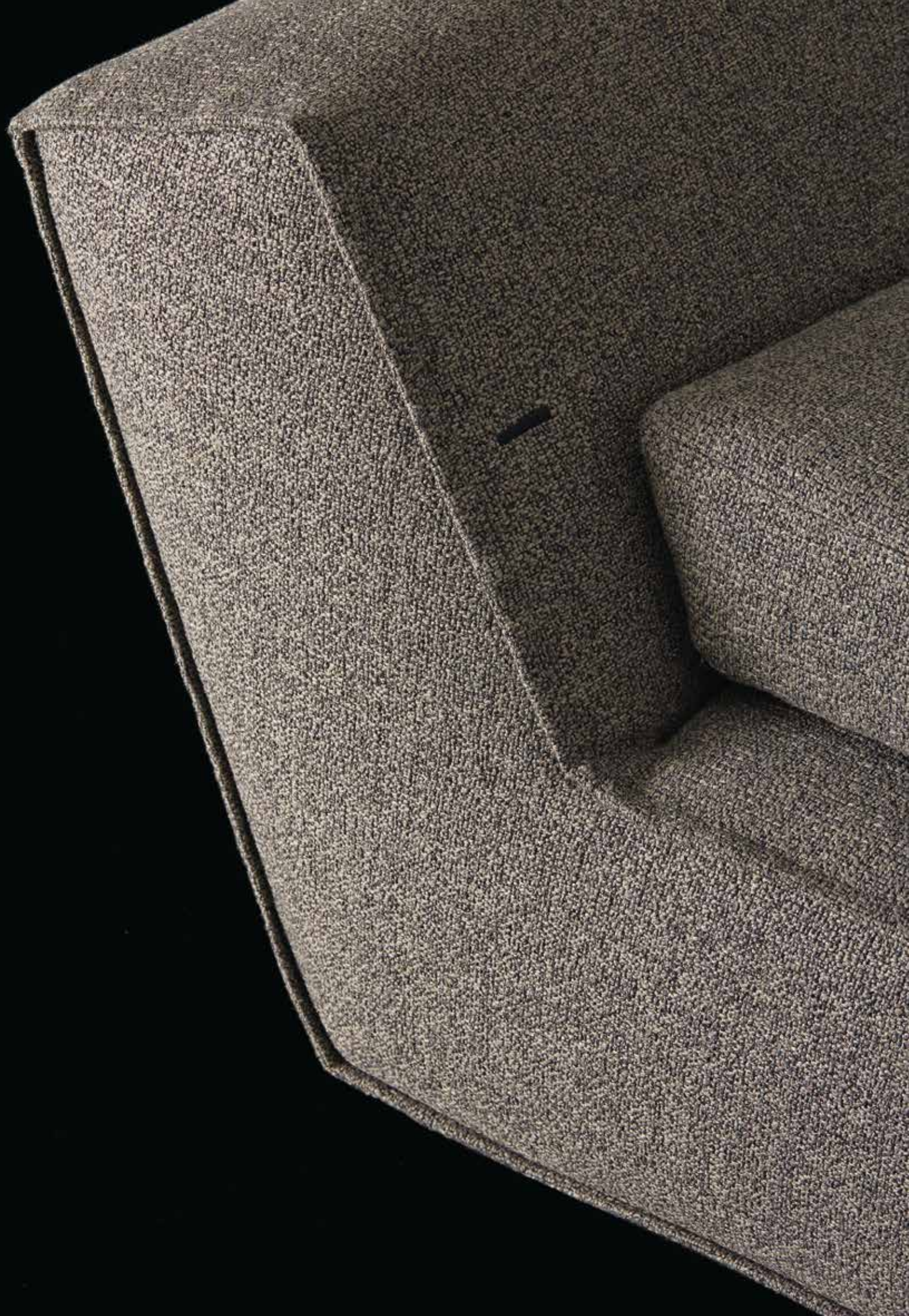

# SYDNEY

Una contaminazione di stili, un mix di tendenze, un equilibrio perfetto tra linee oblique e ortogonali, spigoli vivi e arrotondati: con Sydney, Jean-Marie Massaud riesce a trasformare una serie di volumi geometrici in un divano monoscocca morbido e confortevole. Sydney si riconosce per i piedini sottili e per gli elementi a L che costituiscono la seduta, da completare con cuscini liberi di diverse dimensioni e bracciolo opzionale.

A contamination of styles, a mix of trends, a perfect balance between oblique and orthogonal lines, sharp and rounded edges: with Sydney, Jean-Marie Massaud manages to transform a series of geometric volumes into a soft and comfortable monocoque sofa. Sydney distinguishes itself with its thin feet and L-shaped elements that make up the seat, to be completed with free cushions of different sizes and optional armrest.









Nelle pagine introduttive: divano Sydney in tessuto sfoderabile Lima 43 écreu con cuciture sahara, cuscini in tessuto Skyros 09 oliva e piedini brown nickel lucido. Panca Home Hotel in olmo nero. Composizione Wall System in laccato opaco canapa, schienali in rovere spessart e schienali inclinati in grès porcellanato sahara noir con illuminazione a led integrata. Tappeto Plain natural. Nella pagina precedente: divano Sydney in tessuto sfoderabile Naxos 16 sabbia con cuciture burro, cuscini in tessuto Arcadia 01 avorio e piedini brown nickel lucido. Qui e nella pagina successiva: divano Sydney in tessuto sfoderabile Kitami 07 roccia con cuciture navy e piedini brown nickel lucido.

Introduction pages: Sydney sofa in removable fabric Lima 43 ecru with stitching sahara, cushions in fabric Skyros 09 oliva and glossy brown nickel feet. Home Hotel bench in black elm. Wall System composition in mat lacquered canapa, backs in spessart oak and oblique backs in gres porcelain sahara noir with integrated led lighting. Carpet Plain natural. Previous page: Sydney sofa in removable fabric Naxos 16 sabbia with stitching burro, cushions in fabric Arcadia 01 avorio and glossy brown nickel feet. This and next page: Sydney sofa in removable fabric Kitami 07 roccia with stitching navy and glossy brown nickel feet.





## SYDNEY

Design Jean-Marie Massaud, 2016

Struttura in legno e derivati. Imbottitura in poliuretano flessibile a quote differenziate. Prerivestimento in fibra di poliestere. Piedini in metallo verniciato brown nickel lucido.

Rivestimento finale sfoderabile in tessuto. Decorì con cucitura a cordoncino colori a campionario (escluso velluto).

Cuscini opzionali disponibili in tre dimensioni con rivestimento sfoderabile in tessuto o pelle, decorì con cucitura a cordoncino colori a campionario (escluso velluto e pelle).

Structure in wood and wood by-products. Padding in multi-density flexible polyurethane. Pre-cover in polyester fibre. Feet in glossy brown nickel painted metal. Final cover in removable fabric.

Decorative drawstring stitching in the colours as per sample book (except velvet).

Optional cushions available in three sizes with removable cover in fabric or leather, decorative drawstring stitching in the colours as per sample book (except velvet and leather).

### Terminale sx-dx Lt-rt end unit

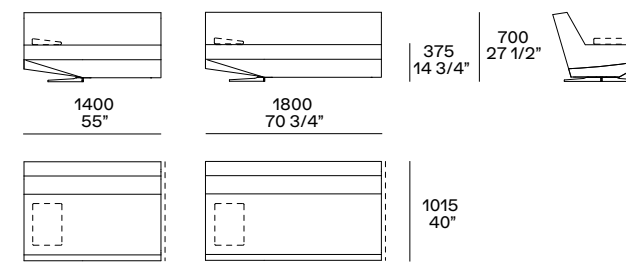

### Terminale penisola sx-dx Lt-rt peninsula end unit

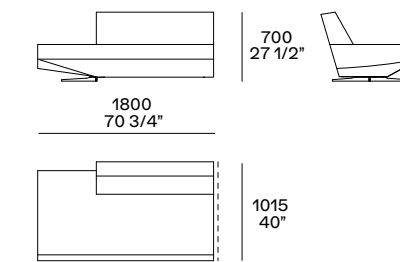

### Centrale Central unit

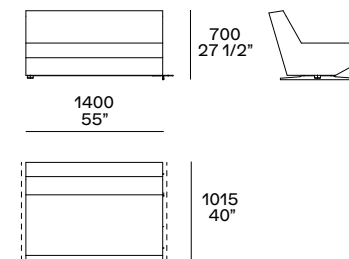

### Angolo Corner unit

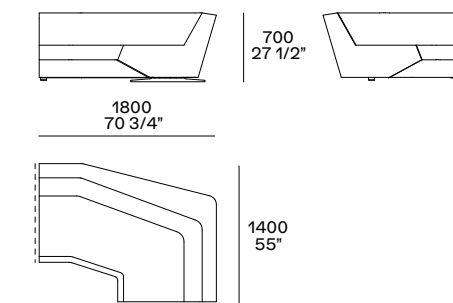

### Terminale chaise longue sx-dx Lt-rt end unit chaise longue

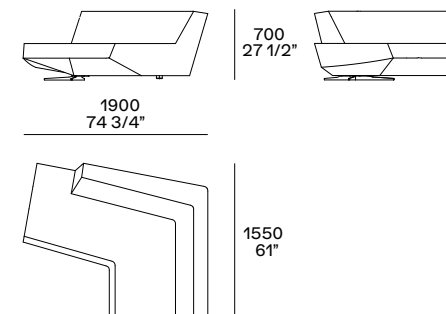

### Cuscini opzionali Optional cushions

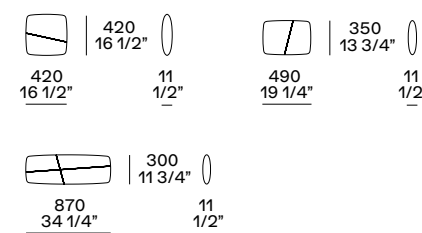

### Bracciolo opzionale sx-dx Lt-rt optional armrest

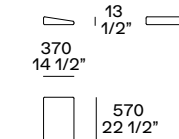

per terminale sx-dx  
for lt-rt end unit



# SHANGAI



Shangai di Carlo Colombo è un sistema di divani dalle forme rigorose, declinato in due versioni di imbottitura – la prima più classica e la seconda, in piuma, più morbida e informale. Il basamento in alluminio, che sembra una linea sottile, è un dettaglio di carattere dal tocco contemporaneo.

Shangai by Carlo Colombo is a system of sofas with rigorous shapes, available in two versions of padding – the first more classic and the second, in down, softer and more informal. The aluminium base, which looks like a thin line, is a detail with a contemporary touch.





Qui e nelle pagine precedenti: divano e pouf Shangai, versione in piuma, rivestimento sfoderabile in tessuto Hannover 14 grafite, cuscini in tessuto Naxos 16 sabbia, zoccolino estetico in alluminio brill. Tavolino Flute in laccato opaco granata. Poltrona Ipanema in rovere spessart e seduta con rivestimento non sfoderabile in pelle Nabuk 01 latte.

This and previous pages: Shangai sofa and pouf, version in down, removable cover in fabric Hannover 14 grafite, cushions in fabric Naxos 16 sabbia, decoration plinth in aluminium brill. Granata mat lacquered Flute coffee table. Ipanema armchair in spessart oak and seat with non-removable cover in leather Nabuk 01 latte.







Qui e nella pagina precedente: divano Shangai, versione in fibra, rivestimento sfoderabile in tessuto Skyros 04 visone, cuscini in velluto Persia 1404 carbone e tessuto Skyros 04 visone, zoccolino estetico in brown nickel opaco.

This and previous page: Shangai sofa, fibre version, removable cover in fabric Skyros 04 visone, cushions in velvet Persia 1404 carbone and fabric Skyros 04 visone, decoration plinth in mat brown nickel.

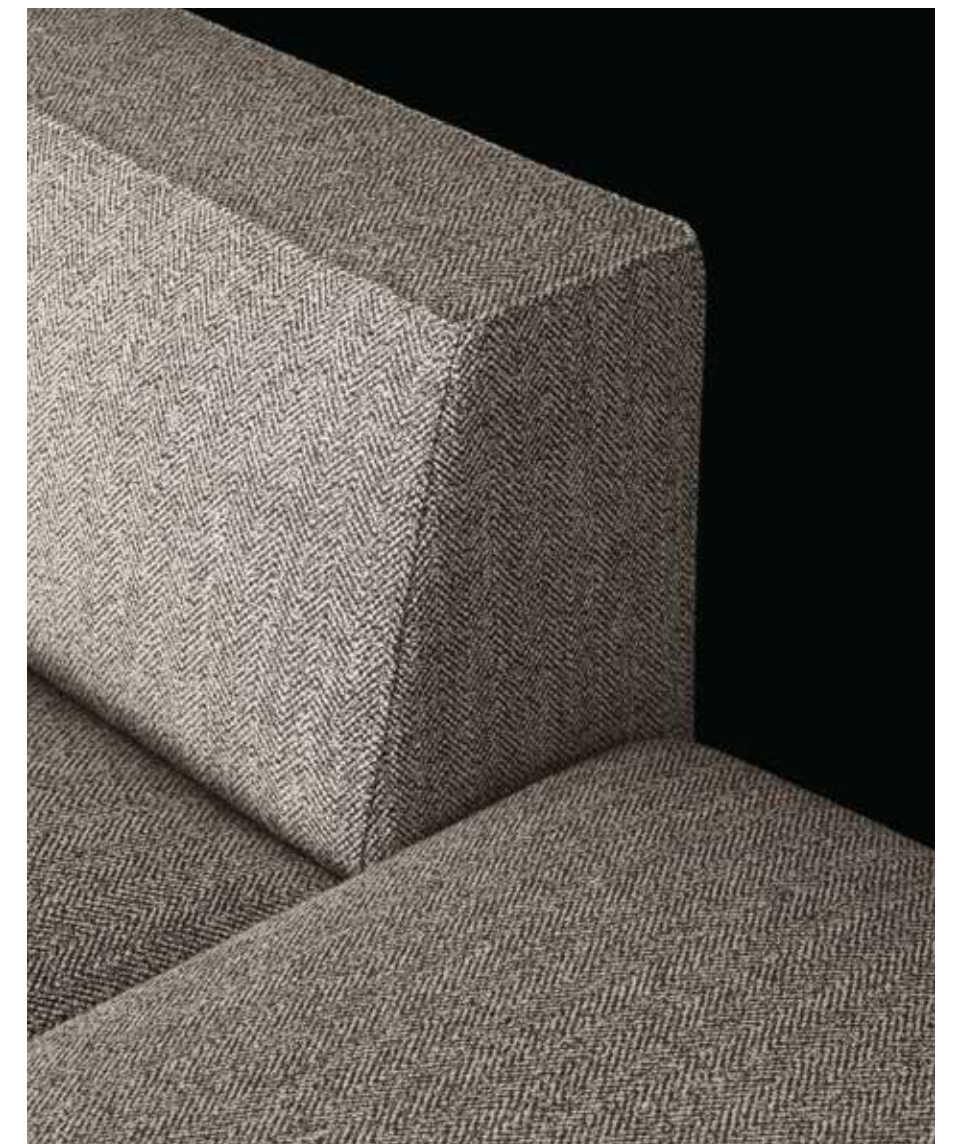

## SHANGAI

Design Carlo Colombo, 2006

Struttura in legno e derivati. Imbottitura struttura, seduta e schienale in poliuretano a quote differenziate.

Prerivestimento versione piuma: parti in tela cotone con interno in piuma e parti in fibra di poliestere accoppiata.

Prerivestimento versione fibra: fibra di poliestere accoppiata.

Piedini in materiale plastico e zoccolino estetico in alluminio brill o in alluminio verniciato brown nickel opaco e lucido.

Rivestimento sfoderabile in tessuto o pelle.

Structure in wood and wood by-products.

Padding of structure, seat cushion and backrest in multi-density polyurethane.

Pre-cover version in down: parts in cotton canvas with down inside and parts in coupled polyester fibre.

Pre-cover fibre version: coupled polyester fibre.

Feet in plastic material and decoration plinth in aluminium brill or in aluminium painted mat and glossy brown nickel.

Removable cover in fabric or leather.

### Divano Sofa

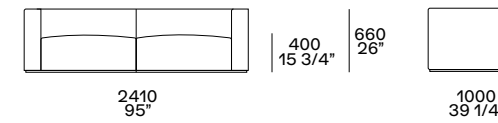
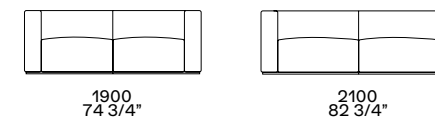

### Terminale sx-dx Lt-rt end unit

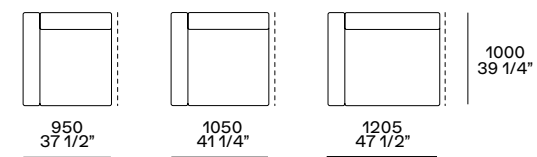

### Angolo sx-dx Lt-rt corner unit

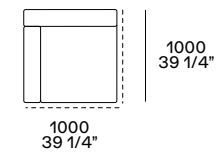

### Pouf angolo sx-dx Lt-rt corner pouf

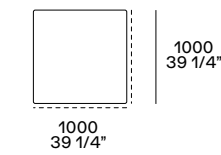

### Pouf centrostanza Freestanding pouf

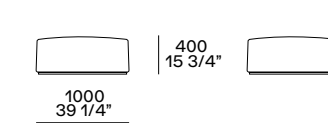

### Terminale senza bracciolo sx-dx Lt-rt end unit without arm

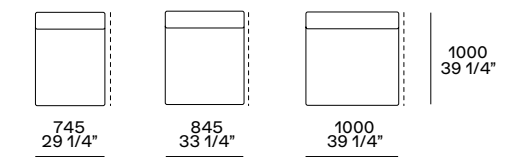

### Centrale Central unit

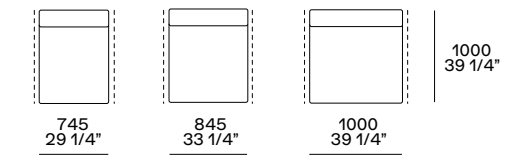

### Pouf terminale sx-dx Lt-rt end unit pouf

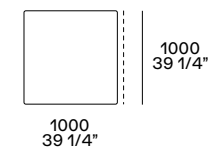

### Pouf centrale Central unit pouf

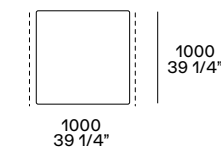

### Chaise longue terminale sx-dx Lt-rt end unit chaise longue

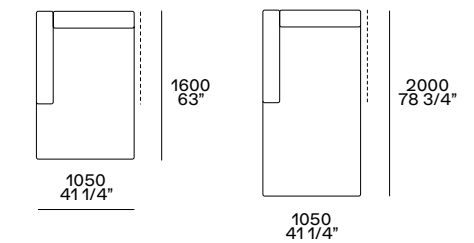

### Cuscini opzionali Optional cushions

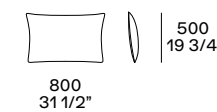
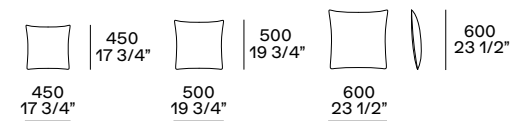



# PARIS SEOUL

Proporzioni generose per Paris Seoul, la collezione di divani disegnata da Jean-Marie Massaud. Un'estetica ultrabold per un archetipo dell'imbottito, che riconduce ogni elemento alla sua forma primaria. Una proposta elegante e completa per le atmosfere più classiche del living, capace di realizzare un comfort evoluto, grazie al meccanismo che permette di regolare a piacere la profondità della seduta.

Generous proportions for Paris Seoul, the sofa collection designed by Jean-Marie Massaud. An ultra-bold aesthetic for an archetype of upholstery, bringing each element back to its primary shape. An elegant and complete offer for the most classic atmosphere of the living area, able to create an evolved comfort, thanks to the mechanism that allows you to adjust the depth of the seat as desired.









Qui e nelle pagine precedenti: divano e pouf Paris Seoul rivestimento sfoderabile in tessuto Kitami 04 sabbia, cuscini in velluto Persia 2006 prugna. Tavolino Paris Seoul in cuoio 02 nero e interno struttura in brown nickel opaco. Tavolini Tribeca con struttura in brown nickel opaco e piani in marmo emperador dark lucido. Composizione Wall System con struttura e inserti attrezzati in rovere spessart, ante Slim a ribalta laccato opaco visone.

This and previous pages: sofa and pouf Paris Seoul covered in removable fabric Kitami 04 sabbia, cushions in velvet Persia 2006 prugna. Paris Seoul coffee table in hide 02 nero and inner structure in mat brown nickel. Tribeca coffee tables with mat brown nickel structure and top in glossy marble emperador dark. Wall System bookcase with structure and accessorized inserts in spessart oak, visone mat lacquer Slim flap doors.







Qui e nella pagina precedente: divano e pouf Paris Seoul rivestimento sfoderabile in tessuto Rabat 403 tortora, cuscini in velluto Persia 26 nero. Il divano Paris Seoul è caratterizzato da un meccanismo che permette di variare la profondità della seduta in due diverse posizioni. A sinistra: dettaglio della seduta nella posizione più avanzata.

This and previous page: sofa and pouf Paris Seoul with removable cover in fabric Rabat 403 tortora, cushions in velvet Persia 26 nero. Paris Seoul sofa is distinguished by a mechanism, which allows changing the seat depth in two positions. Left: close up of the seating cushion in the moved forward position.



## PARIS SEOUL

Design Jean-Marie Massaud, 2012

Struttura e basamento in legno e derivati. Imbottitura schienale e braccioli in poliuretano flessibile stampato in doppia densità. Imbottitura cuscino seduta in poliuretano flessibile a quote differenziate e molle. Seduta con meccanismo per regolazione in profondità in due posizioni fisse. Prerivestimento in fibra di poliestere, tela cotone e piuma. Piedini in materiale plastico. Rivestimento sfoderabile in tessuto o pelle.

Structure and base in wood and wood by-products. Padding of backrest cushion and armrests in flexible moulded polyurethane with double density. Padding of seat cushion in multi-density flexible polyurethane and springs. Seat with mechanism to adjust the depth in two fixed positions. Pre-cover in polyester fibre, cotton canvas and down. Feet in plastic material. Removable cover in fabric or leather.

### Regolazione seduta Seat adjustment



posizione 1  
position 1



posizione 2  
position 2

### Terminale sx-dx Lt-rt end unit

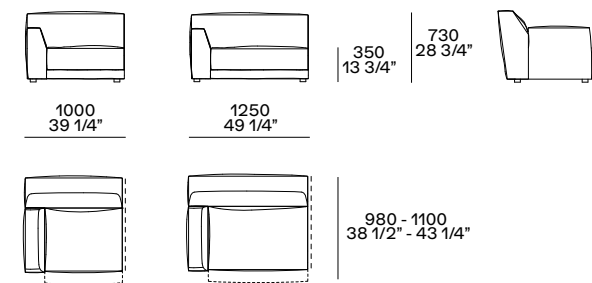

### Pouf centrostanza Freestanding pouf

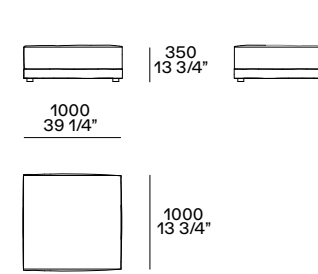

### Centrale Central unit

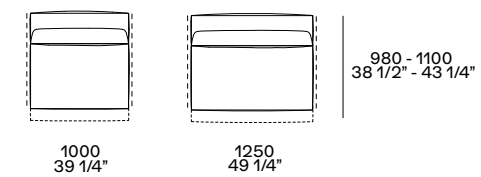

### Angolo sx-dx Lt-rt corner unit

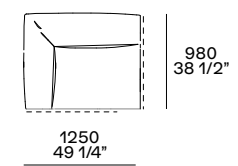

### Pouf terminale sx-dx Lt-rt end unit pouf

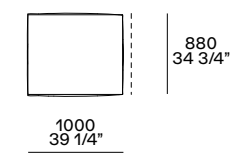

### Chaise longue terminale sx-dx Lt-rt end unit chaise longue

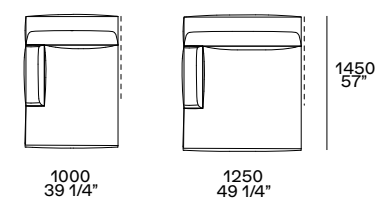

### Cuscini opzionali Optional cushions

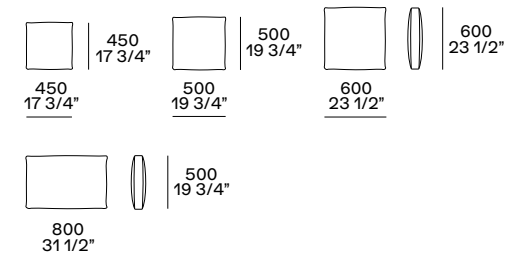

# ARMCHAIRS

Uno spazio personale in cui abbandonarsi al relax: la poltrona secondo Poliform. Pensata per la zona giorno ma ideale in tutti gli ambienti della casa votati al comfort, è la perfetta unione tra volumi pieni e imbottiture morbide che invitano alla seduta. Tessuti e pelli aggiungono piacevoli sensazioni tattili. I designer sono Jean-Marie Massaud, Marcel Wanders studio, Emmanuel Gallina, Vincent Van Duysen.

A personal space to indulge in relaxation: the armchair according to Poliform. Designed for the day area but ideal in all the environments of the house devoted to comfort, it is the perfect combination of full volumes and soft padding that invite you to the seat. Fabrics and leathers add pleasant tactile sensations. The designers are Jean-Marie Massaud, Marcel Wanders studio, Emmanuel Gallina, Vincent Van Duysen.

ARMCHAIRS	LE CLUB	283
	KAY LOUNGE	297
	MAD CHAIR	315
	MAD JOKER	330
	MAD QUEEN	336
	MAD KING	344
	MAD CHAISE LONGUE	346
	STANFORD	357
	STANFORD LOUNGE	368
	GENTLEMAN RELAX	377
	GENTLEMAN'S FRIENDS	384
	GENTLEMAN RESERVED	390
	GENTLEMAN SINGLE	394
	JANE	401
	JANE LARGE	412
	JANE LOUNGE	418
	SANTA MONICA	429
	SANTA MONICA LOUNGE	436
	SANTA MONICA HOME	442
	IPANEMA	451
	GASTON	461
	MARLON	469
	MARLON LOUNGE	476
	VENTURA LOUNGE	481
	WALLACE	491



# LE CLUB



Ispirata alle voluminose poltrone in cuoio dei club del secolo scorso, Le Club reinterpreta in chiave contemporanea uno degli archetipi del design. Nessun compromesso sul comfort né sulla qualità dell'esecuzione per una poltrona che alleggerisce le forme e i materiali, all'insegna di un'eleganza più disinvolta. Fra artigianalità e tecnologia, Le Club è destinata a non subire il passare del tempo, nuova icona di spazi domestici e luoghi istituzionali.

Inspired by the voluminous hide armchairs of the clubs of the last century, Le Club reinterprets one of the archetypes of design with a contemporary approach. No compromise on comfort nor on the quality of execution for an armchair that lightens the shapes and materials in the name of a more casual elegance. Between craftsmanship and technology, Le Club is destined to become timeless, a new icon of domestic spaces and institutional places.

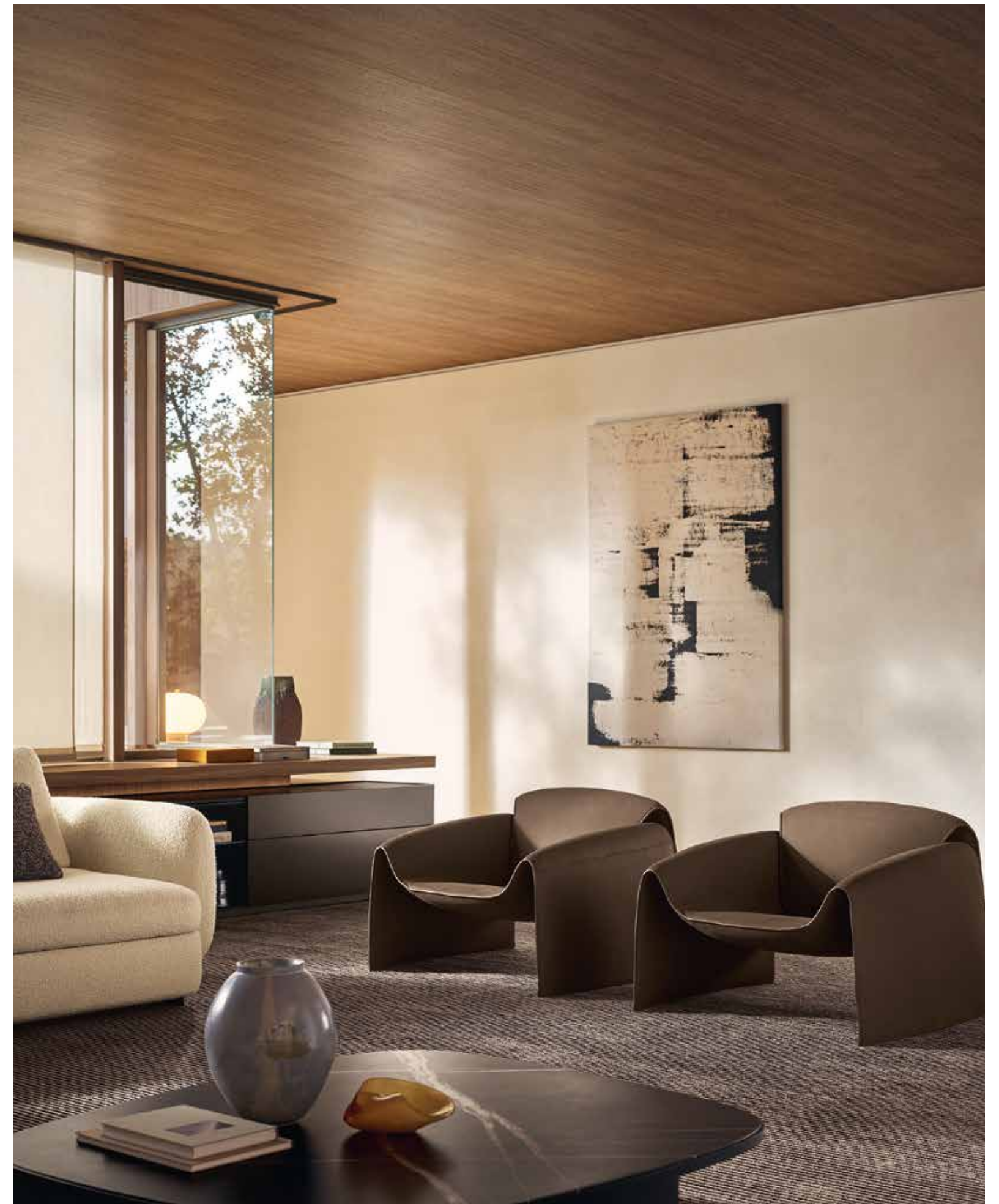



Qui e nella pagina precedente: poltrone Le Club in pelle non sfoderabile Silk 06 roccia. Tavolini Orbit, piano e struttura in vetro bronzato. Divano Saint-Germain in tessuto sfoderabile Siro 01 bianco, cuscini in tessuto Brest 11 cioccolato, velluto Persia 2002 bruciato e velluto Glasgow 01 crema, piedini brown nickel opaco. Tavolini Koishi, al centro con piani in marmo sahara noir levigato finitura poliestere, accanto al divano con piano in marmo zecevo levigato, tutti con struttura brunito opaco. Contenitori Code con vani a giorno in laccato opaco bronzo, cassetti e fianchi in laccato opaco visone, top retroilluminato in laccato opaco bronzo e zoccolino in ardesia opaco. Tappeto Cannelé.

This and previous page: Le Club armchairs in non-removable leather Silk 06 roccia. Orbit coffee tables, top and structure in bronzed glass. Saint-Germain sofa in removable fabric Siro 01 bianco, cushions in fabric Brest 11 cioccolato, velvet Persia 2002 bruciato and velvet Glasgow 01 crema, mat brown nickel feet. Orbit coffee tables, top and structure in bronzed glass. Koishi coffee tables, in the center with tops in mat marble sahara noir polyester finish, next to the sofa with top in mat marble zecevo, all with mat brunito structure. Code open storage units in mat lacquer bronzo, drawers and sides in mat lacquer visone, backlit top in mat lacquer bronzo and mat ardesia plinth. Carpet Cannelé.

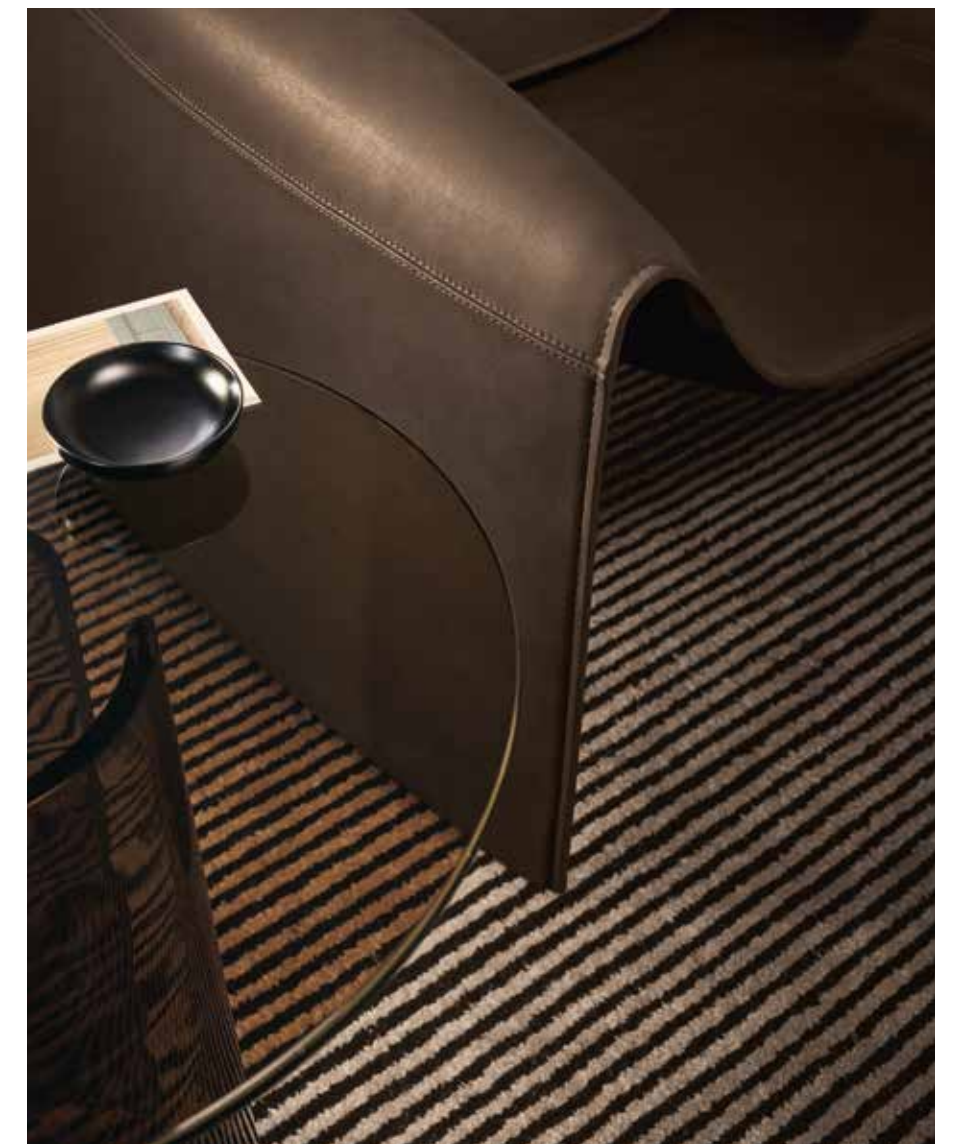

In questa pagina: poltrona e pouf Le Club con rivestimento non sfoderabile in pelle Silk 01 crema. Nella pagina successiva: poltrone Le Club con rivestimento non sfoderabile in tessuto Agadir 09 giada, pelle Silk 06 roccia e 01 crema.

This page: Le Club armchair and pouf with non-removable cover in leather Silk 01 crema. Next page: Le Club armchairs with non-removable cover in fabric Agadir 09 giada, leather Silk 06 roccia and 01 crema.





In questa pagina: poltrona Le Club con rivestimento non sfoderabile in tessuto Agadir 09 giada. Nella successiva: poltrone Le Club in pelle non sfoderabile Silk 01 crema. Tavolini Koishi con piani in marmo zecevo levigato e strutture verniciato champagne opaco. Libreria Lexington con montanti, ripiani e contenitori in rovere gold e champagne opaco. Tappeto Relief cammello.

This page: Le Club armchair with non-removable cover in fabric Agadir 09 giada. Next page: Le Club armchairs in non-removable leather Silk 01 crema. Koishi coffee tables with tops in mat marble zecevo and painted mat champagne structures. Lexington bookcase with uprights, shelves and storage units in gold oak and mat champagne. Carpet Relief cammello.





## LE CLUB

Design Jean-Marie Massaud, 2020

Struttura in acciaio con seduta sostenuta da cinghie elastiche e giunti di unione tra schienale e seduta in alluminio. Seduta in poliuretano flessibile stampato. Appoggio a terra con scivoli in materiale plastico trasparente. Rivestimento non sfoderabile in tessuto o pelle.

Structure in steel with seat supported by elastic belts and aluminium joints between backrest and seat. Seat in flexible moulded polyurethane. Floor support with chutes in transparent plastic material. Non-removable cover in fabric or leather.

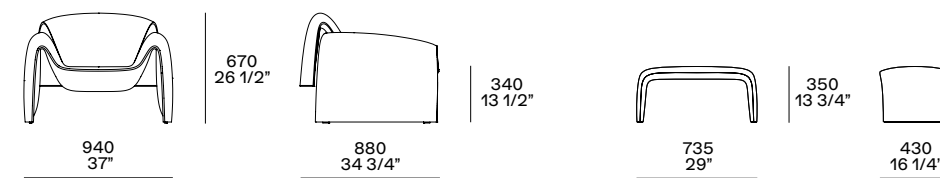



# KAY LOUNGE

Elegante, leggera ed essenziale, Kay Lounge è una poltrona dall'innata modernità. La struttura è in metallo, mentre la seduta è disponibile in pelle o cuoio. Da sola o in coppia, con il caratteristico poggiatesta, Kay Lounge è una poltrona che si fa notare in ogni contesto, dal più classico al più contemporaneo.

Elegant, light, and minimalistic, Kay Lounge is an armchair with an innate modernity. The structure is in metal, while the seat is available in leather or hide. Alone or paired, with the characteristic footrest, Kay Lounge is an armchair that stands out in every context, from the most classic to the most contemporary.







Qui e nella pagina precedente: poltrona e pouf Kay Lounge in pelle non sfoderabile Hairy bianco/nero, struttura in cromo satinato. Tavolino Nara in legno massello noce gold. Mensolone Code retroilluminato in laccato opaco granata. Divano Westside in tessuto sfoderabile Arcadia 02 sabbia, cuscini in velluto Tebe 06 giada, schienale mobile in cuoio 26 invecchiato e basamento in brown nickel opaco. Tappeto Tratto carbone.

This and previous page: Kay Lounge armchair and pouf in non-removable leather Hairy white/black, structure in brushed chrome. Nara coffee table in solid wood gold walnut. Code backlit thick shelf in mat lacquer granata. Westside sofa in removable fabric Arcadia 02 sabbia, cushions in velvet Tebe 06 giada, movable backrest in hide 26 invecchiato and mat brown nickel base. Carpet Tratto carbone.



In questa pagina: poltrona e pouf Kay Lounge con rivestimento non sfoderabile in pelle Silk 12 senape e struttura in cromo satinato.

This page: Kay Lounge armchair and pouf with non-removable cover in leather Silk 12 senape and brushed chrome structure.



In questa pagina: poltrona e pouf Kay Lounge con rivestimento non sfoderabile in cuoio intrecciato 02 nero, struttura in brown nickel opaco.

This page: Kay Lounge armchair and pouf with non-removable cover in woven hide 02 nero, mat brown nickel structure.

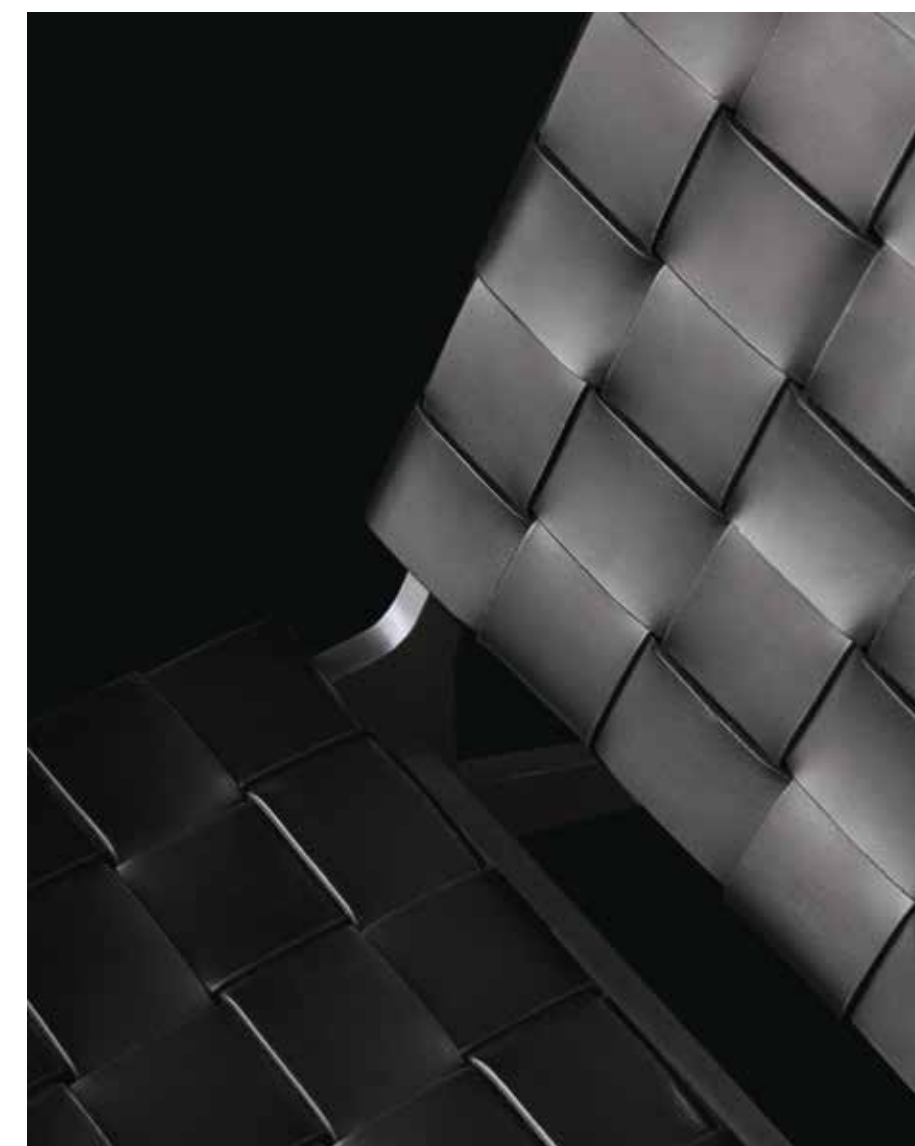



In questa pagina: poltrona e pouf Kay Lounge con rivestimento non sfoderabile in pelle Silk 06 roccia e struttura in cromo satinato. Sistema Code con boiserie in tessuto lino chiaro e laccato opaco canapa con profili champagne opaco, contenitori sospesi retroilluminati in laccato metallico ottone con top in marmo zecevo levigato. Tappeto Plain tortora.

This page: Kay Lounge armchair and pouf with non-removable cover in leather Silk 06 roccia and structure in brushed chrome. Code system with wall panelling in fabric lino chiaro and mat lacquer canapa with mat champagne profiles, backlit suspended storage units in metal lacquer ottone with top in mat marble zecevo. Carpet Plain tortora.



In questa pagina: poltrona Kay Lounge con rivestimento non sfoderabile in cuoio 02 nero e struttura in cromo satinato.

This page: Kay Lounge armchair with non-removable cover in hide 02 nero and brushed chrome structure.





Qui e nella pagina successiva: poltrona e pouf Kay Lounge con rivestimento non sfoderabile in pelle Hairy cappuccino, struttura in brown nickel opaco. Tavolino Dama in legno massello noce. Letto Jacqueline con testata e base imbottite, rivestimento sfoderabile in tessuto Lima 67 pernice e cuciture a cordoncino in colore nero, rulli in pelle sfoderabile Silk 10 terracotta. Tappeto Plain natural.

This and next page: Kay Lounge armchair and pouf with non-removable cover in leather Hairy cappuccino, mat brown nickel structure. Dama coffee table in solid wood walnut. Jacqueline bed with padded headboard and base, removable cover in fabric Lima 67 pernice and drawstring stitchings in black colour, roll cushions in removable leather Silk 10 terracotta. Carpet Plain natural.





## KAY LOUNGE

Design Jean-Marie Massaud, 2019

Struttura in metallo, finitura cromo satinato o verniciato brown nickel opaco.  
 Seduta e schienale in poliuretano flessibile stampato o cinghie elastiche solo per la versione in cuoio intrecciato.  
 Rivestimento non sfoderabile in pelle, pelle Hairy, cuoio colori o cuoio intrecciato colori.

Structure in metal, finish brushed chrome or painted mat brown nickel.  
 Seat and backrest in flexible moulded polyurethane or elastic belts only for the version in woven hide.  
 Non-removable cover in leather, Hairy leather, hide or woven hide in the sample colours.





# MAD COLLECTION



La collezione Mad si è evoluta a partire da Mad Chair, una poltrona dalle linee armoniche e avvolgenti, cui si sono aggiunte la poltrona con schienale alto e basamento girevole Mad Joker e la poltrona bassa Mad Queen, morbida e rassicurante. A completare la collezione disegnata da Marcel Wanders studio, Mad King e Mad Chaise Longue, due poltrone dal disegno asimmetrico, sinuose e invitanti.

The Mad collection has evolved starting from Mad Chair, an armchair with harmonious and enveloping lines, later accompanied by the armchair with high back and swivel base Mad Joker and the low Mad Queen armchair, soft and reassuring. To complete the collection designed by Marcel Wanders studio, Mad King and Mad Chaise Longue, two armchairs with an asymmetric design, sinuous and inviting.

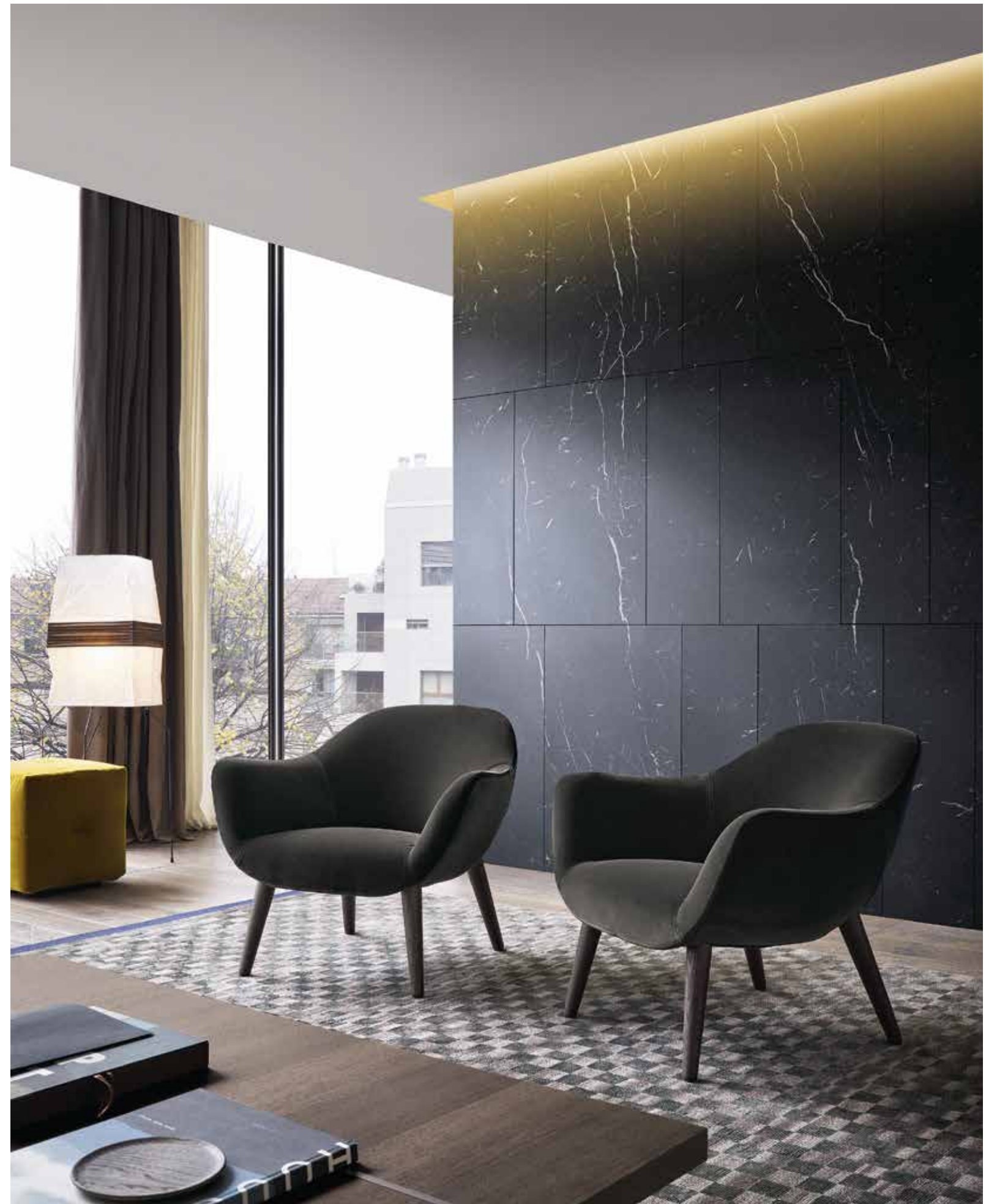



Nella pagina precedente: poltrone Mad Chair con rivestimento sfoderabile in velluto Persia 1404 carbone, gambe in rovere spessart. Pouf Onda in velluto non sfoderabile Persia 1403 ocra. Tavolino Bristol in rovere spessart. In questa pagina: poltrone Mad Chair con rivestimento sfoderabile in tessuto Nancy 125 sabbia, basamento girevole in brown nickel lucido. Tavolino Soori in metallo finitura bronzo anticato. Tavolino Dama in laccato lucido granata. Tappeto Frame perla.

Previous page: Mad Chair armchairs with removable cover in velvet Persia 1404 carbone, legs in spessart oak. Onda pouf in non-removable velvet Persia 1403 ocra. Bristol coffee table in spessart oak. This page: Mad Chair armchairs with removable cover in fabric Nancy 125 sabbia, swivel base in glossy brown nickel. Soori coffee table in metal with antique bronze finish. Dama coffee table in granata glossy lacquer. Carpet Frame perla.



In questa pagina: poltrona Mad Chair con rivestimento sfoderabile in tessuto Nancy 101 carbone, gambe in olmo nero.

This page: Mad Chair armchair with removable cover in fabric Nancy 101 carbone, legs in black elm.



In questa pagina: poltrona Mad Chair con rivestimento sfoderabile in velluto Persia 58 danubio, basamento girevole in champagne opaco.

This page: Mad Chair armchair with removable cover in velvet Persia 58 danubio, swivel base in mat champagne.



In questa pagina: poltrone Mad Chair con rivestimento sfoderabile in pelliccia Cashmere grigio, basamento girevole in brown nickel lucido. Tavolino Soori in metallo finitura bronzo anticato. Tappeto Frame carbone.

This page: Mad Chair armchairs with removable cover in fur Cashmere grigio, swivel base in glossy brown nickel. Soori coffee table in metal with antique bronze finish. Carpet Frame carbone.



In questa pagina: poltrona Mad Chair con rivestimento sfoderabile in pelliccia Cashmere bianco, gambe in rovere spessart.

This page: Mad Chair armchair with removable cover in fur Cashmere bianco, legs in spessart oak.





In questa pagina: poltrona Mad Chair con rivestimento sfoderabile in pelle Soft 14 oliva, basamento girevole in brown nickel lucido.

This page: Mad Chair armchair with removable cover in leather Soft 14 oliva, swivel base in glossy brown nickel.







Nella pagina precedente: poltrone Mad Joker e pouf Mad con rivestimento non sfoderabile, esterno in pelle Soft 14 oliva e interno in tessuto Sheffield 04 bronzo, basamento girevole in brown nickel lucido. Tavolini Dama in massello noce. Tappeto Plain natural. In questa pagina: poltrona Mad Joker e pouf Mad con rivestimento non sfoderabile, esterno in pelle Nabuk 02 tortora e interno in tessuto Argo 1001 bianco, basamento girevole in brown nickel lucido.

Previous page: Mad Joker armchairs and Mad pouf with non-removable cover, outer cover in leather Soft 14 oliva and inner cover in fabric Sheffield 04 bronzo, swivel base in glossy brown nickel. Dama coffee tables in solid walnut. Carpet Plain natural. This page: Mad Joker armchair and Mad pouf with non-removable cover, outer cover in leather Nabuk 02 tortora and inner cover in fabric Argo 1001 bianco, swivel base in glossy brown nickel.





In questa pagina: poltrona Mad Joker con rivestimento non sfoderabile, esterno in tessuto Naxos 08 antracite e interno in tessuto Sendai 04 lavagna, gambe in olmo nero.

This page: Mad Joker armchair with non-removable cover, outer cover in fabric Naxos 08 antracite and inner cover in fabric Sendai 04 lavagna, legs in black elm.





Nella pagina precedente: poltrone Mad Queen con rivestimento sfoderabile, esterno in tessuto Naxos 08 antracite e interno in tessuto Gibson matelassé 07 grafite, gambe in olmo nero. In questa pagina: poltrona Mad Queen con rivestimento sfoderabile, esterno in pelle Soft 11 cioccolato e interno in tessuto Nancy 125 sabbia, gambe in olmo nero.

Previous page: Mad Queen armchairs with removable cover, outer cover in fabric Naxos 08 antracite and inner cover in fabric Gibson matelassé 07 grafite, legs in black elm. This page: Mad Queen armchair with removable cover, outer cover in leather Soft 11 cioccolato and inner cover in fabric Nancy 125 sabbia, legs in black elm.





In questa pagina: poltrone Mad Queen con rivestimento sfoderabile in tessuto Caleo 01 bianco, gambe in rovere spessart. Nella pagina successiva: poltrone Mad Queen con rivestimento sfoderabile, esterno e gambe in pelle Nabuk 01 latte, interno in tessuto Agadir 01 sabbia.

This page: Mad Queen armchairs with removable cover in fabric Caleo 01 bianco, legs in spessart oak. Next page: Mad Queen armchairs with removable cover, outer cover and legs in leather Nabuk 01 latte, inner cover in fabric Agadir 01 sabbia.





In questa pagina: poltrona Mad King con rivestimento sfoderabile, esterno e gambe in pelle Soft 06 cemento, interno in tessuto Kitami 03 acciaio. Nella successiva: Mad Chaise Longue con rivestimento non sfoderabile, esterno in pelle Nabuk 08 prussia, interno in tessuto Kushiro 11 notte, gambe in olmo nero.

This page: Mad King armchair with removable cover, outer cover and legs in leather Soft 06 cemento, inner cover in fabric Kitami 03 acciaio. Next page: Mad Chaise Longue with non-removable cover, outer cover in leather Nabuk 08 prussia, inner cover in fabric Kushiro 11 notte, black elm legs.









In questa pagina: poltrona Mad King con rivestimento sfoderabile, esterno in pelle Nabuk 01 latte, interno in tessuto Itaca 309 cipria, gambe in rovere spessart.

This page: Mad King armchair with removable cover, outer cover in leather Nabuk 01 latte, inner cover in fabric Itaca 309 cipria, spessart oak legs.



In questa pagina: poltrona Mad King con rivestimento sfoderabile, esterno in tessuto Caleo 15 bordeaux e interno in tessuto Gibson matelassé 23 rubino, gambe e vassoio opzionale in rovere spessart. A parete bacheca Quid laccato opaco piombo con schienali laccato opaco carbone, cassetti in cuoio 02 nero con maniglie in brown nickel lucido. Sotto: dettaglio del vassoio per la versione Mad King con un bracciolo.

This page: Mad King armchair with removable cover, outer cover in fabric Caleo 15 bordeaux and inner cover in fabric Gibson matelassé 23 rubino, legs and optional tray in spessart oak. Wall mounted Quid open display case mat lacquered piombo with carbone mat lacquered backs, drawers in hide 02 nero with glossy brown nickel handles. Below: close up of the tray for the version Mad King with one armrest.



## MAD COLLECTION

Design Marcel Wanders studio

### Mad Chair, 2014

Scocca in poliuretano flessibile stampato con parti in poliuretano flessibile a quote differenziate, priverivestimento in fibra di poliestere. Rivestimento sfoderabile in tessuto, pelle o pelliccia Cashmere. Possibilità di rivestimento diverso tra interno ed esterno della scocca, rivestimento sfoderabile ma non lavabile se il tessuto viene abbinato a una pelle. Il rivestimento Gibson matelassé è disponibile solo per la scocca interna. Gambe in rovere spessart e olmo nero o basamento girevole con ritorno in metallo verniciato champagne opaco o brown nickel opaco e lucido. Cuscino salvareni opzionale con rivestimento sfoderabile in tessuto o pelle.

Body in flexible moulded polyurethane with parts in multy-density flexible polyurethane, pre-cover in polyester fibre. Removable cover in fabric, leather or fur Cashmere. The inner and outer cover of the body can be in two different materials, the cover is removable but not washable in case of combination of fabric and leather. Fabric Gibson matelassé is available only for the inner cover. Legs in spessart oak and black elm or swivel base with automatic returning mechanism in mat champagne or mat and glossy brown nickel painted metal. Optional lower back cushion with removable cover in fabric or leather.

#### gambe in essenza legs in wood

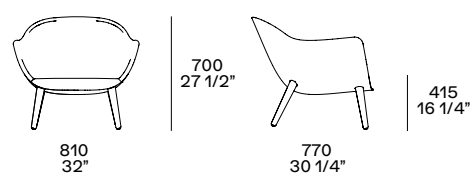

due braccioli  
two armrests

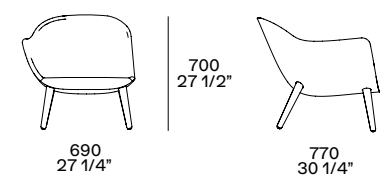

bracciolo sinistro  
left arm

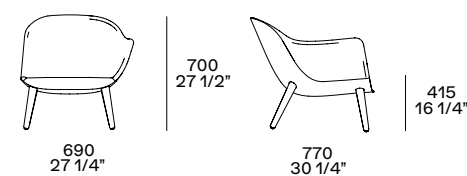

bracciolo destro  
right arm

#### basamento girevole swivel base

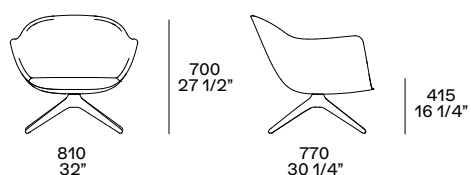

due braccioli  
two armrests

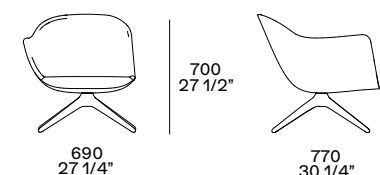

bracciolo sinistro  
left arm

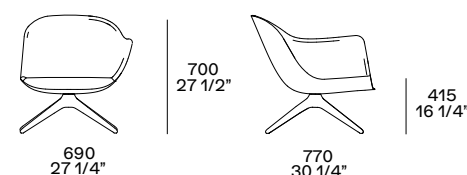

bracciolo destro  
right arm

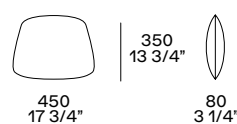

cuscino salvareni opzionale  
optional lower back cushion

### Mad Joker, 2016

Scocca in poliuretano flessibile stampato con parti in poliuretano flessibile a quote differenziate, priverivestimento in fibra di poliestere. Rivestimento non sfoderabile in tessuto o pelle. Possibilità di rivestimento diverso tra interno ed esterno della scocca. Gambe in rovere spessart e olmo nero o basamento girevole con ritorno in metallo verniciato champagne opaco o brown nickel opaco e lucido.

Body in flexible moulded polyurethane with parts in multy-density flexible polyurethane, pre-cover in polyester fibre. Non-removable cover in fabric or leather. The inner and outer cover of the body can be in two different materials. Legs in spessart oak and black elm or swivel base with automatic returning mechanism in mat champagne or mat and glossy brown nickel painted metal.

#### gambe in essenza legs in wood

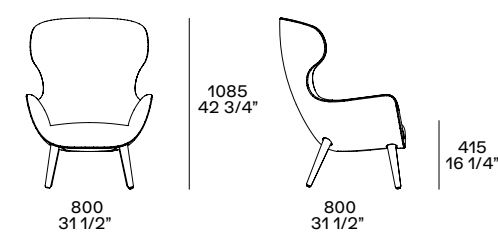

#### basamento girevole swivel base

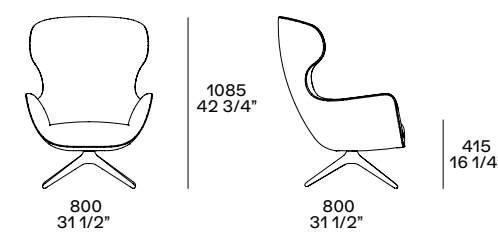

### Mad Pouf, 2017

Seduta in poliuretano flessibile stampato, priverivestimento in fibra di poliestere. Rivestimento sfoderabile in tessuto o pelle. Possibilità di rivestimento diverso tra interno ed esterno della scocca, rivestimento sfoderabile ma non lavabile se il tessuto viene abbinato a una pelle. Basamento fisso in metallo verniciato champagne opaco o brown nickel opaco e lucido.

Seat in flexible moulded polyurethane, pre-cover in polyester fibre. Removable cover in fabric or leather. The inner and outer cover of the body can be in two different materials, the cover is removable but not washable in case of combination of fabric and leather. Fixed base in mat champagne or mat and glossy brown nickel painted metal.

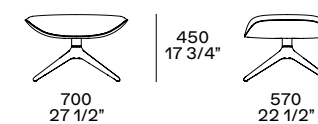

basamento fisso  
fixed base

## MAD COLLECTION

Design Marcel Wanders studio

### Mad Queen, 2015

Scocca e seduta in poliuretano flessibile stampato con parti in poliuretano flessibile a quote differenziate, prerivestimento in fibra di poliestere. Rivestimento sfoderabile in tessuto o pelle. Possibilità di rivestimento diverso tra interno ed esterno della scocca, rivestimento sfoderabile ma non lavabile se il tessuto viene abbinato a una pelle. Il rivestimento Gibson matelassé è disponibile solo per la scocca interna. Gambe in rovere spessart e olmo nero o rivestite come l'esterno della scocca.

Body and seat in flexible moulded polyurethane with parts in multi-density flexible polyurethane, pre-cover in polyester fibre. Removable cover in fabric or leather. The inner and outer cover of the body can be in two different materials, the cover is removable but not washable in case of combination of fabric and leather. Fabric Gibson matelassé is available only for the inner cover. Legs in spessart oak and black elm, or in the same material of the outer cover.

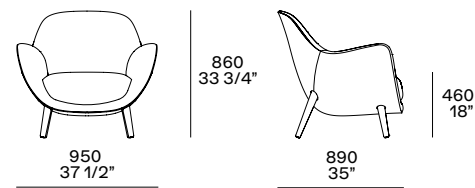

### Mad Chaise Longue, 2016

Scocca e seduta in poliuretano flessibile stampato con parti in poliuretano flessibile a quote differenziate, prerivestimento in fibra di poliestere. Rivestimento non sfoderabile in tessuto o pelle. Possibilità di rivestimento diverso tra interno ed esterno della scocca. Il rivestimento Gibson matelassé è disponibile solo per la scocca interna. Gambe in rovere spessart e olmo nero o rivestite come l'esterno della scocca.

Body and seat in flexible moulded polyurethane with parts in multi-density flexible polyurethane, pre-cover in polyester fibre. Non-removable cover in fabric or leather. The inner and outer cover of the body can be in two different materials. Fabric Gibson matelassé is available only for the inner cover. Legs in spessart oak and black elm or in the same material of the outer cover.

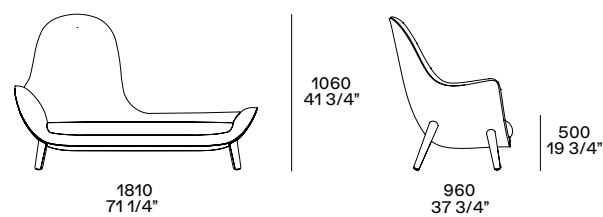

### Mad King, 2015

Scocca e seduta in poliuretano flessibile stampato con parti in poliuretano flessibile a quote differenziate, prerivestimento in fibra di poliestere. Rivestimento sfoderabile in tessuto o pelle. Possibilità di rivestimento diverso tra interno ed esterno della scocca, rivestimento sfoderabile ma non lavabile se il tessuto viene abbinato a una pelle. Il rivestimento Gibson matelassé è disponibile solo per la scocca interna. Gambe in rovere spessart e olmo nero o rivestite come l'esterno della scocca. La versione con un bracciolo è disponibile con o senza vassoio, nelle finiture rovere spessart o olmo nero.

Body and seat in flexible moulded polyurethane with parts in multi-density flexible polyurethane, pre-cover in polyester fibre. Removable cover in fabric or leather. The inner and outer cover of the body can be in two different materials, the cover is removable but not washable in case of combination of fabric and leather. Fabric Gibson matelassé is available only for the inner cover. Legs in spessart oak and black elm, or in the same material of the outer cover. The version with one armrest is available with or without tray, in the finishes spessart oak or black elm.

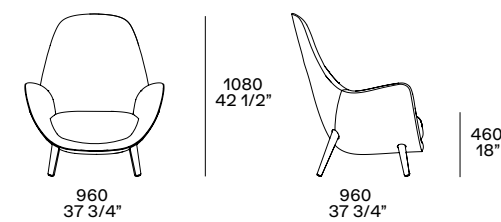

due braccioli  
two armrests

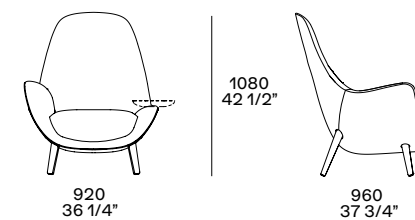

bracciolo sinistro  
left arm

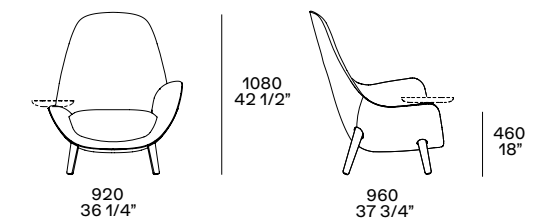

bracciolo destro  
right arm

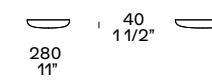

vassoio  
tray

# STANFORD COLLECTION

Sintesi e leggerezza sono i capisaldi della naturale eleganza della collezione Stanford. Sulla base girevole in metallo si ergono linee rigorose, che si smussano nella poltrona con schienale alto Stanford Lounge. Particolare il rivestimento, con esterno in cuoio e interno in pelle tono su tono, con cuscino di seduta in pelle.

Synthesis and lightness are the cornerstones of the natural elegance of the Stanford collection. On the swivel metal base stand rigorous lines, which get smoothed in the high-back armchair Stanford Lounge. The padding is particular, with hard leather exterior and tone-on-tone leather interior, with leather seat cushion.

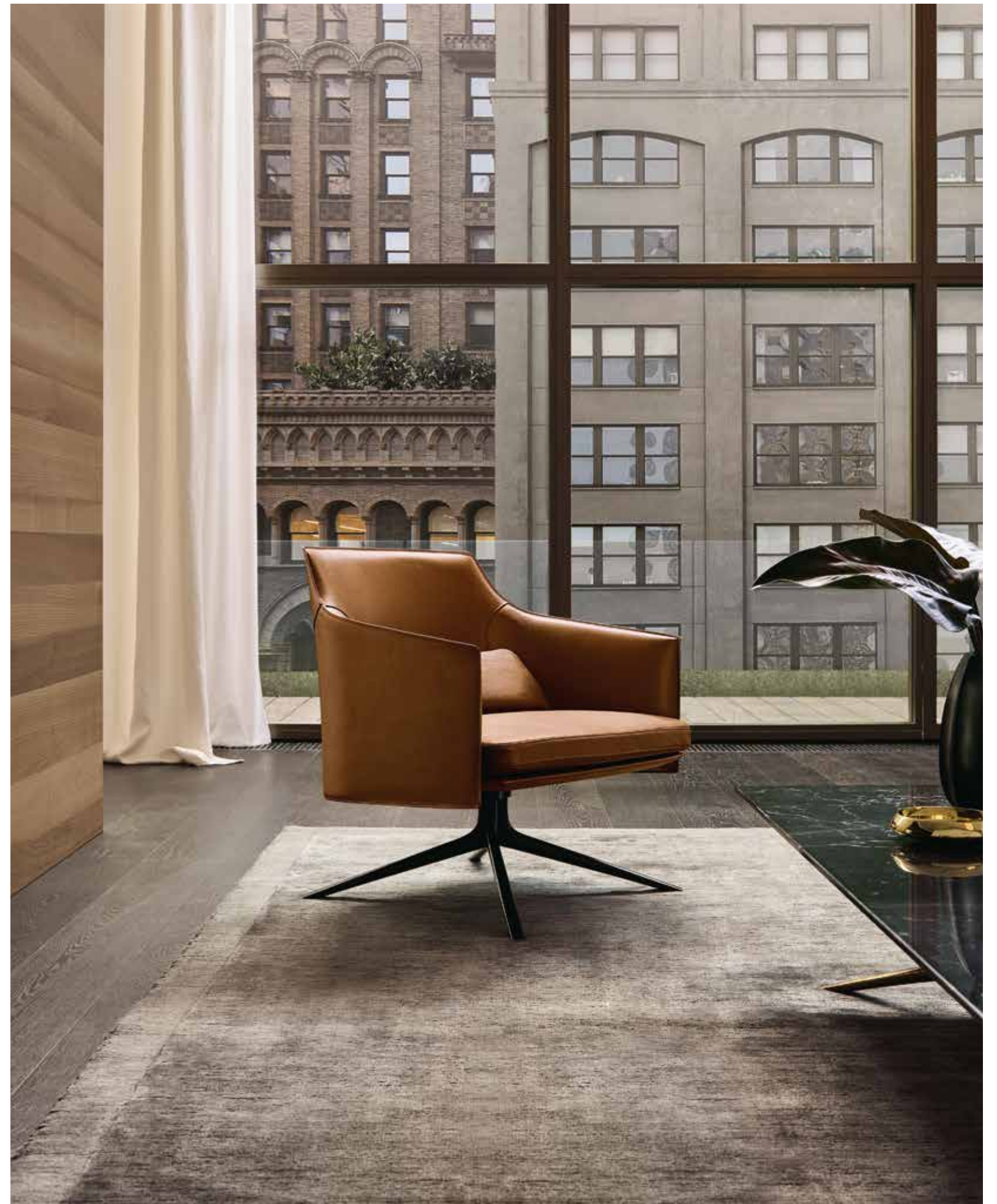



Qui e nelle pagine precedenti: poltrone Stanford con rivestimento non sfoderabile, esterno in cuoio 26 invecchiato, interno e cuscino della seduta in pelle Soft 04 cognac, basamento girevole in brown nickel lucido. Cuscino salvareni opzionale con rivestimento sfoderabile in pelle Soft 04 cognac. Tavolino Mondrian piano in marmo noir saint laurent lucido e struttura in fusione di bronzo lucidata oro. Tappeto Frame grey.

This and previous pages: Stanford armchairs with non-removable cover, outer cover in hide 26 invecchiato, inner cover and seat cushion in leather Soft 04 cognac, swivel base in glossy brown nickel. Optional lower back cushion with removable cover in leather Soft 04 cognac. Mondrian coffee table with top in glossy marble noir saint laurent and structure in gold polished bronze casting. Carpet Frame grey.



In questa pagina: poltrona Stanford con rivestimento non sfoderabile, esterno in cuoio 02 nero, interno e cuscino della seduta in pelle Soft 13 carbone, basamento girevole in brown nickel lucido. Cuscino salvareni opzionale con rivestimento sfoderabile in pelle Soft 13 carbone.

This page: Stanford armchair with non-removable cover, outer cover in hide 02 nero, inner cover and seat cushion in leather Soft 13 carbone, swivel base in glossy brown nickel. Optional lower back cushion with removable cover in leather Soft 13 carbone.







In questa pagina: poltrona Stanford con rivestimento non sfoderabile, esterno in cuoio 29 tortora, interno e cuscino della seduta in pelle Soft 02 mastice, basamento girevole in brown nickel lucido.

This page: Stanford armchair with non-removable cover, outer cover in hide 29 tortora, inner cover and seat cushion in leather Soft 02 mastice, swivel base in glossy brown nickel.



In questa pagina: poltrone Stanford con rivestimento non sfoderabile in tessuto Orleans 12 carbone, basamento girevole in brown nickel lucido. Tavolino Soori in metallo finitura bronzo anticato. Cassettera Abbinabili in rovere spessart.

This page: Stanford armchairs with non-removable cover in fabric Orleans 12 carbone, swivel base in glossy brown nickel. Soori coffee table in metal with antique bronze finish. Abbinabili chest of drawers in spessart oak.



In questa pagina: poltrona Stanford Lounge con rivestimento non sfoderabile, esterno in cuoio 19 caffè, interno e cuscino della seduta in pelle Soft 12 moka, basamento girevole in brown nickel lucido.

This page: Stanford Lounge armchair with non-removable cover, outer cover in hide 19 caffè, inner cover and seat cushion in leather Soft 12 moka, swivel base in glossy brown nickel.





In questa pagina: poltrona Stanford Lounge con rivestimento non sfoderabile in tessuto Kitami 04 sabbia, basamento girevole in champagne opaco. Cuscino salvareni opzionale con rivestimento sfoderabile in tessuto Kitami 04 sabbia.

This page: Stanford Lounge armchair with non-removable cover in fabric Kitami 04 sabbia, swivel base in mat champagne. Optional lower back cushion with removable cover in fabric Kitami 04 sabbia.



In questa pagina: poltrone Stanford Lounge con rivestimento non sfoderabile, esterno in cuoio 02 nero, interno e cuscino della seduta in pelle Soft 13 carbone, basamento girevole in brown nickel lucido. Tavolino Soori in metallo finitura bronzo anticato. Tappeto Plain natural.

This page: Stanford Lounge armchairs with non-removable cover, outer cover in hide 02 nero, inner cover and seat cushion in leather Soft 13 carbone, swivel base in glossy brown nickel. Soori coffee table in metal with antique bronze finish. Carpet Plain natural.



## STANFORD COLLECTION

Design Jean-Marie Massaud, 2016

### Stanford

Scocca in poliuretano compatto con inserto parte interna in poliuretano flessibile. Sottosedile in poliuretano compatto, cuscino seduta in poliuretano flessibile a quote differenziate e prriverestimento in ovatta di poliestere. Rivestimento non sfoderabile in tessuto, pelle o esterno scocca e sottosedile in cuoio colori e interno in pelle Soft. Basamento girevole con ritorno in fusione d'alluminio verniciato champagne opaco o brown nickel opaco e lucido. Cuscino salvareni opzionale in poliuretano stampato, prriverestimento parti in tela cotone con piuma e parti in ovatta di poliestere accoppiata, rivestimento sfoderabile in tessuto o pelle.

Body in compact polyurethane with inlay in flexible polyurethane. Seat in compact polyurethane with seat cushion in multi-density flexible polyurethane, pre-cover in polyester wadding. Non-removable cover in fabric, leather or outer body and seat in hide colours and inner in leather Soft. Swivel base with automatic returning mechanism in aluminium casting painted mat champagne or mat and glossy brown nickel. Optional lower back cushion in moulded polyurethane, pre-cover with parts in cotton canvas with down and parts in polyester wadding, removable cover in fabric or leather.

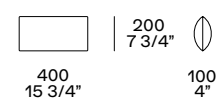
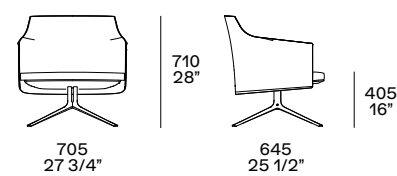

cuscino salvareni opzionale  
optional lower back cushion

### Stanford Lounge

Scocca in poliuretano compatto con inserto parte interna in poliuretano flessibile. Sottosedile in poliuretano compatto, cuscino seduta in poliuretano flessibile a quote differenziate e prriverestimento in ovatta di poliestere. Rivestimento non sfoderabile in tessuto, pelle o esterno scocca e sottosedile in cuoio colori e interno in pelle Soft. Basamento girevole con ritorno in fusione d'alluminio verniciato champagne opaco o brown nickel opaco e lucido. Cuscino salvareni opzionale in poliuretano stampato, prriverestimento parti in tela cotone con piuma e parti in ovatta di poliestere accoppiata, rivestimento sfoderabile in tessuto o pelle.

Body in compact polyurethane with inlay in flexible polyurethane. Seat in compact polyurethane with seat cushion in multi-density flexible polyurethane, pre-cover in polyester wadding. Non-removable cover in fabric, leather or outer body and seat in hide colours and inner in leather Soft. Swivel base with automatic returning mechanism in aluminium casting painted mat champagne or mat and glossy brown nickel. Optional lower back cushion in moulded polyurethane, pre-cover with parts in cotton canvas with down and parts in polyester wadding, removable cover in fabric or leather.

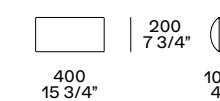
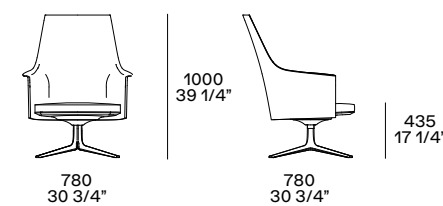

cuscino salvareni opzionale  
optional lower back cushion



# GENTLEMAN COLLECTION

Disegnata da Marcel Wanders studio, la collezione Gentleman è composta da divano fisso, pouf e tre poltrone di diverse dimensioni – compatta Gentleman Single, morbida e accogliente Gentleman Relax, fuori del comune Gentleman Reserved, con schienale alto. Una collezione di sedute dal comfort ineguagliabile, da usare singolarmente o tutte insieme.

Designed by Marcel Wanders studio, the Gentleman collection consists of a fixed sofa, ottoman, and three armchairs of different sizes – compact Gentleman Single, soft and cosy Gentleman Relax, outside-the-box Gentleman Reserved, with a tall backrest. A collection of seats with unparalleled comfort, to be used individually or all together.







Nelle pagine precedenti: poltrone Gentleman Relax e pouf Gentleman in tessuto sfoderabile Siro 02 lino, divano Gentleman's Friends in velluto sfoderabile Tebe 08 notte, basamento in brown nickel lucido. Tavolini Soori in metallo finitura bronzo anticato. Madia Code in noce gold, vano a giorno con schienale in specchio bronzo e luce a led integrata, basamento con piedini in champagne opaco. Composizione sospesa Code con mensolone retroilluminato in laccato metallico ottone, boiserie in laccato opaco canapa con profili in champagne opaco, libreria in laccato opaco ottone. Tappeto Plain tortora. In questa pagina: poltrona Gentleman Relax e pouf Gentleman con rivestimento sfoderabile in pelle Soft 03 nocciola, basamento in brown nickel opaco.

Previous pages: Gentleman Relax armchairs and Gentleman pouf in removable fabric Siro 02 lino, Gentleman's Friends sofa in removable velvet Tebe 08 notte, glossy brown nickel base. Soori coffee tables in metal with antique bronze finish. Code sideboard in gold walnut, open compartment with back in bronzed mirror and integrated led light, base with feet in mat champagne. Wall mounted Code composition with backlit thick shelf in metal lacquer ottone, wall panelling in mat lacquer canapa with mat champagne profiles, bookcase in mat lacquer ottone. Carpet Plain tortora. This page: Gentleman Relax armchair and Gentleman pouf with removable cover in leather Soft 03 nocciola, mat brown nickel base.

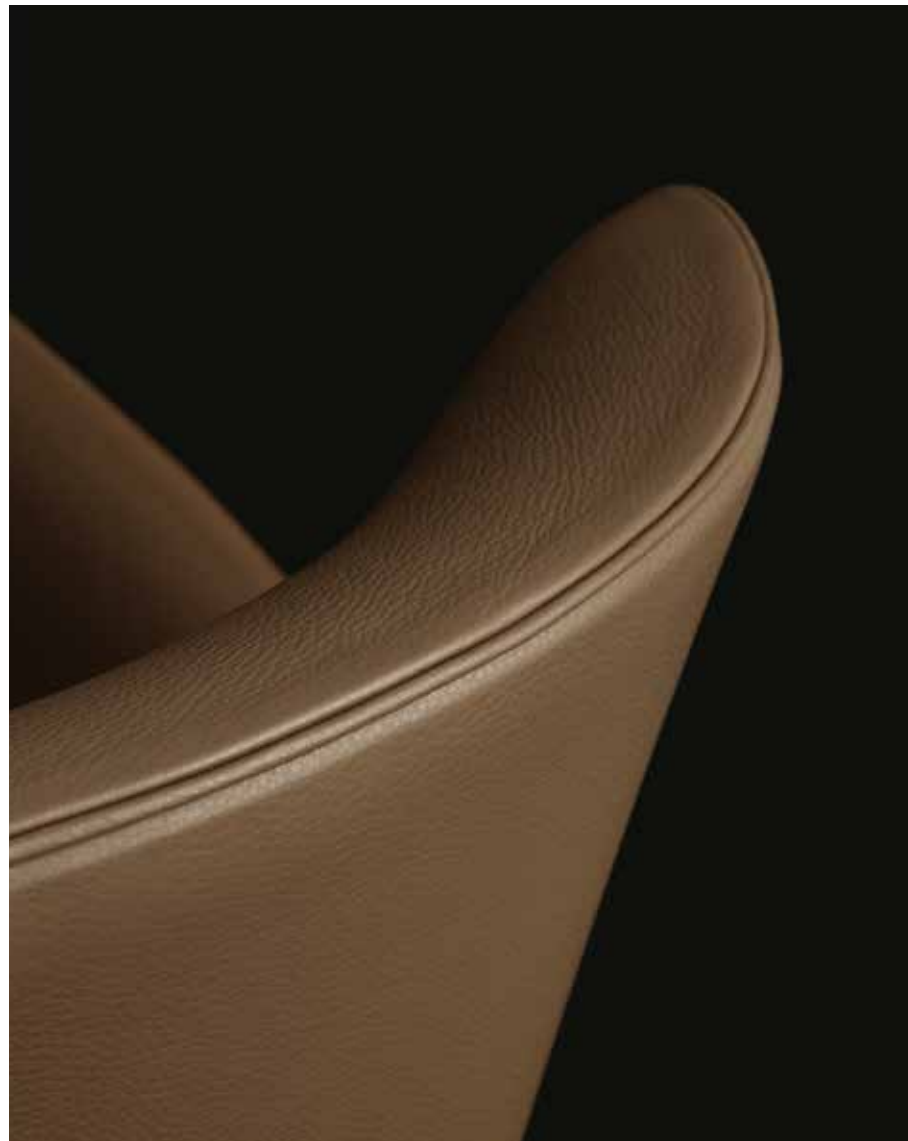





Nella pagina precedente: divano Gentleman's Friends con rivestimento sfoderabile in tessuto Arcadia 05 bronzo, cuscini in velluto Persia 1404 carbone con bordura gros-grain acciaio, basamento in brown nickel lucido. In questa pagina: poltrona Gentleman Relax con rivestimento sfoderabile in tessuto Antea 10 grafite con bordura gros-grain nero, basamento in champagne opaco.

Previous page: Gentleman's Friends sofa with removable cover in fabric Arcadia 05 bronzo, cushions in velvet Persia 1404 carbone with grosgrain piping acciaio, glossy brown nickel base. This page: Gentleman Relax armchair with removable cover in fabric Antea 10 grafite with grosgrain piping nero, base in mat champagne.



In questa pagina: poltrona Gentleman Relax in tessuto sfoderabile Siro 02 lino e basamento in brown nickel lucido. Pouf Saint-Germain in pelle sfoderabile Nabuk 06 mastice, piedini brown nickel opaco. Boiserie Code in tessuto lino bruciato con profili in champagne opaco. Tappeto Cannelé.

This page: Gentleman Relax armchair in removable fabric Siro 02 lino and base in glossy brown nickel. Saint-Germain pouf in removable leather Nabuk 06 mastice, mat brown nickel feet. Code wall panelling in fabric lino bruciato with mat champagne profiles. Carpet Cannelé.

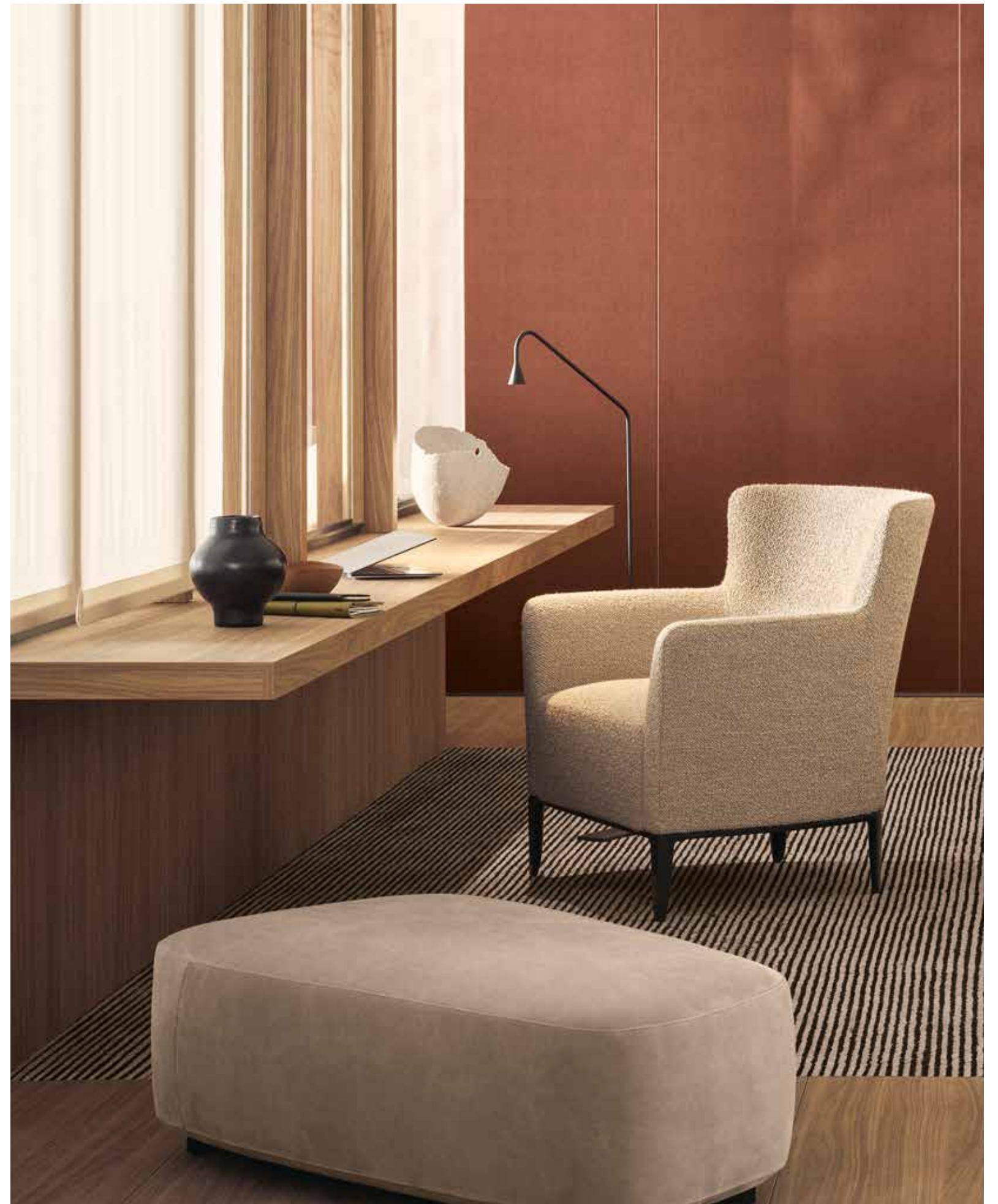



In questa pagina: poltrona Gentleman Reserved con cuscino salvareni e pouf Gentleman in pelle sfoderabile Silk 10 terracotta, basamento in champagne opaco. Tappeto Plain natural.

This page: Gentleman Reserved armchair with lower back cushion and Gentleman pouf in removable leather Silk 10 terracotta, base in mat champagne. Carpet Plain natural.

In questa pagina: poltrona Gentleman Reserved con rivestimento sfoderabile, esterno in pelle Nabuk 02 tortora, interno in tessuto Micene 03 sabbia, cuscino salvareni e bottoni in pelle Nabuk 02 tortora, basamento in brown nickel lucido. Pouf Gentleman con rivestimento sfoderabile in tessuto Micene 03 sabbia e pelle Nabuk 02 tortora, basamento in brown nickel lucido.

This page: Gentleman Reserved armchair with removable cover, outer cover in leather Nabuk 02 tortora, inner cover in fabric Micene 03 sabbia, lower back cushion and buttons in leather Nabuk 02 tortora, base in glossy brown nickel. Gentleman pouf with removable cover in fabric Micene 03 sabbia and leather Nabuk 02 tortora, glossy brown nickel base.



In questa pagina: poltrona Gentleman Single con rivestimento sfoderabile in pelle Silk 12 senape, basamento in brown nickel lucido.

This page: Gentleman Single armchair with removable cover in leather Silk 12 senape, base in glossy brown nickel.





In questa pagina: poltrona Gentleman Single in tessuto sfoderabile Kitami 04 sabbia con bordura gros-grain sahara e basamento in brown nickel lucido. Tavolino Dama in legno massello noce.

This page: Gentleman Single armchair in removable fabric Kitami 04 sabbia with grosgrain piping sahara and glossy brown nickel base. Dama coffee table in solid wood walnut.



## GENTLEMAN COLLECTION

Design Marcel Wanders studio, 2019

### Gentleman Single

Scocca e seduta in poliuretano flessibile stampato con parti in poliuretano flessibile a quote differenziate. Prerivestimento in fibra di poliestere. Basamento in metallo verniciato champagne opaco, brown nickel opaco o lucido. Rivestimento sfoderabile in tessuto o pelle. Bordura gros-grain nei colori da campionario.

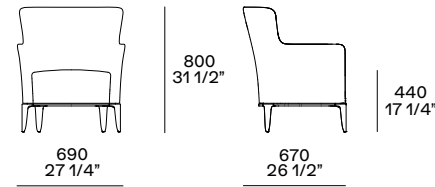

Body and seat in flexible moulded polyurethane with parts in differentiated-density flexible polyurethane. Pre-cover in polyester fibre. Base in painted metal mat champagne, mat or glossy brown nickel. Removable cover in fabric or leather. Grosgrain border in the sample colours.

### Gentleman Relax

Scocca e seduta in poliuretano flessibile stampato con parti in poliuretano flessibile a quote differenziate. Prerivestimento in fibra di poliestere. Basamento in metallo verniciato champagne opaco, brown nickel opaco o lucido. Rivestimento sfoderabile in tessuto o pelle. Bordura gros-grain nei colori da campionario.

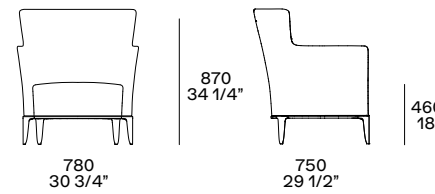

Body and seat in flexible moulded polyurethane with parts in differentiated-density flexible polyurethane. Pre-cover in polyester fibre. Base in painted metal mat champagne, mat or glossy brown nickel. Removable cover in fabric or leather. Grosgrain border in the sample colours.

### Gentleman Pouf

Seduta in poliuretano flessibile stampato con parti in poliuretano flessibile a quote differenziate. Prerivestimento in fibra di poliestere. Basamento in metallo verniciato champagne opaco, brown nickel opaco o lucido. Rivestimento sfoderabile in tessuto o pelle. Possibilità di rivestimento diverso tra la seduta e la fascia perimetrale.

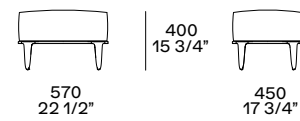

Seat in flexible moulded polyurethane with parts in differentiated-density flexible polyurethane. Pre-cover in polyester fibre. Base in painted metal mat champagne, mat or glossy brown nickel. Removable cover in fabric or leather. Possibility of different cover for seat cushion and perimeter band.

### Gentleman Reserved

Scocca e seduta in poliuretano flessibile stampato con parti in poliuretano flessibile a quote differenziate. Prerivestimento in fibra di poliestere. Basamento in metallo verniciato champagne opaco, brown nickel opaco o lucido. Rivestimento sfoderabile in tessuto o pelle. Schienale con due bottoni rivestiti. Bordura gros-grain nei colori da campionario. Possibilità di rivestimento diverso tra interno ed esterno della scocca, rivestimento sfoderabile ma non lavabile se il tessuto viene abbinato a una pelle, bottoni finitura a scelta tra rivestimento esterno o interno. Cuscino salvareni opzionale con rivestimento sfoderabile in tessuto o pelle.

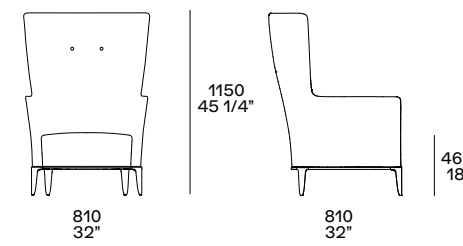

Body and seat in flexible moulded polyurethane with parts in differentiated-density flexible polyurethane. Pre-cover in polyester fibre. Base in painted metal mat champagne, mat or glossy brown nickel. Removable cover in fabric or leather. Back with two covered buttons. Grosgrain border in the sample colours. The inner and outer cover of the body can be in two different materials, the cover is removable but not washable in case of combination of fabric and leather, buttons finish to be chosen between outer or inner cover. Optional lower back cushion with removable cover in fabric or leather.

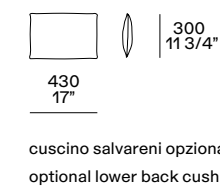

cuscino salvareni opzionale  
optional lower back cushion

### Gentleman's Friends

Scocca e seduta in poliuretano flessibile stampato con parti in poliuretano flessibile a quote differenziate. Prerivestimento in fibra di poliestere. Basamento in metallo verniciato champagne opaco, brown nickel opaco o lucido. Rivestimento sfoderabile in tessuto o pelle. Bordura gros-grain nei colori da campionario. Cuscino opzionale con rivestimento sfoderabile in tessuto o pelle.

Body and seat in flexible moulded polyurethane with parts in differentiated-density flexible polyurethane. Pre-cover in polyester fibre. Base in painted metal mat champagne, mat or glossy brown nickel. Removable cover in fabric or leather. Grosgrain border in the sample colours. Optional cushion with removable cover in fabric or leather.

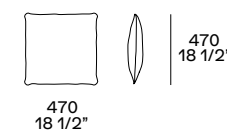
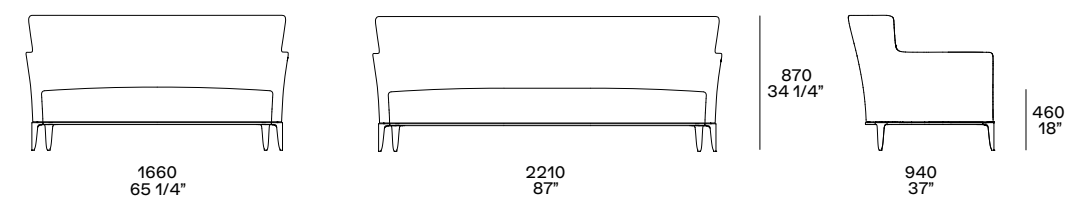

cuscino opzionale  
optional cushion



# JANE COLLECTION

La collezione Jane è ispirata all'idea di ambienti eleganti nei quali ritagliare spazi dedicati a comfort e intimità. L'omonima poltrona dalle dimensioni contenute, morbida e compatta, esprime uno stile contemporaneo e senza tempo. Le stesse armoniose proporzioni si ritrovano nei volumi più generosi del divanetto, di Jane Large e di Jane Lounge, e nelle declinazioni del pouf e della panca imbottita.

The Jane collection is inspired by the idea of elegant environments where you can create spaces dedicated to comfort and intimacy. The homonymous armchair of small dimensions, soft and compact, expresses a contemporary and timeless style. The same harmonious proportions can be found in the most generous volumes of the love seat, of Jane Large, and of Jane Lounge, and in the variations of the pouf and the upholstered bench.





Nella pagina precedente: poltrona Jane con rivestimento sfoderabile in velluto Persia 54 prussia, basamento in olmo nero. Tappeto Frame carbone. In questa pagina: divani Jane con rivestimento sfoderabile in tessuto Orleans 12 carbone, basamento in olmo nero. Poltrone Jane con rivestimento non sfoderabile in pelle Soft 10 prugna, basamento in olmo nero. Tavolino Henry in olmo nero con piano in vetro lucido bordeaux. Tavolino Soori in metallo con finitura bronzo anticato. Tappeto Frame perla. Sullo sfondo: composizione Quid con bacheche a giorno in olmo nero. Tavolino Dama laccato lucido canapa.

Previous page: Jane armchair with removable cover in velvet Persia 54 prussia, base in black elm. Carpet Frame carbone. This page: Jane sofas with removable cover in fabric Orleans 12 carbone, base in black elm. Jane armchairs with non-removable cover in leather Soft 10 prugna and base in black elm. Henry coffee table in black elm with top in glossy glass bordeaux. Soori coffee table in metal with antique bronze finish. Carpet Frame perla. In the background: Quid composition with open display cases in black elm. Canapa glossy lacquered Dama coffee table.



In questa pagina: poltrona Jane con rivestimento non sfoderabile in pelle Soft 10 prugna, basamento in brown nickel lucido. Nella pagina successiva: divano Jane con rivestimento non sfoderabile in pelle Nabuk 01 latte, basamento in brown nickel lucido.

This page: Jane armchair with non-removable cover in leather Soft 10 prugna, glossy brown nickel base. Next page: Jane sofa with non-removable cover in leather Nabuk 01 latte, glossy brown nickel base.







In questa pagina: poltrona Jane con rivestimento sfoderabile in tessuto Orleans 12 carbone, basamento in rovere spessart.

This page: Jane armchair with removable cover in fabric Orleans 12 carbone, base in spessart oak.







Nella pagina precedente: poltrone Jane Large con rivestimento sfoderabile in tessuto Kitami 04 sabbia, basamento in olmo nero. Tavolino Dama in legno massello noce. Day bed Bellport in pelle sfoderabile Nabuk 08 prussia e piedini con profilo in brown nickel opaco. Tavolini Soori in metallo con finitura bronzo anticato. Composizione Quid con bacheche a giorno, struttura e schienali in olmo nero, ripiani in olmo nero e vetro trasparente extrachiario con luce a led integrata, boiserie centrale in laccato metallico ottone. In questa pagina: poltrona Jane Large e pouf Jane con rivestimento sfoderabile in tessuto Sendai 03 fango, basamento in olmo nero. Poltrona con bordura gros-grain nero.

Previous page: Jane Large armchairs with removable cover in fabric Kitami 04 sabbia, black elm base. Dama coffee table in solid wood walnut. Bellport day bed in removable leather Nabuk 03 prussia and feet with profile in mat brown nickel. Soori coffee tables in metal with antique bronze finish. Quid composition with open display cases, structure and backs in black elm, shelves in black elm and extra light transparent glass with integrated led light, metal lacquered ottone central wall panelling. This page: Jane Large armchair and Jane pouf with removable cover in fabric Sendai 03 fango, black elm base. Armchair with border in grosgrain nero.





In questa pagina: poltrona Jane Large con rivestimento non sfoderabile, esterno in pelle Soft 08 visone, interno in tessuto Nayoro 02 sabbia, basamento in olmo nero.

This page: Jane Large armchair with non-removable cover, outer cover in leather Soft 08 visone, inner cover in fabric Nayoro 02 sabbia, base in black elm.



In questa pagina: poltrona Jane Lounge con rivestimento non sfoderabile in pelle Soft 14 oliva, basamento in olmo nero. Composizione Quid con contenitori a terra con top e ante scorrevoli complanari in olmo nero, profili maniglia in brown nickel opaco. Mensole a muro Wall System in laccato opaco canapa.

This page: Jane Lounge armchair with non-removable cover in leather Soft 14 oliva, base in black elm. Quid composition with floorstanding storage units with top and coplanar doors in black elm with mat brown nickel handle profiles. Wall System wall mounted shelves in mat lacquer canapa.



In questa pagina: poltrona Jane Lounge con poggiatesta, rivestimento non sfoderabile, esterno in pelle Nabuk 02 tortora, interno in tessuto Lero 01 écru, basamento in noce gold. Sotto: dettaglio del poggiatesta in tessuto sfoderabile Lero 01 écru, peso in metallo brunito.

This page: Jane Large armchair with headrest, non-removable cover, outer cover in leather Nabuk 02 tortora, inner cover in fabric Lero 01 écru, base in gold walnut. Below: close up of the headrest in removable fabric Lero 01 écru, weight in burnished metal.





In questa pagina: poltrona Jane Lounge e Jane pouf con rivestimento non sfoderabile in pelle Nabuk 09 ruggine, basamento in olmo nero.

This page: Jane Lounge armchair and Jane pouf with non-removable cover in leather Nabuk 09 ruggine, base in black elm.



In questa pagina: poltrona Jane Large e pouf Jane con rivestimento non sfoderabile in pelle Nabuk 09 ruggine, basamento in olmo nero. Tavolino Soori finitura bronzo anticato. Composizione Quid con bacheche a giorno, struttura in olmo nero e schienali in laccato lucido corda, ripiani in olmo nero e vetro trasparente extrachiaro.

This page: Jane Large armchair and Jane pouf with non-removable cover in leather Nabuk 09 ruggine, black elm base. Soori coffee table with antique bronze finish. Quid composition with open display cases, structure in black elm and backs in glossy lacquer corda, shelves in black elm and extra light transparent glass.



## JANE COLLECTION

Design Emmanuel Gallina

### Jane, 2017

Scocca e seduta in poliuretano flessibile stampato con parti in poliuretano flessibile a quote differenziate. Prerivestimento parti in tela cotone con piuma e parti in ovatta di poliestere accoppiata. Rivestimento in tessuto sfoderabile o in pelle non sfoderabile. Basamento e gambe in massello, finitura noce gold, rovere spessart o olmo nero. Basamento e gambe in metallo verniciato brown nickel opaco o lucido. Cuscino salvareni opzionale, rivestimento sfoderabile in tessuto o pelle.

Body and seat in flexible moulded polyurethane with parts in multi-density flexible polyurethane. Pre-cover with parts in cotton cloth and parts in polyester wadding. Cover in removable fabric or in non-removable leather. Base and legs in solid wood, finish gold walnut, spessart oak or black elm. Base and legs in mat or glossy brown nickel painted metal. Optional lower back cushion with removable cover in fabric or leather.

#### basamento essenza wooden base

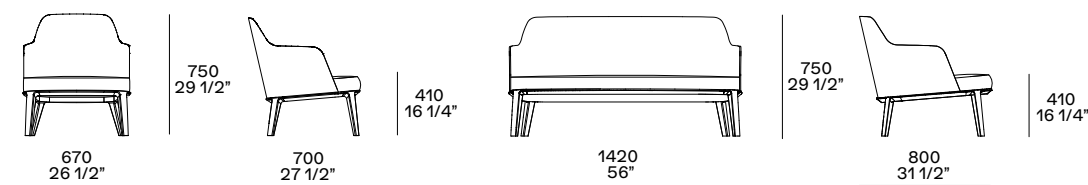

#### basamento metallo metal base

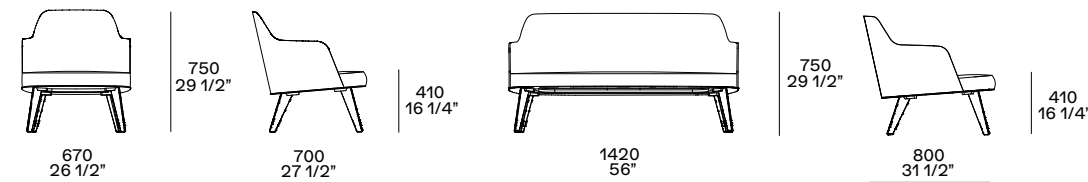

### Jane Pouf, 2018

Seduta in poliuretano flessibile a quote differenziate, prerivestimento in fibra di poliestere. Rivestimento in tessuto sfoderabile o in pelle non sfoderabile. Basamento e gambe in massello, finitura noce gold, rovere spessart o olmo nero.

Seat in multi-density flexible polyurethane, pre-cover in polyester fibre. Cover in removable fabric or in non-removable leather. Base and legs in solid wood finish gold walnut, spessart oak or black elm.

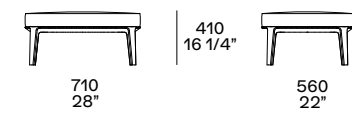

### Jane Large, 2018

Scocca e seduta in poliuretano flessibile stampato con parti in poliuretano flessibile a quote differenziate. Prerivestimento in fibra di poliestere, piuma e tela cotone. Rivestimento in tessuto sfoderabile o in pelle non sfoderabile. Bordura gros-grain nei colori da campionario. Possibilità di rivestimento diverso tra interno ed esterno della scocca, rivestimento non sfoderabile se il tessuto viene abbinato a una pelle. Basamento e gambe in massello, finitura noce gold, rovere spessart o olmo nero.

Body and seat in flexible moulded polyurethane with parts in multi-density flexible polyurethane. Pre-cover in polyester fibre, down and cotton canvas. Cover in removable fabric or in non-removable leather. Grosgrain border in the sample colours. The inner and outer cover of the body can be in two different materials, the cover is removable but not washable in case of combination of fabric and leather. Base and legs in solid wood finish gold walnut, spessart oak or black elm.

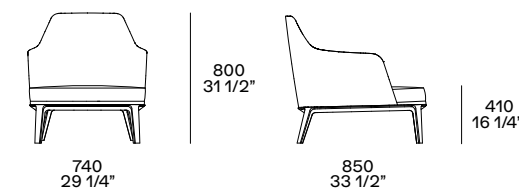

### Jane Lounge, 2018

Scocca e seduta in poliuretano flessibile stampato con parti in poliuretano flessibile a quote differenziate. Prerivestimento in fibra di poliestere, piuma e tela cotone. Rivestimento in tessuto sfoderabile o in pelle non sfoderabile. Bordura gros-grain nei colori da campionario. Possibilità di rivestimento diverso tra interno ed esterno della scocca, rivestimento non sfoderabile se il tessuto viene abbinato a una pelle. Basamento e gambe in massello, finitura noce gold, rovere spessart o olmo nero. Poggiatesta opzionale in piuma, peso in metallo brunito, rivestimento sfoderabile in tessuto o pelle.

Body and seat in flexible moulded polyurethane with parts in multi-density flexible polyurethane. Pre-cover in polyester fibre, down and cotton canvas. Cover in removable fabric or in non-removable leather. Grosgrain border in the sample colours. The inner and outer cover of the body can be in two different materials, the cover is removable but not washable in case of combination of fabric and leather. Base and legs in solid wood finish gold walnut, spessart oak or black elm. Optional headrest in down, weight in burnished metal, removable cover in fabric or leather.

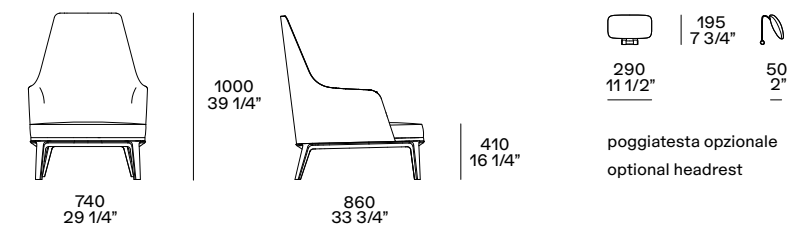



# SANTA MONICA COLLECTION

La poltrona Santa Monica ha forme avvolgenti e confortevoli, dettagli sartoriali e diversi rivestimenti disponibili, in pelle o tessuto. La sua raffinatezza si sostanzia anche nella versione Lounge, con schienale alto e pouf coordinato, e nella Santa Monica Home, con poggiatesta.

The Santa Monica armchair has enveloping and comfortable shapes, tailored details, and several coverings available, in leather or fabric. Its refinement is also confirmed in the Lounge version, with high back and coordinated pouf, and in the Santa Monica Home, with headrest.



Nella pagina precedente: poltrone Santa Monica con rivestimento sfoderabile in pelle Nabuk 02 tortora e cucitura normale doppia. Tavolino Soori in metallo finitura bronzo anticato. In questa pagina: poltrona Santa Monica con rivestimento sfoderabile in pelle Nabuk 02 tortora e cucitura normale doppia.

Previous page: Santa Monica armchairs with removable cover in leather Nabuk 02 tortora and normal double stitching. Soori coffee table in metal with antique bronze finish. This page: Santa Monica armchair with removable cover in leather Nabuk 02 tortora and normal double stitching.





In questa pagina: poltrona Santa Monica con rivestimento sfoderabile versione fondopiega in tessuto Olimpia 11 polvere, cuciture a cordoncino e bordure gros-grain nero.

This page: Santa Monica armchair with removable slipcover in fabric Olimpia 11 polvere, drawstring stitching and border in grosgrain nero.



In questa pagina: poltrona Santa Monica Lounge e pouf Santa Monica con rivestimento sfoderabile in tessuto Naxos 17 corda e cuciture a cordoncino nero.

This page: armchair Santa Monica Lounge and pouf Santa Monica with removable cover in fabric Naxos 17 corda and drawstring stitching nero.



SANTA MONICA LOUNGE



ARMCHAIRS

In questa pagina: poltrona Santa Monica Lounge e pouf Santa Monica con rivestimento sfoderabile versione fondopiega in tessuto Lima 43 écreu, cuciture a cordoncino e bordure gros-grain sahara.

This page: armchair Santa Monica Lounge and pouf Santa Monica with removable cover in the version with slipcover in fabric Lima 43 ecru, drawstring stitching and border in grosgrain sahara.





In questa pagina: poltrona Santa Monica Lounge con rivestimento sfoderabile in tessuto Sparta 16 ferro e cucitura normale doppia. Sotto: dettaglio degli alamari che caratterizzano la collezione Santa Monica con il rivestimento in tessuto sia nella versione tesata che con fondopiega.

This page: Santa Monica Lounge armchair with removable cover in fabric Sparta 16 ferro and normal double stitching. Below: close up of the fasteners distinguishing Santa Monica collection, both with stretched cover and with slipcover.

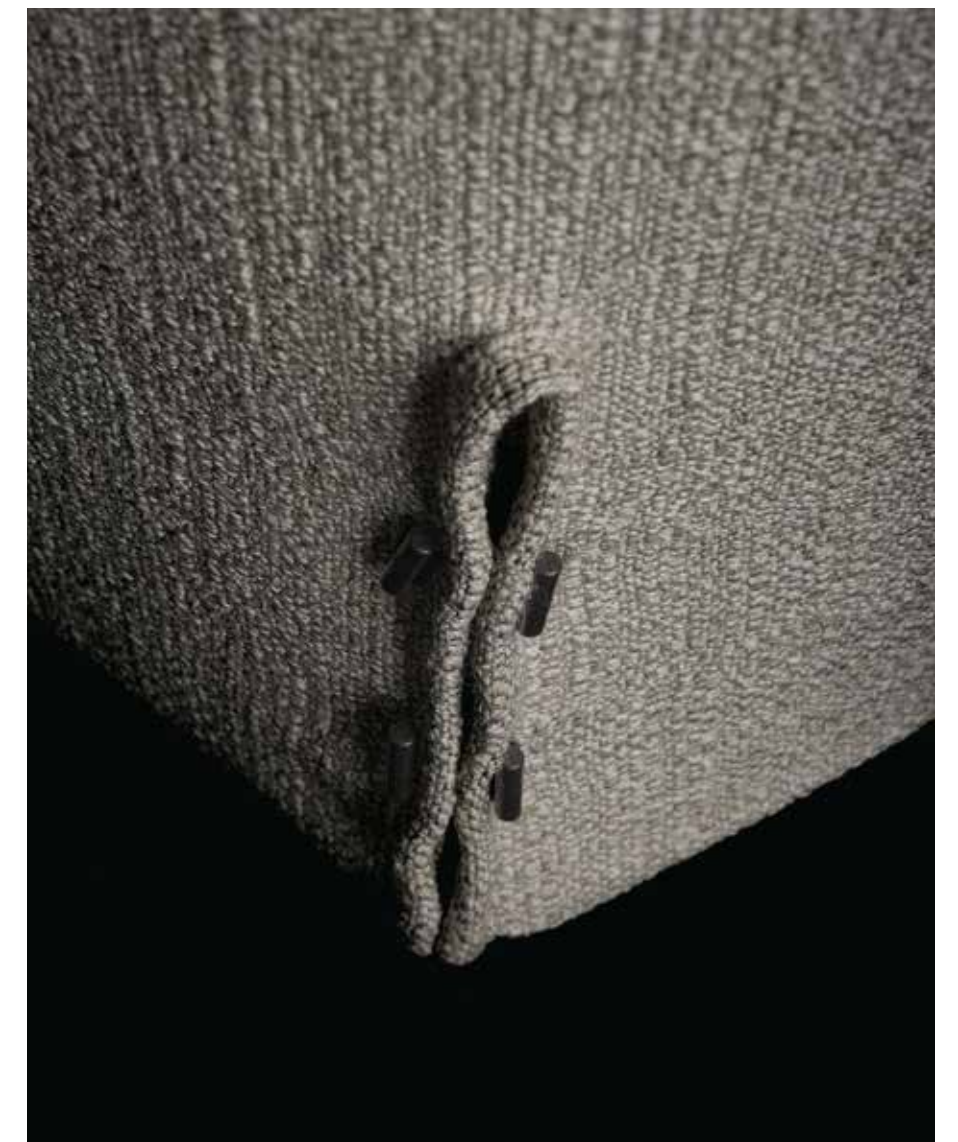

In questa pagina: poltrona Santa Monica Home con rivestimento sfoderabile in tessuto Naxos 27 prussia e cucitura normale doppia. Tavolino Tribeca in brown nickel opaco con piano in marmo emperador dark lucido. Composizione Wall System con struttura in rovere spessart, vetrine sporgenti Ghost con ante in vetro trasparente riflettente, profilo verniciato opaco ardesia e schienali in laccato opaco caramello, luce a led integrata.

This page: Santa Monica Home armchair with removable cover in fabric Naxos 27 prussia and normal double stitching. Tribeca coffee table in mat brown nickel with top in glossy marble emperador dark. Wall System composition with structure in spessart oak, jutting Ghost showcases with doors in transparent reflecting glass, mat ardesia painted profile and backs in mat lacquer caramello, integrated led light.





In questa pagina: poltrona Santa Monica Home con rivestimento sfo-  
derabile in tessuto Caleo 02 sabbia e cucitura normale doppia.

This page: Santa Monica Home armchair with removable cover in fa-  
bric Caleo 02 sabbia and normal double stitching.





In questa pagina: poltrona Santa Monica Home con rivestimento sfoderabile in tessuto Sparta 24 oceano e cucitura normale doppia.

This page: Santa Monica Home armchair with removable cover in fabric Sparta 24 oceano and normal double stitching.



## SANTA MONICA COLLECTION

Design Jean-Marie Massaud

### Santa Monica, 2011

Scocca e seduta in poliuretano flessibile stampato in doppia densità. Prerivestimento parti in tela cotone con interno in piuma e parti in fibra di poliestere accoppiata. Piedini in materiale plastico o base girevole. Rivestimento versione tesato sfoderabile in tessuto o pelle. Rivestimento versione fondopiega sfoderabile in tessuto. Versione in tessuto tesato o fondopiega con alamari. Cucitura normale doppia o a cordoncino con filato nei diversi colori da campionario (escluso rivestimento in pelle e velluto). Bordure gros-grain nei colori da campionario, solo per rivestimento versione fondopiega.

Body and seat in flexible moulded polyurethane with double density. Pre-cover: parts in cotton canvas with down inside and parts in coupled polyester fibre. Feet in plastic material or swivel base. Version with stretched cover removable in fabric and leather. Version with slipcover removable in fabric. Version with stretched fabric or slipcover with fasteners. Normal double stitching or drawstring stitching with yarn in the colours as per sample book (except for cover in leather and in velvet). Grosgrain border in the colours as per sample book, only for the version with slipcover.

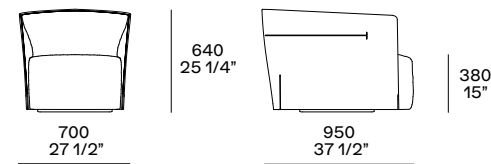

rivestimento tesato  
stretched cover

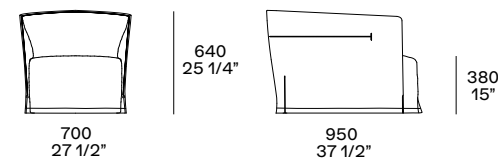

rivestimento fondopiega  
slipcover

### Santa Monica Home, 2015

Scocca e seduta in poliuretano flessibile stampato in doppia densità. Prerivestimento parti in tela cotone con interno in piuma e parti in fibra di poliestere accoppiata. Piedini in materiale plastico o base girevole. Rivestimento in tessuto sfoderabile o in pelle non sfoderabile. Cucitura normale doppia.

Body and seat in flexible moulded polyurethane with double density. Pre-cover with parts in cotton canvas with down inside and parts in coupled polyester fibre. Feet in plastic material or swivel base. Cover in removable fabric or in non-removable leather. Normal double stitching.

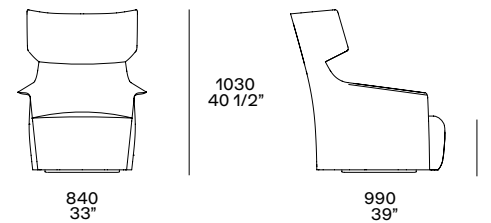

### Santa Monica Lounge, 2012

Scocca e seduta in poliuretano flessibile stampato in doppia densità. Prerivestimento parti in tela cotone con interno in piuma e parti in fibra di poliestere accoppiata. Piedini in materiale plastico o base girevole. Rivestimento versione tesato sfoderabile in tessuto o pelle. Rivestimento versione fondopiega sfoderabile in tessuto. Versione in tessuto tesato o fondopiega con alamari. Cucitura normale doppia o a cordoncino con filato nei diversi colori da campionario (escluso rivestimento in pelle e velluto). Bordure gros-grain nei colori da campionario, solo per rivestimento versione fondopiega.

Body and seat in flexible moulded polyurethane with double density. Pre-cover: parts in cotton canvas with down inside and parts in coupled polyester fibre. Feet in plastic material or swivel base. Version with stretched cover removable in fabric and leather. Version with slipcover removable in fabric. Version with stretched fabric or slipcover with fasteners. Normal double stitching or drawstring stitching with yarn in the colours as per sample book (except for cover in leather and in velvet). Grosgrain border in the colours as per sample book, only for the version with slipcover.

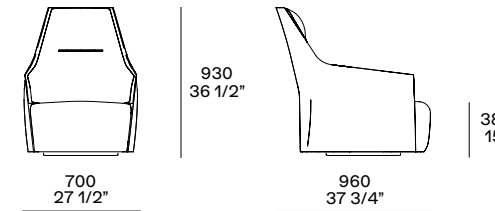

rivestimento tesato  
stretched cover

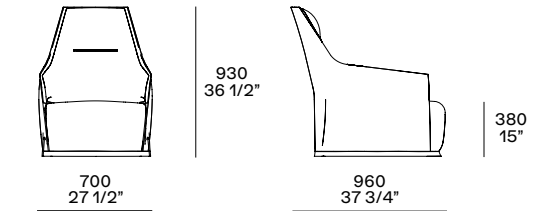

rivestimento fondopiega  
slipcover

### Santa Monica Pouf, 2012

Seduta in poliuretano flessibile stampato in doppia densità. Prerivestimento parti in tela cotone con interno in piuma e parti in fibra di poliestere accoppiata. Piedini in materiale plastico. Rivestimento versione tesato sfoderabile in tessuto o pelle. Rivestimento versione fondopiega sfoderabile in tessuto. Cucitura normale doppia o a cordoncino con filato nei diversi colori da campionario (escluso rivestimento in pelle e velluto). Bordure gros-grain nei colori da campionario, solo per rivestimento versione fondopiega.

Seat in flexible moulded polyurethane with double density. Pre-cover: parts in cotton canvas with down inside and parts in coupled polyester fibre. Feet in plastic material. Version with stretched cover removable in fabric and leather. Version with slipcover removable in fabric. Normal double stitching or drawstring stitching with yarn in the colours as per sample book (except for cover in leather and in velvet). Grosgrain border in the colours as per sample book, only for the version with slipcover.

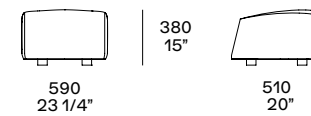

rivestimento tesato  
stretched cover

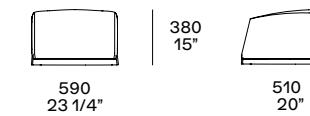

rivestimento fondopiega  
slipcover



# IPANEMA

Con Ipanema Jean-Marie Massaud disegna per Poliform una poltrona raffinata che interpreta un comfort da vivere in libertà. Il design della struttura, controllato e minimale, si combina con l'attenzione per la comodità, con cuscini in appoggio o struttura rivestita in tessuto o pelle. Una poltrona ergonomica e versatile, disponibile anche nella versione sedia.

With Ipanema, Jean-Marie Massaud designs a refined armchair for Poliform that interprets a comfort to be experienced in freedom. The design of the structure, controlled and minimalistic, combines with the attention to comfort, with removable cushions or structure covered in fabric or leather. An ergonomic and versatile armchair, also available in the chair version.





Nella pagina precedente: poltrone Ipanema in olmo nero e seduta con rivestimento non sfoderabile in pelle Nabuk 01 latte. Tavolino Home Hotel in olmo nero. In questa pagina: poltrone Ipanema in rovere spessart, seduta con cinghie in cuoio 03 grigio scuro e cuscino seduta opzionale con rivestimento sfoderabile in velluto Persia 1401 oliva.

Previous page: Ipanema armchairs in black elm and seat with non-removable cover in leather Nabuk 01 latte. Home Hotel coffee table in black elm. This page: Ipanema armchairs in spessart oak, seat with belts in hide 03 grigio scuro and optional seat cushion with removable cover in velvet Persia 1401 oliva.



In questa pagina: poltrona Ipanema in olmo nero e seduta con rivestimento non sfoderabile in pelle Soft 02 mastice. Nella pagina successiva: poltrona Ipanema in rovere spessart, seduta con cinghie in cuoio 15 prugna e cuscino seduta opzionale con rivestimento sfoderabile in tessuto Sheffield 08 corallo.

This page: Ipanema armchair in black elm and seat with non-removable leather Soft 02 mastice. Next page: Ipanema armchair in spessart oak, seat with belts in hide 15 prugna and optional seat cushion with removable cover in fabric Sheffield 08 corallo.





## IPANEMA

Design Jean-Marie Massaud, 2013

Struttura in massello, finitura in rovere spessart o olmo nero.

Seduta con cinghie in cuoio o imbottita.

Versione con cinghie in cuoio colori, cuscino seduta opzionale con imbottitura in piuma, prerivestimento in tela cotone e rivestimento sfoderabile in tessuto o pelle. Versione imbottita con seduta in poliuretano flessibile stampato, prerivestimento in fibra di poliestere e rivestimento non sfoderabile in tessuto o pelle.

Structure in solid wood finish spessart oak or black elm.

Seat with hide belts or upholstered.

Version with hide belts in the sample colours, optional seat cushion with down padding, pre-cover in cotton canvas and removable cover in fabric or leather. Padded version with seat in flexible moulded polyurethane, pre-cover in polyester fibre and non-removable cover in fabric or leather.

### Seduta con cinghie in cuoio Seat with hide belts

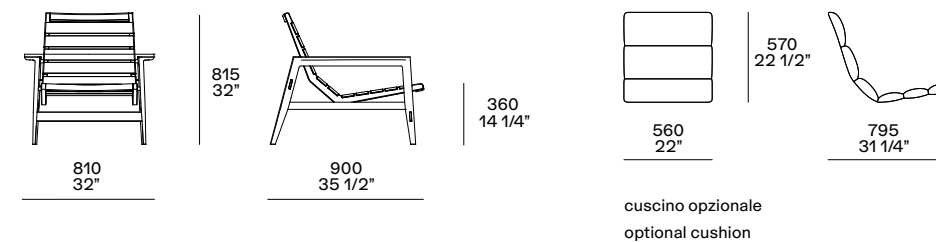

### Seduta imbottita Seat upholstered

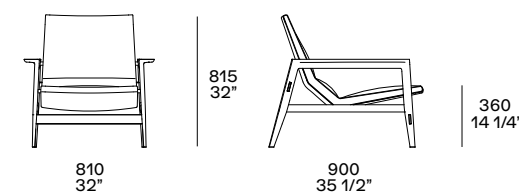





# GASTON

Lineare, essenziale, invitante. La poltroncina Gaston, disegnata da Vincent Van Duysen, evoca uno stile esclusivo e lo conferma nei dettagli come gli spessori minimali della struttura in metallo, le cuciture e il rivestimento del bracciolo, sottile e confortevole. Disponibile con rivestimento in pelle o tessuto, Gaston arreda con raffinatezza gli ambienti giorno e notte.

Linear, minimalistic, inviting. The Gaston armchair, designed by Vincent Van Duysen, evokes an exclusive style and confirms it in the details like the minimal thicknesses of the metal structure, the stitching, and the covering of the armrest, thin and comfortable. Available in leather or fabric, Gaston furnishes the day and night environments with refinement.



Nella pagina precedente: poltrona Gaston con rivestimento non sfoderabile in pelle Soft 13 carbone, struttura verniciata lucido carbone e bracciolo rivestito con la stessa pelle della seduta. In questa pagina: poltrona Gaston con rivestimento sfoderabile in tessuto Kitami 11 oceano, struttura verniciata brown nickel opaco. Sotto: dettaglio del bracciolo rivestito in pelle, in tinta alla struttura. Nella pagina successiva: poltrona Gaston con rivestimento non sfoderabile in pelle Nabuk 07 camoscio, struttura verniciata lucido bianco e bracciolo rivestito con la stessa pelle della seduta.

Previous page: Gaston armchair with non-removable cover in leather Soft 13 carbone, carbone glossy lacquered structure and armrest covered in the same leather of the seat. This page: Gaston armchair with removable cover in fabric Kitami 11 oceano, mat brown nickel painted structure. Below: close up of the armrest covered in leather in matching colour with the structure. Next page: Gaston armchair with non-removable cover in leather Nabuk 07 camoscio, bianco glossy lacquered structure and armrest covered in the same leather of the seat.

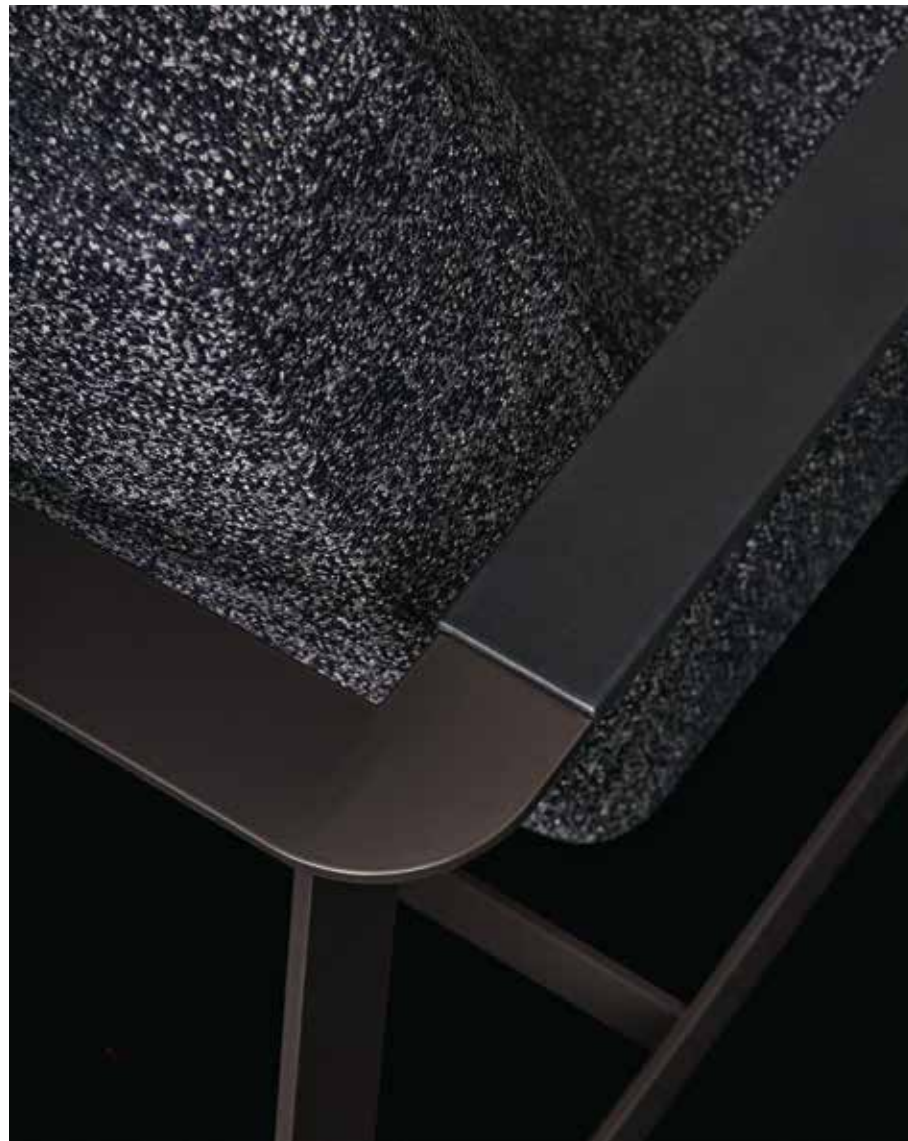



## GASTON

Design Vincent Van Duysen, 2008

Scocca in poliuretano stampato con inserti di poliuretano espanso a quote differenziate e piuma, prerivestimento in tela cotone e fibra di poliestere. Rivestimento in tessuto sfoderabile o in pelle non sfoderabile. Struttura in metallo verniciato brown nickel opaco e lucido o lucido bianco e carbone. Braccioli rivestiti in pelle o come il rivestimento della seduta o in tinta alla struttura se il rivestimento della seduta è in tessuto.

Body in moulded polyurethane with inlays in multi-density polyurethane foam and down, pre-cover in cotton canvas and polyester fibre. Cover in removable fabric or in non-removable leather. Structure in painted metal mat and glossy brown nickel or glossy bianco and carbone. Armrests covered in leather or in the same material of the seat cushion; if the seat cushion is in fabric, the armrests are leather covered in the same colour of the structure.

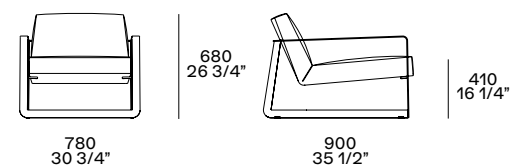

# MARLON COLLECTION

La forte personalità di Marlon deriva dall'accostamento fra il basamento in legno e la scocca della seduta plastica ed ergonomica, disponibile con schienali di due altezze diverse. Un progetto di Vincent Van Duysen che parla un linguaggio moderno e sofisticato, con rivestimento in pelle o in tessuto.

The strong personality of Marlon comes from the combination of the wooden base with the plastic and ergonomic body of the seat, available with backs of two different heights. A project by Vincent Van Duysen that speaks a modern and sophisticated language, in leather or fabric.





Nella pagina introduttiva: poltrona Marlon Lounge con rivestimento sfoderabile in tessuto Sparta 16 ferro, basamento in olmo nero. Nella pagina precedente: poltrone Marlon con rivestimento sfoderabile in pelle Soft 14 oliva, basamento in olmo nero. Tavolino Mondrian piano in marmo opaco calacatta oro e struttura in fusione di bronzo lucidata oro. In questa pagina: poltrona Marlon con rivestimento sfoderabile in tessuto Nayoro 02 sabbia, basamento in rovere spessart.

Introduction page: Marlon Lounge armchair with removable cover in fabric Sparta 16 ferro, base in black elm. Previous page: Marlon armchairs with removable cover in leather Soft 14 oliva, base in black elm. Mondrian coffee table with top in mat marble calacatta oro and structure in gold polished bronze casting. This page: Marlon armchair with removable cover in fabric Nayoro 02 sabbia, base in spessart oak.







In questa pagina: poltrona Marlon Lounge con rivestimento sfoderabile in velluto Persia 1404 carbone, basamento in olmo nero. Nella pagina successiva: poltrone Marlon con rivestimento sfoderabile in tessuto Sparta 16 ferro, basamento in olmo nero. Tavolino Mondrian piano in marmo opaco calacatta oro e struttura in fusione di bronzo lucidata oro.

This page: Marlon Lounge armchair with removable cover in velvet Persia 1404 carbone, base in black elm. Next page: Marlon armchairs with removable cover in fabric Sparta 16 ferro, base in black elm. Mondrian coffee table with top in mat marble calacatta oro and structure in gold polished bronze casting.

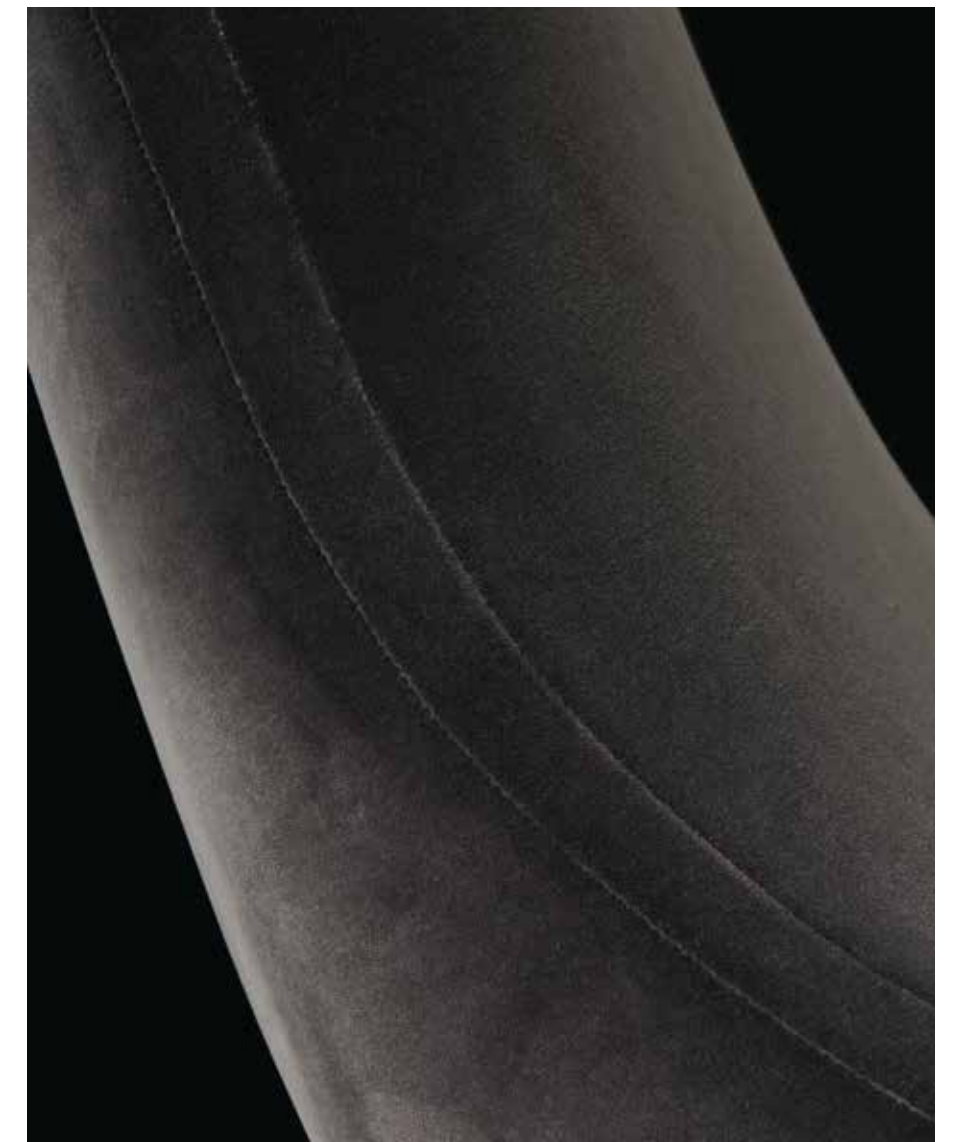



## MARLON COLLECTION

Design Vincent Van Duysen, 2016

### Marlon

Scocca e seduta in poliuretano flessibile stampato con parti in poliuretano flessibile a quote differenziate, prerivestimento in fibra di poliestere. Rivestimento sfoderabile in tessuto o pelle. Basamento in massello, finitura in rovere spessart o olmo nero.

Body and seat in flexible moulded polyurethane with parts in multi-density flexible polyurethane, pre-cover in polyester fibre. Removable cover in fabric or leather. Base in solid wood finish spessart oak or black elm.

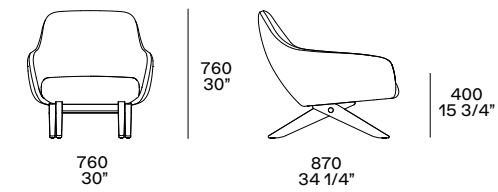

### Marlon Lounge

Scocca e seduta in poliuretano flessibile stampato con parti in poliuretano flessibile a quote differenziate, prerivestimento in fibra di poliestere. Rivestimento sfoderabile in tessuto o pelle. Basamento in massello, finitura in rovere spessart o olmo nero.

Body and seat in flexible moulded polyurethane with parts in multi-density flexible polyurethane, pre-cover in polyester fibre. Removable cover in fabric or leather. Base in solid wood finish spessart oak or black elm.

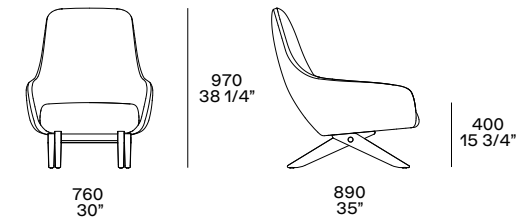



# VENTURA LOUNGE

Evoluzione della sedia Ventura, di cui riprende la giunzione fra il basamento e lo schienale della seduta, Ventura Lounge è una poltrona dal grande comfort e massima raffinatezza. Per favorire il rilassamento, lo schienale è allungato e inclinato in modo ergonomico. In alcune versioni in tessuto è possibile far diventare protagoniste le cuciture, con profili a cordoncino in contrasto colore.

Evolution of the Ventura chair, from which it takes the connection between the base and the back of the seat, Ventura Lounge is an armchair of great comfort and maximum refinement. To promote relaxation, the backrest is elongated and inclined ergonomically. In some fabric versions you can put the spotlight on the seams, with corded profiles in contrasting colour.

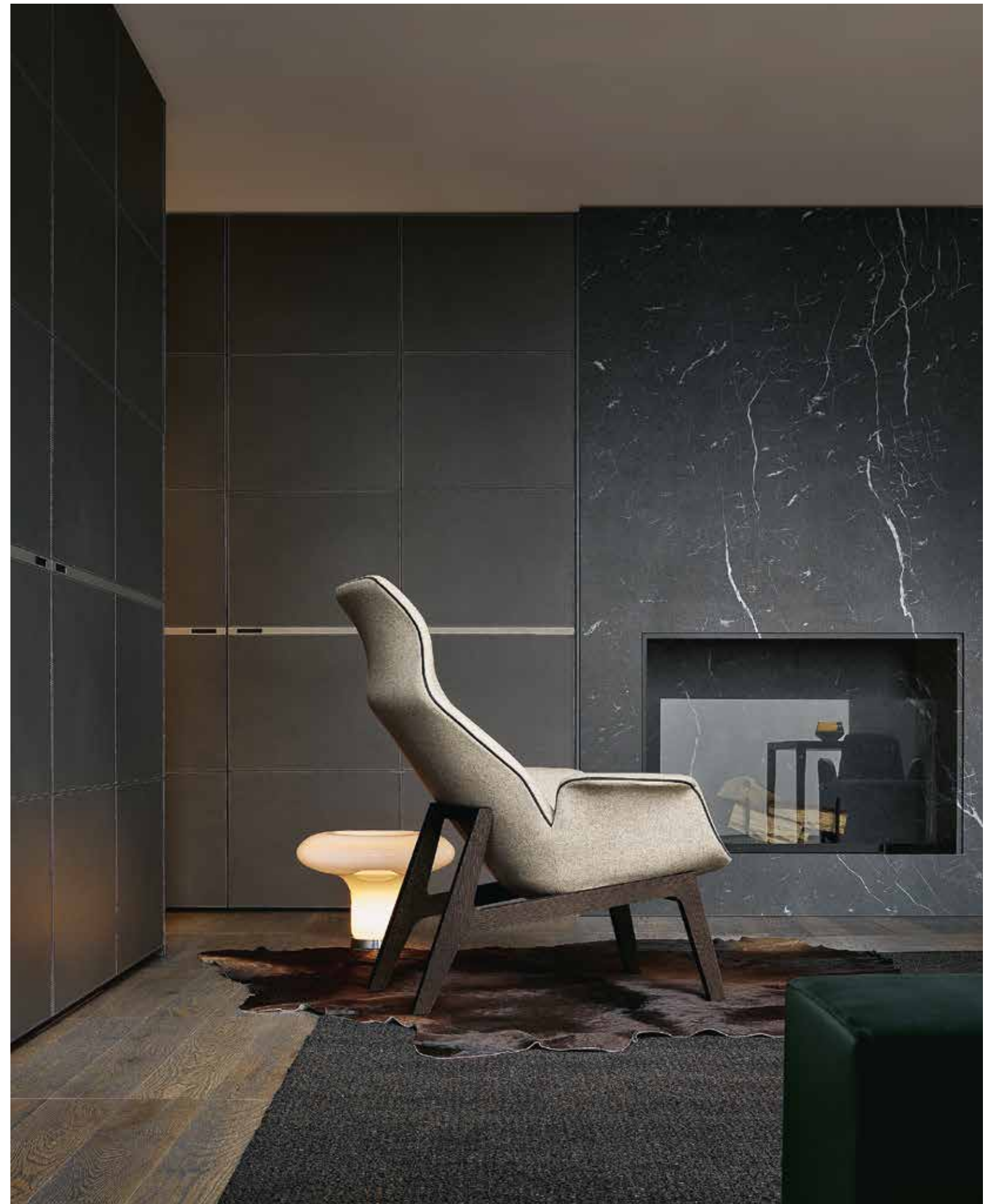

Qui e nella pagina precedente: poltrona Ventura Lounge con rivestimento sfoderabile in tessuto Agadir 01 sabbia e cuciture a cordoncino nero, struttura in rovere spessart. Armadi Senzafine Bangkok, apertura complanare, ante rivestite in cuoio 03 grigio scuro con profili maniglia ardesia opaco. Sedia Guest in velluto non sfoderabile Persia 2012 visone. Pouf Onda in pelle non sfoderabile Nabuk 02 tortora.

This and previous page: Ventura Lounge armchair with removable cover in fabric Agadir 01 sabbia and drawstring stitching nero, structure in spessart oak. Wardrobes Senzafine Bangkok, coplanar doors covered in hide 03 grigio scuro with handle profiles mat ardesia. Guest chair in non-removable velvet Persia 2012 visone. Onda pouf in non-removable leather Nabuk 02 tortora.



In questa pagina: poltrona e pouf Ventura Lounge con rivestimento sfoderabile in tessuto Antea 14 foresta e cuciture a cordoncino acciaio, struttura in rovere spessart. Nella pagina successiva: poltrona Ventura Lounge con rivestimento sfoderabile in pelle Nabuk 02 tortora e cucitura normale doppia, struttura in olmo nero.

This page: Ventura Lounge armchair and pouf with removable cover in fabric Antea 14 foresta and drawstring stitching acciaio, structure in spessart oak. Next page: Ventura Lounge armchair with removable cover in leather Nabuk 02 tortora and normal double stitching, structure in black elm.





## VENTURA LOUNGE

Design Jean-Marie Massaud, 2013

Scocca e seduta in poliuretano flessibile stampato, prerivestimento in fibra di poliestere. Rivestimento sfoderabile in tessuto o pelle. Cucitura normale doppia o a cordoncino con filato nei diversi colori da campionario (escluso rivestimento in pelle e velluto). Struttura in massello, finitura in rovere spessart o olmo nero.

Body and seat in flexible moulded polyurethane, pre-cover in polyester fibre. Removable cover in fabric and leather. Normal double stitching or drawstring stitching with yarn in the colours as per sample book (except for cover in leather and in velvet). Structure in solid wood finish spessart oak or black elm.

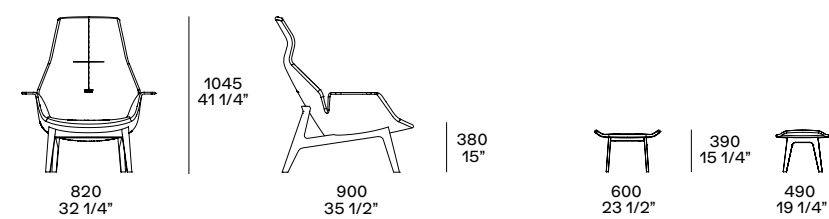

# WALLACE



Jean-Marie Massaud firma una proposta dal design fortemente innovativo. Wallace è una poltrona di grande effetto, con un basamento in metallo dalle geometrie irregolari che sorregge la struttura in poliuretano rivestito in pelle. La seduta attira lo sguardo con la sua forma particolare, avvolgendo in un comfort unico chi vi si adagia.

Jean-Marie Massaud signs an item with a highly innovative design. Wallace is an armchair of great impact, with a metal base with irregular geometric shapes that supports the polyurethane structure covered in leather. The seat catches the eye with its particular shape, enveloping in a unique comfort who lies on it.

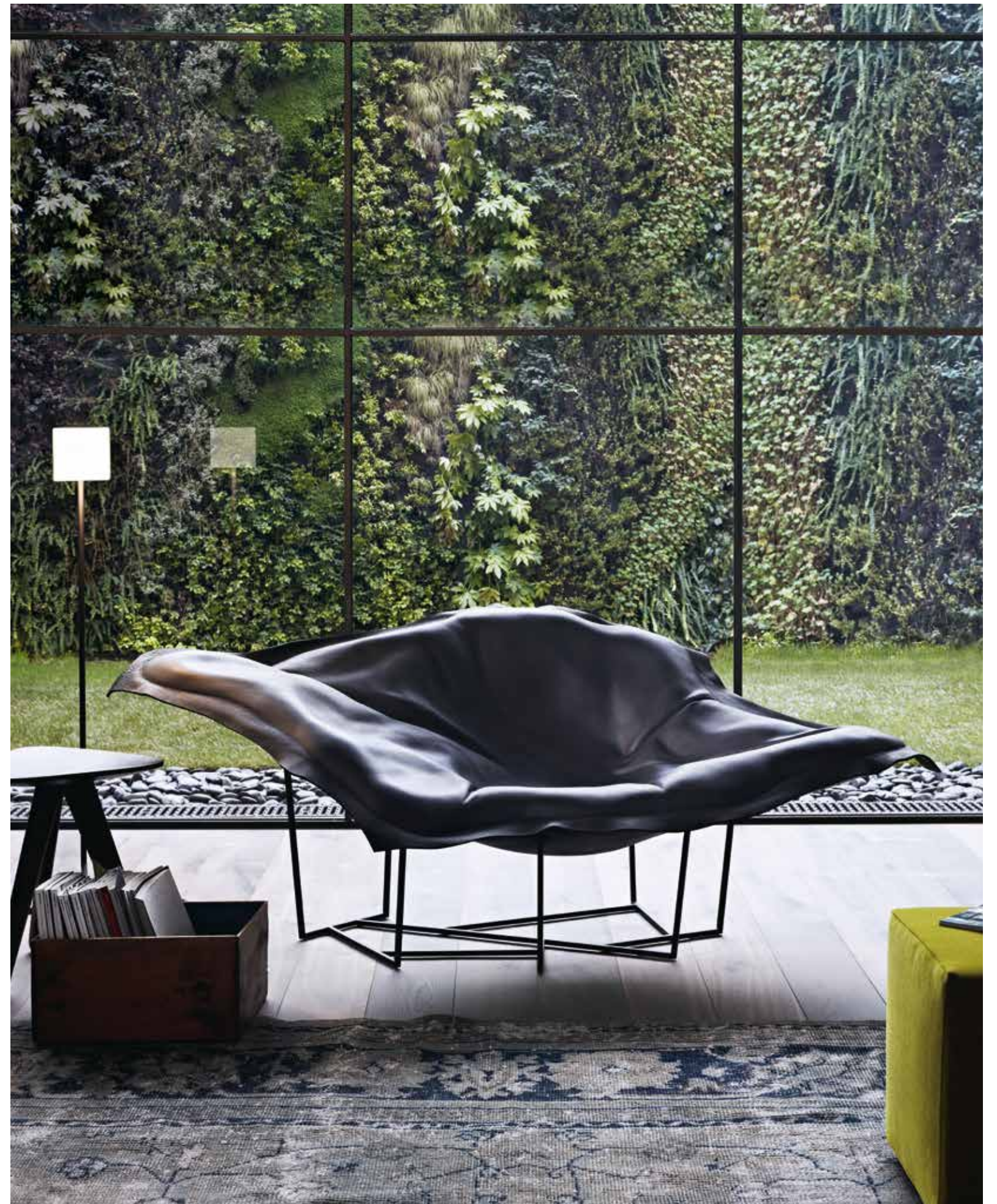





## WALLACE

Design Jean-Marie Massaud, 2010

Scocca in poliuretano flessibile stampato.  
Rivestimento non sfoderabile in pelle.  
Struttura in metallo verniciato brown nickel  
opaco e lucido, verniciato bianco o carbone  
opaco.

Body in flexible moulded polyurethane.  
Cover in non-removable leather. Structure  
in painted metal mat and glossy brown  
nickel, painted mat bianco or carbone.

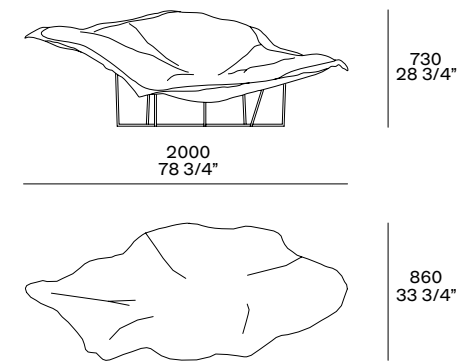

Qui e nelle pagine precedenti: poltrona Wallace con rivestimen-  
to non sfoderabile in pelle Special 14 nero e struttura in brown  
nickel opaco.

This and previous pages: Wallace armchair with non-removable  
cover in leather Special 14 nero and mat brown nickel structure.

TECHNICAL DATA

TAPPETI  
CARPETS

500

FINITURE  
FINISHINGS

506

INDICE PRODOTTI  
PRODUCT INDEX

514

## TAPPETI CARPETS

### Relief

Prodotto a mano con tecnica handloom.  
Trama in cotone, vello in lana himalayana  
e seta di bambù, bouclé in lana himalayana.  
Dimensioni mm: rettangolare 1700×2400  
2300×3000 - 3000×4000  
quadrato 3000×3000.

Handmade with the handloom technique.  
Cotton weave, fleece in Hymalayan wool  
and bamboo silk, Hymalayan wool bouclé.  
Dimensions in: rectangular 67"x94 1/2"  
90 1/2"x118" - 118"x157 1/2"  
square 118"x118".



Perla



Cammello



Tortora

### Cannelé

Prodotto a mano con tecnica handloom.  
Trama in cotone, vello in lana himalayana  
e seta di bambù, bouclé in lana himalayana.  
Dimensioni mm: rettangolare 1700×2400  
2300×3000 - 3000×4000  
quadrato 3000×3000.

Handmade with the handloom technique.  
Cotton weave, fleece in Hymalayan wool  
and bamboo silk, Hymalayan wool bouclé.  
Dimensions in: rectangular 67"x94 1/2"  
90 1/2"x118" - 118"x157 1/2"  
square 118"x118".



### Tratto

Prodotto a mano con tecnica handloom.  
Trama in cotone, vello in lana himalayana  
e seta di bambù.  
Dimensioni mm: rettangolare 1700×2400  
2300×3000 - 3000×4000  
quadrato 3000×3000.

Handmade with the handloom technique.  
Cotton weave, fleece in Hymalayan wool  
and bamboo silk.  
Dimensions in: rectangular 67"x94 1/2"  
90 1/2"x118" - 118"x157 1/2"  
square 118"x118".

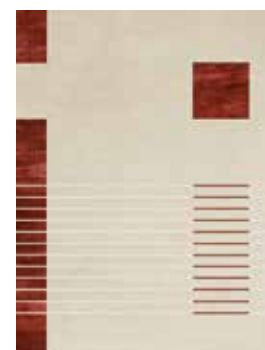

Ruggine



Carbone



Tortora

TAPPETI  
CARPETS

**Frame**

Prodotto a mano con tecnica handloom.  
Trama in cotone, vello in seta di bambù.  
Bordo perimetrale di 80 mm in lana  
himalayana in tinta solo per la versione  
rettangolare.  
Dimensioni mm: rettangolare 1700x2400  
2300x3000 - 3000x4000  
quadrato 3000x3000 - ovale 2300x4000.

Handmade with the handloom technique.  
Cotton weave, fleece in bamboo silk.  
80 mm - 3 1/4" perimeter edge in Himalayan  
wool in matching colour only for the  
rectangular version.  
Dimensions inches: rectangular 67"x94 1/2"  
90 1/2"x118" - 118"x157 1/2"  
square 118"x118" - oval 90 1/2"x157 1/2".



Grey



Gold



Perla



Carbone



**Plain**

Prodotto a mano con tecnica handloom.  
Trama in cotone, vello in aloe e seta di bambù.  
Nella versione rettangolare fascia di  
150 mm in tonalità più scura sul lato superiore  
e inferiore e di 100 mm per la dimensione  
1700x2400. Nella versione tonda la parte più  
scura è di 1/4 del tappeto.  
Dimensioni mm: rettangolare 1700x2400  
2300x3000 - 3000x4000  
quadrato 3000x3000 - rotondo Ø 2500.

Handmade with the handloom technique.  
Cotton weave, fleece in aloe and bamboo silk.  
Rectangular version 6" band in darker colour  
in the upper and lower side and 4" band for  
the size 67"x94 1/2".  
In the round version the darkest part is  
1/4 of the carpet.  
Dimensions inches: rectangular 67"x94 1/2"  
90 1/2"x118" - 118"x157 1/2"  
square 118"x118" - round Ø 94 1/2".



Tortora



Cipria

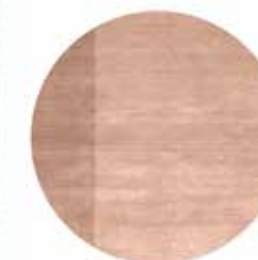

Ruggine



Arena



Natural



## TAPPETI CARPETS

### Dama

Prodotto a mano con tecnica handloom.  
Trama in cotone, vello in lana himalayana e seta di bambù.  
Dimensioni mm: rettangolare 1100×3500  
1700×2400 - 2300×3000 - 3000×4000  
quadrato 3000×3000.



Handmade with the handloom technique.  
Cotton weave, fleece in Hymalayan wool and bamboo silk.  
Dimensions inches: rectangular 43 1/4"x137 1/4" - 67"x94 1/2" - 90 1/2"x118" - 118"x157 1/2" square 118"x118".

### Stripes

Prodotto a mano con tecnica handloom.  
Trama in cotone, vello in lana himalayana e seta di bambù.  
Dimensioni mm: rettangolare 1100×3500  
1700×2400 - 2300×3000 - 3000×4000  
quadrato 3000×3000.



Handmade with the handloom technique.  
Cotton weave, fleece in Hymalayan wool and bamboo silk.  
Dimensions inches: rectangular 43 1/4"x137 1/4" - 67"x94 1/2" - 90 1/2"x118" - 118"x157 1/2" square 118"x118".

### Soft

Prodotto a mano con tecnica handloom.  
Trama in cotone, vello in seta di bambù grigio sfumato.  
Dimensioni mm: rettangolare 1700×2400  
2300×3000 - 3000×4000  
quadrato 3000×3000.



Handmade with the handloom technique.  
Cotton weave, fleece in bamboo silk shaded grey.  
Dimensions inches: rectangular 67"x94 1/2" - 90 1/2"x118" - 118"x157 1/2" square 118"x118".

FINITURE  
FINISHINGS

**Laccato opaco**  
**Mat lacquer**



82 glacier white



01 bianco

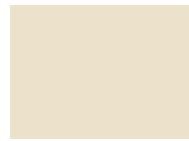

35 canapa



26 corda



88 castoro



46 tortora



64 arena



89 roccia



48 visone



49 moka



04 grafite



91 carbone

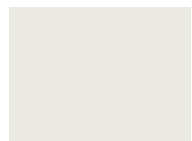

60 ghiaccio



09 pioggia



78 ferro



83 ocra



85 caramello



67 muschio



92 vischio



87 granata



86 danubio



70 prussia

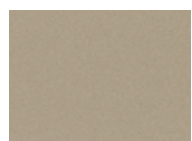

77 champagne



24 ottone

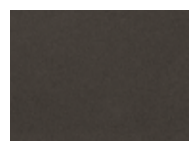

23 bronzo



90 piombo

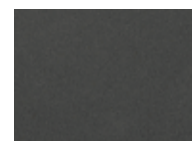

02 ardesia

**Laccato lucido**  
**Glossy lacquer**



82 glacier white



01 bianco

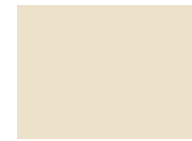

35 canapa



26 corda



46 tortora



60 ghiaccio



48 visone



49 moka



83 ocra



85 caramello



87 granata

**Laccato antigraffio**  
**Antiscratch lacquer**



01 bianco

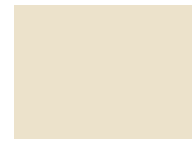

35 canapa



04 grafite



91 carbone

**Laccato metallico**  
**Metallic lacquer**



23 bronzo



24 ottone



25 titanio



FINITURE  
FINISHINGS

**Essenza  
Wood**



rovere gold  
gold oak



rovere spessart  
spessart oak



noce gold  
gold walnut



olmo nero  
black elm



massello noce canaletto  
solid walnut canaletto



cedro  
cedar



noce  
walnut

**Cuoio  
Hide**

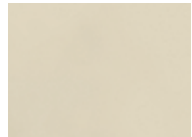

28 avorio

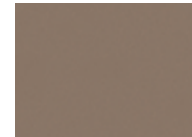

29 tortora

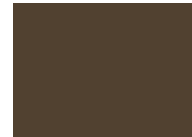

19 caffè



38 oliva

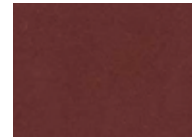

15 prugna



26 invecchiato



03 grigio scuro

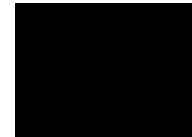

02 nero

**Tecnocover Grain  
Grain tecnocover**



05 latte



01 elefante



02 moro



06 nocciola

**Tessuto  
Fabric**



lino chiaro



lino écre



lino bruciato



lino scuro

**Marmo levigato  
Mat marble**



bianco carrara



calacatta oro



verde lepanto

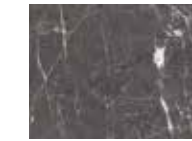

grigio stardust



emperador dark



sahara noir  
finitura poliestere  
polyester finish



zecevo

**Marmo lucido  
Glossy marble**



bianco carrara



calacatta oro



verde lepanto



grigio stardust

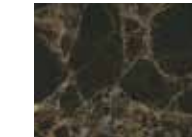

emperador dark



sahara noir  
finitura poliestere  
polyester finish



noir saint laurent

**Gabbro  
Gabbro**



nero assoluto  
texture juta

**Onice  
Onyx**



ambra  
amber

**Semiprezioso  
Semiprecious stone**



lapislazzulo blu  
blue lapis lazuli

**Pietra spatolata  
Spatula-finish stone**



ebano  
ebony

**Grès porcellanato lucido  
Glossy gres porcelain**



emperador dark



calacatta oro



sahara noir

FINITURE  
FINISHINGS

**Tessuti  
Fabrics**

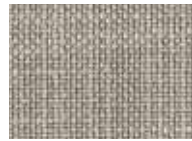

atlanta cat. b  
12 colori - colours



caleo cat. b  
15 colori - colours



chios cat. b  
13 colori - colours



eraclea cat. b  
12 colori - colours

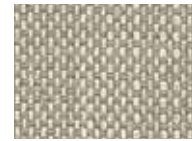

aspen cat. c  
12 colori - colours

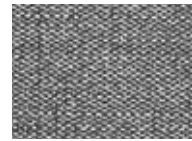

lima cat. c  
11 colori - colours



siviglia cat. c  
14 colori - colours



antea cat. d  
13 colori - colours



cordoba cat. d  
13 colori - colours



corinto cat. d  
5 colori - colours



indra cat. d  
12 colori - colours



itaca cat. d  
10 colori - colours



kushiro cat. d  
13 colori - colours



lipsi cat. d  
11 colori - colours



micene cat. d  
9 colori - colours



milos cat. d  
5 colori - colours

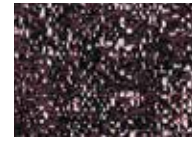

olimpia cat. d  
14 colori - colours



oxford cat. d  
8 colori - colours



rabat cat. d  
10 colori - colours

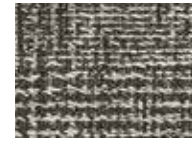

sendai cat. d  
5 colori - colours



sparta cat. d  
12 colori - colours



agadir cat. e  
9 colori - colours



arcadia cat. e  
12 colori - colours



argo cat. e  
13 colori - colours



hannover cat. e  
11 colori - colours



kitami cat. e  
12 colori - colours



naxos cat. e  
11 colori - colours



nayoro cat. e  
10 colori - colours



orleans cat. e  
10 colori - colours



persia cat. e  
16 colori - colours



skyros cat. e  
12 colori - colours



zante cat. e  
11 colori - colours



brest cat. g  
10 colori - colours



dundee cat. g  
6 colori - colours



glasgow cat. g  
6 colori - colours



lero cat. g  
2 colori - colours



nancy cat. g  
6 colori - colours



norwich cat. g  
8 colori - colours



sheffield cat. g  
9 colori - colours



siro cat. g  
4 colori - colours



tebe cat. g  
11 colori - colours



gibson cat. z  
6 colori - colours

**Pelle  
Leather**



spring cat. p  
13 colori - colours



colors cat. s  
25 colori - colours



silk cat. s  
13 colori - colours



silk intrecciata cat. s  
woven leather silk  
13 colori - colours



deep cat. x  
10 colori - colours



special cat. x  
21 colori - colours



nabuk cat. y  
10 colori - colours



nabuk intrecciata cat. y  
woven leather nabuk  
10 colori - colours



invecchiata cat. y  
6 colori - colours



soft cat. y  
14 colori - colours

**Pelliccia Cashmere  
Cashmere fur**



bianco



grigio



nero



bianco/nero



cappuccino



nero

**Pelle Hairy  
Hairy leather**

**Tecnocover Pixel  
Pixel tecnocover**

**Bordura gros-grain - bordura in seta - filati  
Grosgrain border - silk border - yarns**



burro



perla



sahara



rubino



tempesta  
escluso bordura in seta  
except silk border



navy



acciaio



nero

**Provence coordinati letto  
Bed linen Provence**



01 bianco



02 panna



08 polvere



04 tortora



06 roccia



07 grafite



03 ghiaccio

FINITURE  
FINISHINGS

**Vetro  
Glass**

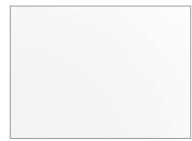

1000 trasparente  
transparent

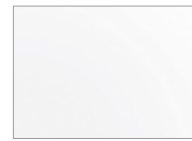

2000 trasparente  
extrachiaro-transparent  
extralight



3051 bronzato  
bronzed



3050 fumé



2700 line

**Vetro riflettente  
Reflecting glass**

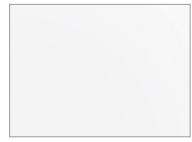

5000 trasparente  
transparent



5010 blu



5051 bronzato  
bronzed



5059 fumé

**Vetro acidato  
Etched glass**



5380 acciaio



5323 bronzo



5325 titanio

**Specchio  
Mirror**



4000 bianco  
white



4051 bronzato  
bronzed

**Vetro satinato  
Mat glass**



2301 bianco extrachiaro  
extralight bianco

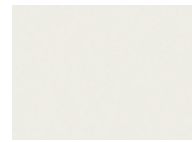

2373 ghiaccio  
ghiaccio

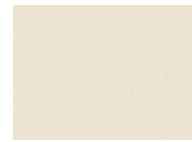

1335 canapa



1364 arena



1304 grafite



1303 nero

**Vetro lucido  
Glossy glass**

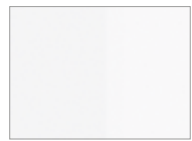

2201 bianco extrachiaro  
extralight bianco



2273 ghiaccio



1235 canapa



1264 arena



1204 grafite



1203 nero



1259 bordeaux

**Nobilitato  
Melamine**



olmo  
elm



noce c.  
walnut c.



rovere cenere  
cenere oak



rovere spessart  
spessart oak



canvas beige



canvas grigio



graffiti 01 bianco



graffiti 35 canapa



graffiti 60 ghiaccio



silk canapa



silk grey



silk bronzo



club 01 bianco



skin  
27 colori laccato opaco  
27 mat lacquered colours



skin 94 latte  
laccato opaco  
mat lacquered



skin 97 elefante  
laccato opaco  
mat lacquered



skin 93 moro  
laccato opaco  
mat lacquered



skin 98 nocciola  
laccato opaco  
mat lacquered

**Nobilitato interno cassetti  
Melamine drawers structure**



ardesia



madras  
Quid sistema giorno -  
day system



roller latte



roller ardesia

**Metacrilato  
Methacrylate**

**Parti metalliche  
Metal parts**



brown nickel opaco  
mat brown nickel



brown nickel lucido  
glossy brown nickel



brown nickel satinato  
brushed brown nickel



champagne opaco  
mat champagne



champagne satinato  
brushed champagne



ardesia opaco  
mat ardesia



cromo satinato  
brushed chrome



cromo nero  
black chrome



cromo nero satinato  
brushed black chrome

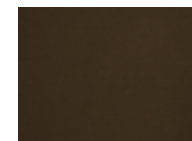

bronzato  
bronzed



bronzo anticato  
antique bronze

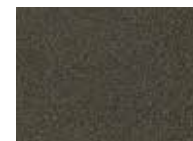

brunito opaco  
mat brunito



spatolato ferro  
spatula-finish ferro



spatolato bronzo  
spatula-finish bronzo



oro lucido  
glossy gold



alluminio brill  
aluminium brill

DIVANI  
SOFAS



Saint-Germain, design Jean-Marie Massaud  
pp. 10-53



Bristol, design Jean-Marie Massaud  
pp. 54-99



Mondrian, design Jean-Marie Massaud  
pp. 100-145



Westside, design Jean-Marie Massaud  
pp. 146-179



Bellport, design Jean-Marie Massaud  
pp. 180-213



Dune, design Carlo Colombo  
pp. 214-235



Sydney, design Jean-Marie Massaud  
pp. 236-249



Shangai, design Carlo Colombo  
pp. 250-263



Paris Seoul, design Jean-Marie Massaud  
pp. 264-277

POLTRONE  
ARMCHAIRS



Le Club, design Jean-Marie Massaud  
pp. 282-295



Kay Lounge, design Jean-Marie Massaud  
pp. 296-313



Mad Chair, design Marcel Wanders studio  
pp. 317-329, 352



Mad Joker, design Marcel Wanders studio  
pp. 330-335, 353



Mad Queen, design Marcel Wanders studio  
pp. 336-343, 354



Mad King, design Marcel Wanders studio  
pp. 344-345, 348-351, 355



Mad Chaise Longue, design Marcel Wanders studio  
pp. 346-347, 354



Stanford, design Jean-Marie Massaud  
pp. 359-367, 374



Stanford Lounge, design J.M. Massaud  
pp. 368-373, 375

POLTRONE  
ARMCHAIRS



Gentleman Relax, design Marcel Wanders studio  
pp. 379-383, 386-389, 398



Gentleman's Friends, design Marcel Wanders studio  
pp. 380-381, 384-385, 399



Gentleman Reserved, design Marcel Wanders studio  
pp. 390-393, 399



Gentleman Single, design Marcel Wanders studio  
pp. 394-397, 398



Jane, design Emmanuel Gallina  
pp. 403-407, 410-411, 426



Jane, design Emmanuel Gallina  
pp. 404-405, 408-409, 426



Jane Large, design Emmanuel Gallina  
pp. 412-417, 425, 427



Jane Lounge, design Emmanuel Gallina  
pp. 418-423, 427



Santa Monica, design Jean-Marie Massaud  
pp. 431-435, 448



Santa Monica Lounge, design J.M. Massaud  
pp. 436-441, 449



Santa Monica Home, design J.M. Massaud  
pp. 442-447, 448



Ipanema, design Jean-Marie Massaud  
pp. 450-459



Gaston, design Vincent Van Duysen  
pp. 460-467



Marlon, design Vincent Van Duysen  
pp. 472-475, 478, 479



Marlon Lounge, design Vincent Van Duysen  
pp. 471, 476-477, 479



Ventura Lounge, design J.M. Massaud  
pp. 480-489



Wallace, design Jean-Marie Massaud  
pp. 490-497

**Poliform Spa**  
via Montesanto 28  
Casella postale n. 1  
22044 Inverigo (CO) Italy  
t +39 031 6951  
f +39 031 699444  
info@poliform.it  
poliform.it



2018 Adi Compasso D'oro  
Career Award

**Poliform realizza tutte le sue collezioni in Italia usando componenti e materie prime selezionate.**

**All the Poliform collections are manufactured 100% in Italy using top-class components and materials.**

Poliform si riserva il diritto di apportare, senza preavviso, ogni modifica mirata al miglioramento funzionale e qualitativo dei propri prodotti. Testi e disegni presenti in questo stampato hanno scopo divulgativo: per ogni aspetto tecnico e dimensionale fare riferimento ai listini aziendali e relativi aggiornamenti. I campioni di colori e materiali hanno valore indicativo.

Poliform reserves the rights at all time to apply modifications for the functional or qualitative improvement of its products. Texts and drawings present in this brochure have a divulgative purpose: for every technical and dimensional aspect please refer to the company's price lists and their relative updatings. The colour and material samples have an indicative value.

**Creative Direction**  
Apartamento Studios

**Graphic Design**  
Apartamento Studios

**Interiors Photography**  
Federico Cedrone, Omar Sartor

**Still Life Photography**  
Silvia Orlandi

**Interiors Styling**  
Poliform Lab

1st edition January 2022  
cod. 124/R1/2022





POLIFORM.COM